



Cytek[®] Northern Lights[™] (NL)-CLC User's Guide



Copyrights

© 2020-2022, Cytek Biosciences Inc. All rights reserved. No part of this publication may be reproduced, transmitted, transcribed, stored in retrieval systems, or translated into any language or computer language, in any form or by any means: electronic, mechanical, magnetic, optical, chemical, manual, or otherwise, without prior written permission from Cytek Biosciences.

The information in this guide is subject to change without notice. Cytek Biosciences reserves the right to change its products and services at any time to incorporate the latest technological developments. Although this guide has been prepared with every precaution to ensure accuracy, Cytek Biosciences assumes no liability for any errors or omissions, nor for any damages resulting from the application or use of this information. Cytek Biosciences welcomes customer input on corrections and suggestions for improvement.

Trademarks

Cytek, Cytek, the Cytek logo, SpectroFlo, Northern Lights, "Complexity" and "Similarity" are trademarks or registered trademarks of Cytek Biosciences, Inc. All other service marks, trademarks and tradenames appearing in this user guide are the property of their respective owners.

FCC Information

WARNING: Changes or modifications to this unit not expressly approved by the party responsible for compliance could void the user's authority to operate the equipment.

NOTICE: This equipment has been tested and found to comply with the limits for a Class A digital device, pursuant to Part 15 of the FCC Rules. These limits are designed to provide reasonable protection against harmful interference when the equipment is operated in a commercial environment. This equipment generates, uses, and can radiate radio frequency energy and, if not installed and used in accordance with the instruction manual, can cause harmful interference to radio communications. Operation of this equipment in a residential area is likely to cause harmful interference in which case the user will be required to correct the interference at his or her own expense.

Shielded cables must be used with this unit to ensure compliance with the Class A FCC limits.

This Class A digital apparatus meets all requirements of the Canadian Interference-Causing Equipment Regulations.

Cet appareil numérique de la classe A respecte toutes les exigences du Règlement sur le matériel brouilleur du Canada.

CDRH Information

Class I laser product.

Regulatory Information

Class 1 Laser Product

IVD  For In Vitro Diagnostic Use

Authorized Representative in the European Community

EC **REP**

Emergo Europe
Prinsessegracht 20
2514 AP The Hague
Netherlands

History

Revision	Date	Change
N9-20039US Rev. A	7/2020	Initial release
N9-20039US Rev. B	1/2021	Added information on new loader
N9-20039US Rev. C	9/2021	Minor corrections per reviewers
N9-20039US Rev. D	1/2022	Corrected addresses and added manufacture symbol. Updated Replacement part numbers table to align with current released parts and assemblies.

Contents

Chapter 1: Introduction	7
Intended Use	7
About this Guide	7
Safety	7
Safety Symbols	7
General Safety	8
Electrical Safety	9
Biological Safety	9
Laser Safety	9
Technical Support	10
Chapter 2: Overview	11
Cytometer Overview	12
Fluidics System	13
Optics	15
Software Overview	17
Get Started Menu	17
About Experiments	18
About Worksheets	21
About Reports	23
Chapter 3: Startup & Shutdown	25
Filling the Sheath and Emptying the Waste	25
Filling the Sheath	25
Emptying the Waste	26
Starting Up the System	27
Shutting Down the System	28
Chapter 4: QC & Setup	29
Daily QC	29
Performing Daily QC	29
QC Report	32
Reference Controls	34
Running Reference Controls	34
Updating Reference Controls	39
Levey-Jennings Tracking	40
Gain Settings	41
Alarm Ranges	41

Chapter 5: Acquisition	43
Raw vs Unmixed Data	43
Unmixing and Compensation	43
Setting Up an Experiment	44
Acquisition Experiment Overview	44
Experiment Display	44
Creating a Default Experiment	53
Creating a New Experiment	54
Creating an Assay	60
Create New Assays	60
Chapter 6: Library, Preferences, and Users	63
Library	63
QC Beads	63
Fluorescent Tags	63
Labels	64
Keywords	65
Spillovers	67
User Settings	67
Loader Settings	68
Worksheet Templates	68
Experiment Templates	69
Backup & Restore	69
Preferences	71
Acquisition Preferences	71
Worksheet Preferences	73
Plot Preferences	74
Gates Preferences	75
Statistics Preferences	76
Fonts Preferences	77
Notifications Preferences	78
Storage Preferences	78
QC Setup Preferences	80
Cytometer Preferences	80
Users	82
Managing Users	82
Use Time	84
User Role	84
User Policy	87
Chapter 7: Unmixing and Compensation	89
Spectral Unmixing	89
Understanding Full Spectrum Flow Cytometry	89
Unmixing Workflows	90

Unmixing Overview	90
Live Unmixing	92
Post-Acquisition Unmixing	97
Virtual Filters	102
Chapter 8: Worklist	107
Create or open a worklist	107
Add tasks	108
Reference controls	109
Unmix	110
Lot specific reference controls	111
Arrange sample locations in a carrier	112
Data collection	112
Export Report	113
Chapter 9: Loader	119
Loader Overview	119
Automated Sample Loader Components	120
Loader Acquisition Controls and Settings	122
Loader Daily Workflow	123
Startup	123
Set Up Experiment	124
Acquisition	124
Loader Shutdown	129
Chapter 10: Maintenance	131
Maintenance Schedule	131
Scheduled Maintenance	131
Unscheduled Maintenance	131
SIT Flush	132
Purge Filter	132
Clean Flow Cell	133
Long Clean	133
Fluidics Shutdown	134
Cleaning the External Surfaces	135
Inspecting the Fluidics Lines	135
Replacing the Sheath Filter	135
Replacing the SIT	136
Loader Maintenance	139
Calibrating the Loader Stage and Plate	139
Cleaning the External Surfaces of the Loader	140
Loader Connections	141
Uninstalling the Loader Power supply	141
Loader Lifting and Carrying Instructions	141

Chapter 11: Troubleshooting	143
General Troubleshooting	144
Loader Troubleshooting	146
Chapter 12: Glossary	147
Chapter 13: Specifications	151
Cytometer	151
Optics	151
Fluidics	152
Performance	152
Workstation	154
Loader Technical Specifications	154
Installation Requirements	154
Chapter 14: Supplies and Replacement Parts	157
Index	159

Introduction

Intended Use

The Cytex Northern Lights (NL)-CLC flow cytometer system is intended for use as an in vitro diagnostic device only in countries where the regulatory approval has been obtained from the local regulatory authorities. It is intended for use in flow cytometric applications.





About this Guide

This guide provides information on the NL-CLC flow cytometer, daily workflow, SpectroFlo® software features, instrument maintenance, and cytometer specifications. It also includes troubleshooting tips and service information.

Safety

Safety Symbols

The following table lists symbols used throughout this guide.

Symbol	Meaning
	Caution: hazard or unsafe practice that could result in material damage, data loss, minor or severe injury, or death
	Risk of electric shock
	Biological risk
	Laser radiation

General Safety

- Read all safety instructions completely before using the equipment. Keep the instructions in a safe place.
- Follow all instructions when operating the instrument.
- If the equipment is used in a manner not specified by the manufacturer, the protection provided by the equipment may be impaired.
- Do not place any object on top of the instrument.
- Do not block any ventilation openings.
- Do not place the unit near any heat sources such as radiators, heat registers, stoves, or other devices (including amplifiers) that produce heat.
- Use only attachments/accessories specified by the manufacturer.
- Use only with the cart, stand, tripod, bracket, or table specified by the manufacturer or sold with the equipment. When a cart is used, use caution when moving the cart/equipment combination to avoid injury from tipping over.
- Unplug the instrument when it will not be used for long periods of time.
- Refer all servicing to qualified service personnel. Service is required when the unit has been damaged in any way, such as: if the power-supply cord or plug is damaged, if the unit is dropped, if liquid is spilled onto the unit or objects fall into the unit, if the unit is exposed to rain or moisture, or if the unit does not operate properly.
- Do not expose the instrument to temperatures outside the range of 15°C to 28°C.
- Concentrations of sodium hypochlorite (bleach) higher than 10%, as well as other cleaning agents, can damage the instrument. Use a 10% solution of household bleach to clean, where indicated. A 10% bleach solution is prepared by adding 1 part household bleach to 9 parts deionized water.
 - **NOTE:** Household bleach contains 5–7% sodium hypochlorite.
- Before turning on the cytometer, visually inspect all containers. Wear standard PPE laboratory attire such as protective gloves, eyewear, and lab coat.
- Purge the sheath filter if air bubbles are visible in the sheath filter, or if the plenum or sheath container have run dry.
- Fill the sheath container as needed. Never use tap water as sheath solution. Never use surfactant-based sheath solutions.
- Do not run bleach or detergent through the sheath filter. It is difficult to remove cleaning solutions from the sheath filter.
- Check the cytometer periodically for fluid leaks or crimped lines. If evidence of a leak is detected, contact Cytex Technical Support immediately. Do not attempt to repair the instrument.
- When performing Daily QC, always select the current bead lot number.

Electrical Safety

- Do not place liquids on top of the instrument. Any spill into the ventilation openings could cause electrical shock or damage to the instrument.
- Do not use this equipment near water.



WARNING: To reduce the risk of fire or electric shock, do not expose this apparatus to rain or moisture.

- Use only the power supply cord specified by the manufacturer. The power cord of the unit is equipped with a 10A three-prong power plug. Do not remove the ground pin of the power plug under any circumstances. Make sure the plug is securely plugged into the power outlet to prevent fire. If the power supply cord needs to be replaced, the cross section area of the conductor should be at least 16 AWG. This is to prevent electric fire or shock.
- Use only the fuse specified by the manufacturer. The fuse is 250 VAC, 5 A, size 5 x 20 mm.
- Protect the power cord from being tread upon or pinched, particularly at the plug and the point where it emerges from the equipment. Be sure that the power outlet is located near the equipment so that it is easily accessible.

Biological Safety

- Empty the waste container when filling the sheath container or as needed to prevent leakage. Take care to avoid damaging the fluid level sensor in the waste tank.
- Biological samples are potentially dangerous and/or life threatening. Adhere to proper handling procedures for samples and reagents. Wear standard PPE laboratory attire such as protective gloves, eyewear, and lab coat.
- Any instrument surface in contact with biological specimens can transmit potentially fatal disease. Use universal precautions when cleaning the instrument or replacing parts.

Laser Safety

The NL-CLC cytometer is a Class 1 Laser Product and complies with the US FDA Center for Devices and Radiological Health 21 CFR 1040.10 and 1040.11 except for deviations pursuant to Laser Notice No. 50, dated June 24, 2007. No laser radiation is accessible to the user during normal instrument operation.

The lasers are fully contained within the instrument and do not require any special work area safety except when service procedures are being performed. These procedures are performed only by Cytex service personnel.



CAUTION: Modification or removal of the optics covers or laser shielding could result in exposure to hazardous laser radiation. To prevent damage to skin and eyes, do not remove the optics covers or laser shielding, or attempt to service the instrument where laser warning labels are attached.

Use of controls or adjustments or performance of procedures other than those specified in this user's guide may result in hazardous radiation exposure.

To prevent exposure to laser radiation:

- Do not defeat any safety interlocks on the instrument.
- Do not use controls, make adjustments, or perform procedures other than those specified in this user's guide.
- Do not attempt to perform service procedures on the lasers.

Technical Support

For instrument support within the US, call 1-877-922-9835 (option 1).

Outside the US, call 1-510-657-0102. In Europe, call +31207653440.

Email Cytek at technicalsupport@cytekbio.com.

Visit our website, www.cytekbio.com, for up-to-date contact information.

When contacting Cytek, have the following information available:

- Serial number
- Any error messages
- Details or screen shots of recent system performance
- SpectroFlo software version and system firmware version, located in the Help module

Overview

Northern Lights System

The Northern Lights system consists of the NL-CLC flow cytometer and a computer workstation running SpectroFlo[®] CLC software for acquisition and analysis. SpectroFlo[®] QC beads are also included.

The cytometer is an air-cooled, compact benchtop instrument. It is equipped with up to three lasers, 38 detection channels for fluorescence, and three channels for scatter (blue laser FSC, blue laser SSC, and violet laser SSC). Sheath and waste fluids are contained in either 4-L tanks, included with the system, or 20-L cubitainers. Software indicators notify you when the sheath is getting low or the waste is getting full. The fluidics system includes a plenum for storing sheath, allowing you to fill the sheath tank during operation.

Optional high-throughput sample Loaders are available to automate sample delivery and acquisition. The loaders are compatible with 96-well plates. The new Automated Sample Loader (ASL) offers added compatibility for 96-well deep-well plates and 40-tube racks. See “Loader” on page 119 for more information.

The workstation is a dedicated USB-compatible PC with monitor, keyboard, and mouse. It runs Microsoft[®] Windows[®] 10 Pro with a 64-bit operating system, which is required for SpectroFlo software.



Cytometer Overview

Solid-state lasers transmit light through a flow cell where particles in suspension are focused, single file for interrogation by the laser. Proprietary, high-sensitivity, semiconductor detector APD arrays are equipped with up to 16 channels per laser to capture the emission spectra of dyes that emit in the 365 to 829-nm wavelength range. The resulting fluorescence and scatter signals are then collected and converted into electronic signals. On-board electronics convert these signals into digital data that can be acquired and recorded on the workstation.

The cytometer power button is located on the left side panel in the upper right area. When the cytometer is powered on, the power button is illuminated.

The front panel opens on hinges to the left to reveal the fluidics system. The SIT door to the right of the front panel opens to reveal the sample injection tube (SIT) assembly. The top cover opens to reveal the optics plate.

Front of Cytometer

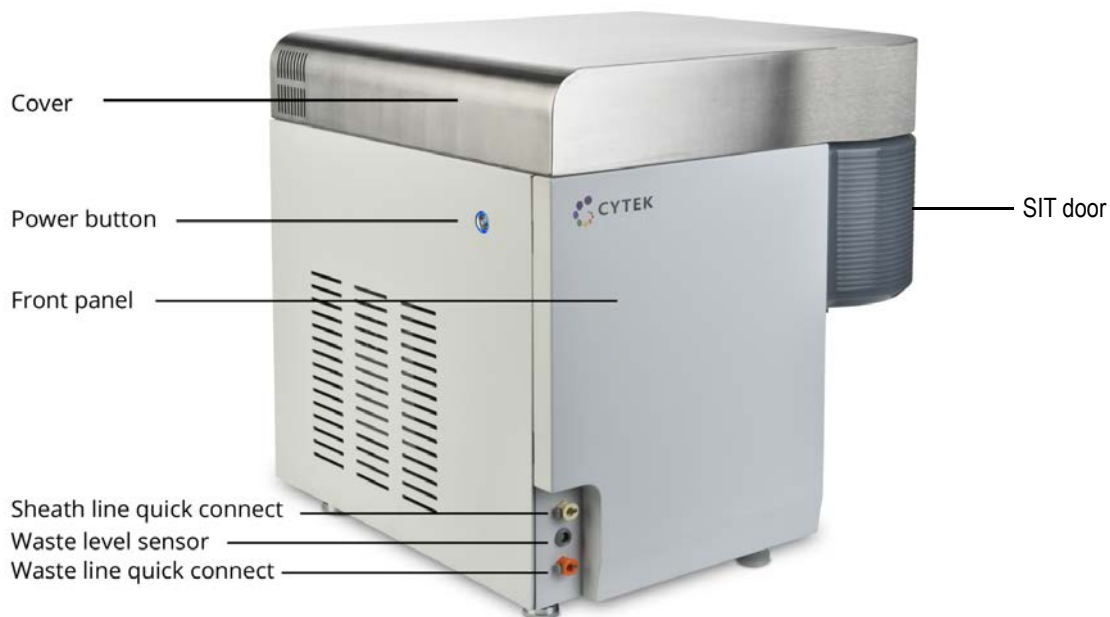

Do not place any object on top of the instrument.



Do not place liquids on top of the instrument. Fluid leaking into the cytometer could cause electrical shock or damage to the instrument.

Back of Cytometer

Allow 20.0 cm (8 in) between the back of the cytometer and the wall for proper ventilation without an air duct. Allow 10.0 cm (4 in) with an air duct.

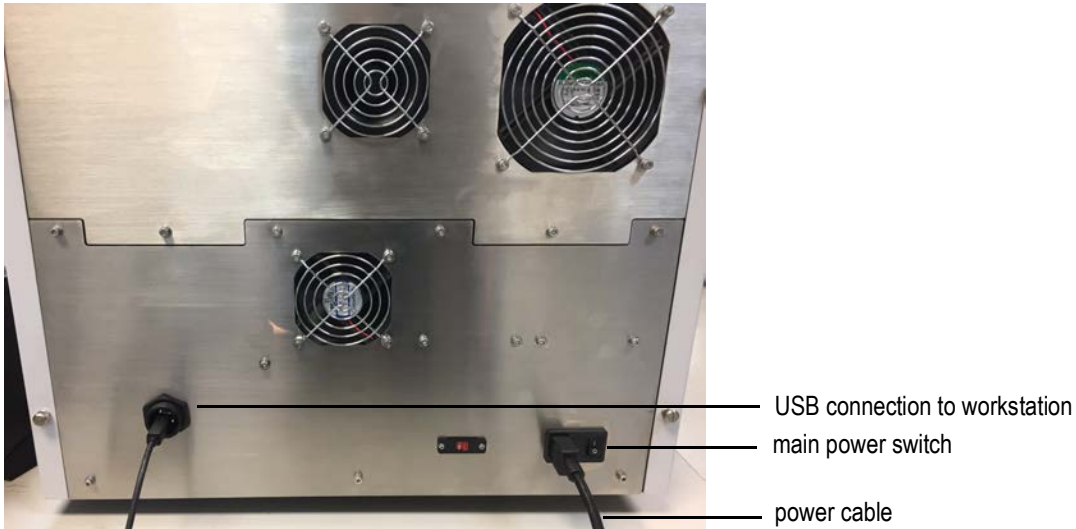

Fluidics System

Sample Injection Port and Sample Injection Tube

Sample, contained in a standard 12 x 75-mm tube, enters the cytometer through the sample injection tube (SIT) that is contained within the sample injection port (SIP). The 12 x 75-mm sample tube snaps into place under the SIP requiring no additional tube retention support. The SIT extends from the SIP during acquisition and retracts when the cytometer is not acquiring.

When using the optional Loader, a 96-well plate, 96-well deep-well plate, or 40-tube rack can be used for sample delivery in place of individual 12 x 75-mm sample tubes. See the “Loader” on page 119 for more information.

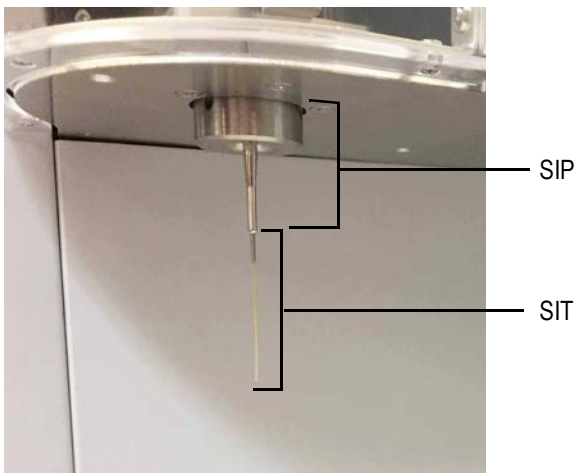

Fluid Containers

The cytometer draws sheath solution directly from a 20-L sheath cubitainer or the 4-L sheath tank provided by Cytek. It expels waste into an empty 20-L cubitainer or the 4-L waste tank provided by Cytek.

The included fluidics tanks are contained in a holding reservoir located on the left side of the cytometer. The 4-L tank with the transparent fluidic line is for sheath solution. The 4-L tank with the orange fluidic line is for waste.



Fluid Flow

The fluidics are driven by vacuum. An accumulator vessel is the source of vacuum for the system. Sheath solution is drawn into and stored in the sheath plenum before passing through a sheath filter, where debris and contaminants are removed. Before reaching the flow cell, the sheath stream passes through a degasser, which removes air bubbles. After passing the laser interrogation point, the combination of sheath solution and sample travels to the waste container.

Sheath and waste fluid levels are monitored by sensors. The waste level sensor is located underneath the waste tank cap. The sheath level sensor is located underneath the sheath plenum cap. Both sensors are monitored by the software.

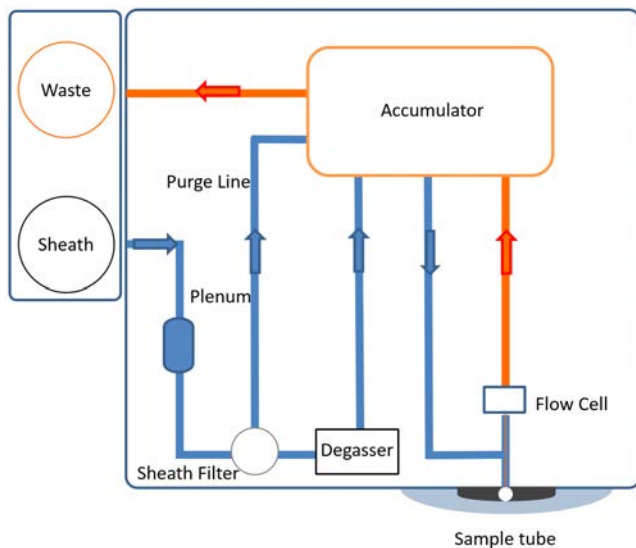

Fluidics Components

The following figure shows the fluidics components.

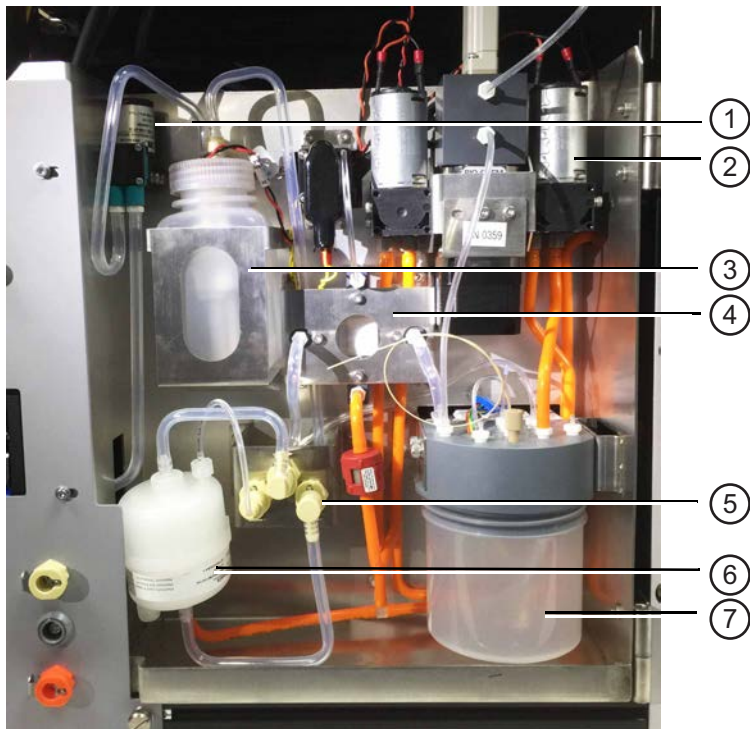

The following table describes the fluidics components.

No.	Component	Description
1	Plenum pump	Pulls sheath from the sheath tank to fill the plenum
2	Vacuum pump	Maintains the vacuum in the accumulator
3	Plenum	Storage vessel for sheath fluid before it flows to the sheath filter
4	Degasser	Removes air bubbles from the sheath fluid
5	Sheath filter quick connects (x3)	Sheath filter fluid input, fluid output, and vent line quick-connects
6	Sheath filter	Filters debris and particles from the sheath fluid
7	Accumulator	Vacuum source for the fluidics system

Optics

Unlike conventional flow cytometers that direct specific bandwidths of fluorescence light into discrete detectors or photomultiplier tubes (PMTs), the Northern Lights uses a solid-state, multi-channel, narrow-beam detector array for each laser. Each array can be configured with up to 16 detectors that are used to capture a part of the emission spectrum from each particle passing through the laser beam. The detector channels from up to three lasers are used to capture the entire emission spectra from each fluorescent-labeled particle. Spectral deconvolution (unmixing) algorithms calculate the contribution of the known individual fluorophore's spectra to the total collected signal.

For excitation, a proprietary flat-top laser design enables a constant power distribution across the width of the sample core stream.

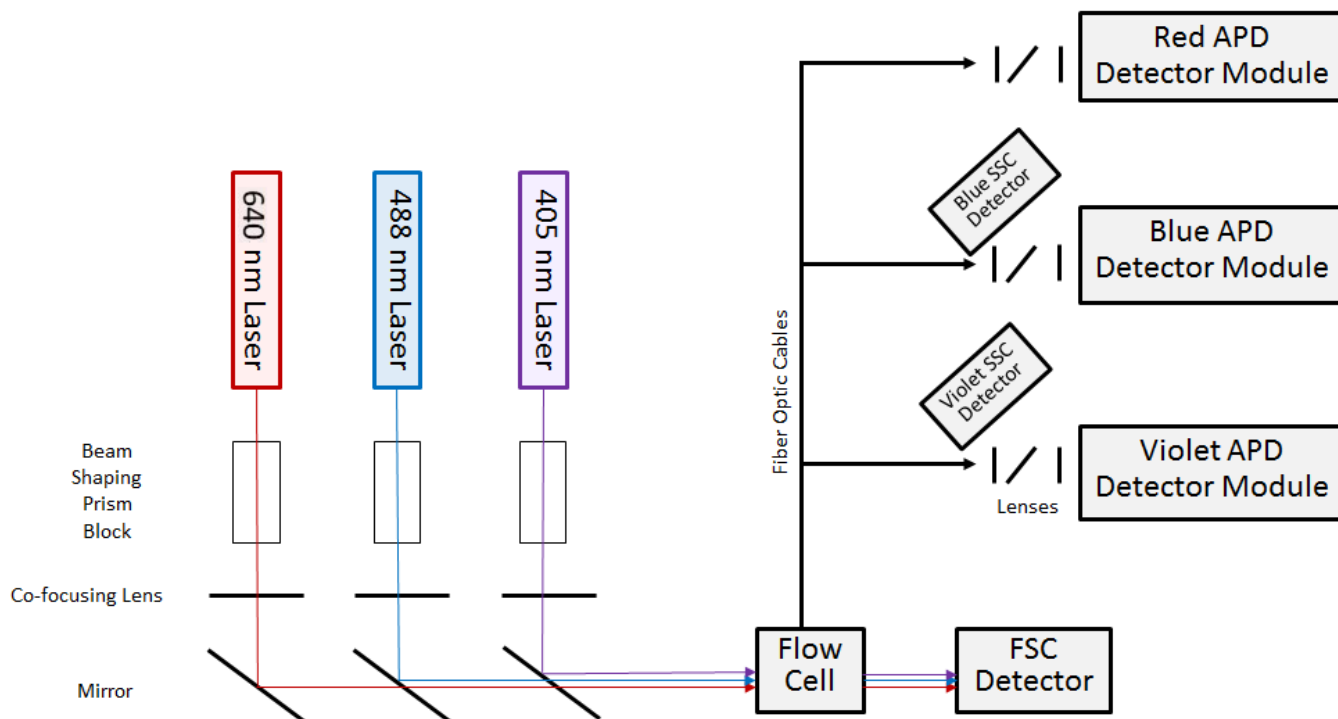

Optical configurations are as follows:

Laser	Excitation	Channels for detection	Detector names
Violet	405 nm	16	V1-V16
Blue	488 nm	14	B1-B14
Red	640 nm	8	R1-R8

The wavelengths detected by each detector (channel) increase across the array. See the table on [page 104](#) for details.

Software Overview

SpectroFlo® CLC software allows you to acquire and analyze samples and adjust instrument settings. Once you log into the software, a Get started menu appears.

Get Started Menu

The Get started menu provides seven modules that allow you to perform various functions. These same seven modules are also accessible across the upper-right corner of each module screen.

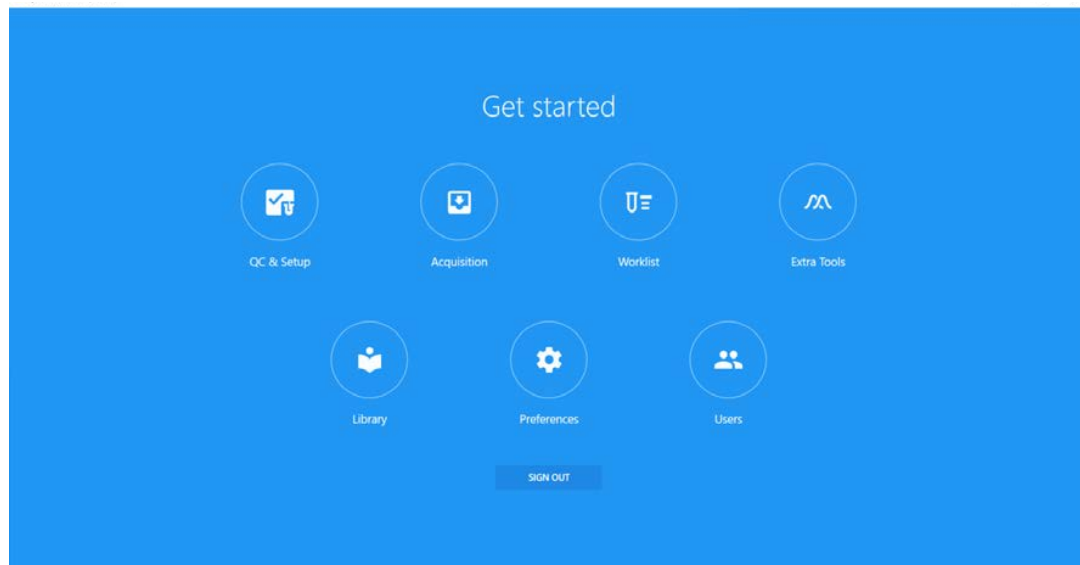

The following table describes options in the Get started menu.

Module	Description
QC & Setup	Daily QC ensures that the instrument is in optimal condition for use. Run SpectroFlo QC Beads daily to assess system performance and to adjust settings to account for day-to-day variation. Levey-Jennings reports keep track of trends in system performance. Setup allows you to create reference controls. See “QC & Setup” on page 29 for information.
Acquisition	The Acquisition module allows you to create experiments to acquire and analyze data. Experiments can be created through a guided wizard or created from previously saved templates. See “Acquisition” on page 43 for information.
Worklist module	The worklist is used for batch sample data collection and report generation of assay(s). See “Worklist” on page 107 for information.
Extra Tools	Here, FCS files can either be unmixed or compensated using virtual filters. See “Unmixing and Compensation” on page 89 for information.
Library	The library allows you to store experiment templates, worksheet templates, user settings, fluorescent tags, SpectroFlo QC bead information, label information, and keywords. See “Library” on page 63 for information.
Preferences	Software preferences can be changed to customize the software. Default plot sizes, fonts, gate colors, print layouts, statistics box table option, and more can all be changed in the Preferences. See “Preferences” on page 71 for information.

Module	Description
Users	The Users module contains user management options and administrative controls. See “Users” on page 82 for information.

About Experiments

The Acquisition module provides the tools necessary to acquire data, such as the acquisition controls used to start, stop, and record data, and the instrument controls used to set the threshold and adjust the detector gains. See [“Experiment Display” on page 44](#) for more information on these controls. Experiments contain the fluorescent tags and labels used in the experiment, the stopping criteria, and the groups of tubes run, which can include the reference control group. You can create groups for your samples, if you wish, to conveniently organize samples by type or staining panels, for example.

Opening an Experiment

When you click Acquisition from the Get started menu, the Acquisition Experiment menu (below) is displayed, allowing you to open a default or template experiment, create a new experiment, or import an experiment. A wizard walks you through the steps to create a new experiment.

■ **NOTE:** By default the Acquisition menu in the left pane is collapsed, showing only the icons for Experiment, Worksheet, Cytometer. To expand the menu to show the labels, click the arrows (>>) at the bottom of the pane.

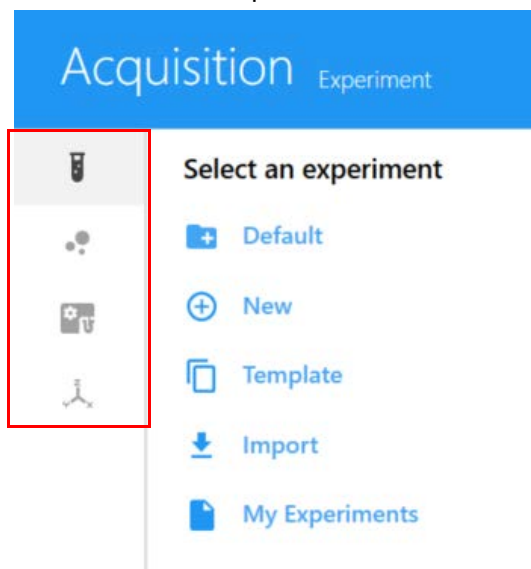

Experiments can be created using several different methods. The following table describes the options in the Acquisition Experiment menu:

Method	Description
Default	Opens a new experiment with one group containing one tube and a set of labels and fluorescent tags in a default experiment worksheet template. The default experiment is user configurable. It is the quickest way to begin sample acquisition.
New	Opens the New Experiment Wizard to guide you through creating an experiment.

Method	Description
Template	Allows you to select from a list of saved experiment and assay templates (see page 19).
Import	Imports an experiment ZIP file that was exported.
My Experiments	Allows you to select from a list of saved experiments. NOTE: Original experiments can be duplicated without data, which is equivalent to opening an experiment template. Right-click an experiment in My Experiments and select Duplicate (with or without data).

Completed experiments can be accessed through the My Experiments option in the Acquisition Experiment menu. Use the column headers to sort the list of experiments. For every tube recorded, two FCS files are saved, one raw and one unmixed. Use My Experiments to open experiments you already ran, as you may want to review the data or acquire more samples. You can also export experiments from My Experiments (below). A ZIP file is exported, containing all the raw data files, if applicable (and unmixed files for unmixed experiments), as well as the worksheet templates and experiment template.

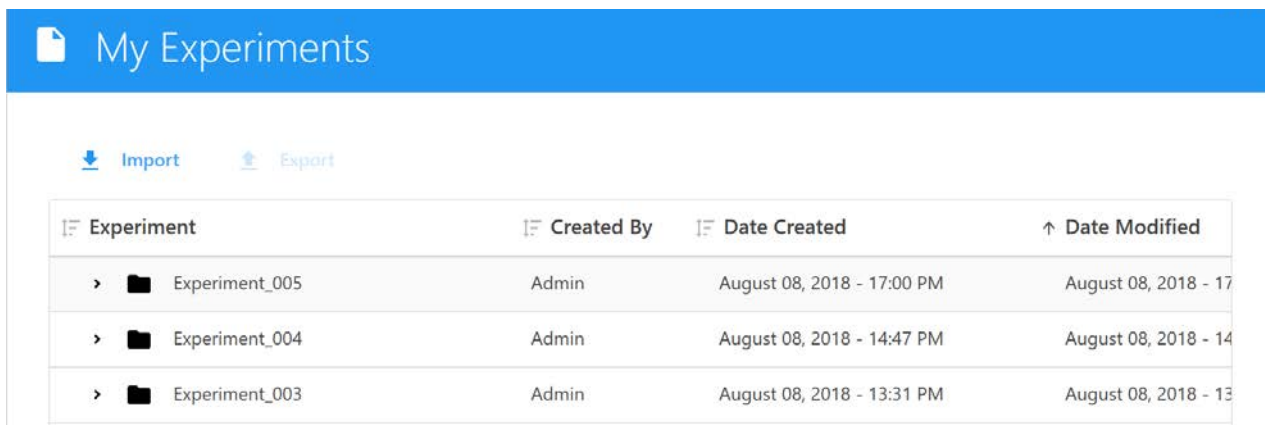

FCS Files

FCS files generated from an experiment are stored in the Export folder by default, or the folder you set as the default. See ["Storage Preferences" on page 78](#) for information. Experiments can contain the following types of FCS data files for each tube run:

- raw data files only (for samples that were acquired in an experiment)
- raw data files + unmixed data files (for samples that were acquired and unmixed live during acquisition)
- unmixed data files only (for samples that were unmixed post acquisition)

Experiment Templates

Use the Save As option above the experiment's tube/group (hierarchy) list to save the current experiment as a template, which can then be used for running similar experiments. Experiment templates include fluorescent tags used in the experiment, reference controls, groups/tubes, labels, worksheets, and stopping criteria. Templates are saved in the library. To open and use a

template, select **Template** from the Acquisition Experiment menu. See “[Experiment Templates](#)” on page 69 for more information on experiment templates.

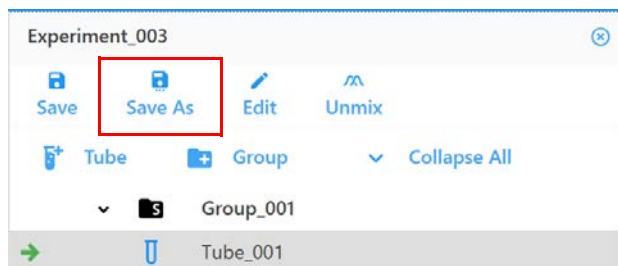

About Worksheets

Worksheets are used to visualize the data in the experiment. Each experiment requires at least one worksheet. A worksheet allows you to view the data in plots during acquisition, as well as perform analysis functions. Worksheets contain the tools necessary to create plots, gates, annotations, statistics, and the population hierarchy. Worksheets are saved with the experiment and can be saved separately and reused across experiments.

Two types of worksheets are available—worksheets for raw data and worksheets for unmixed data. You must select the appropriate worksheet to view the corresponding type of data. When viewing raw data, the parameters on the plots in a raw worksheet reflect the channel names, for example, B1-A, R1-A, V1-A. When viewing unmixed data, the parameters on the plots in an unmixed worksheet reflect the fluorescent tags, for example, PerCP-A.

Opening a Worksheet

To select a worksheet, click **Worksheet** in the Acquisition menu. The Select a worksheet menu appears (below). You can open a new raw or new unmixed worksheet. These worksheets open with a single FSC vs SSC plot. Use the worksheet tool bar to add plots and other elements. All worksheets are saved as template files (WTML) and can be opened using the **Open Worksheet Template** option. You can also import worksheets that were exported, as well as save, print, and save a worksheet PDF.

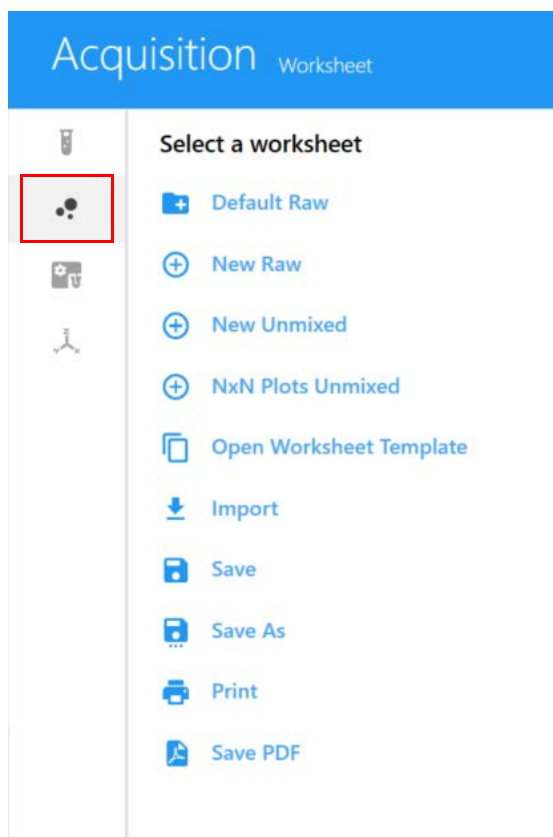

The following table describes the options in the Acquisition Worksheet menu:

Method	Description
Default Raw	Opens a default raw worksheet that can be used for experiments where reference controls will be acquired. Do not overwrite this worksheet. Always use Save As to save this worksheet with a new name.
New Raw	Opens a new raw worksheet.
New Unmixed	Opens a new unmixed worksheet.
NxN plots unmixed	Uses the fluorescent tags selected when setting up the experiment to create a worksheet with multiple plots, displaying each fluorescent parameter against each other. This worksheet allows you to check for potential unmixing errors and correct as needed.
Open Worksheet Template	Allows you to select from a list of saved worksheet templates. A default raw and default unmixed worksheet are provided.
Import	Imports a worksheet template that was exported.
Save, Save As, Print, Save PDF	Saves the worksheet, saves the worksheet with a new name, prints the worksheet, saves a PDF of the worksheet.

You can have multiple worksheets open at a time. The currently displayed worksheet appears with a blue line under the worksheet name. Because you can select different worksheets for different groups or tubes in an experiment, each tube will have a worksheet associated with it.

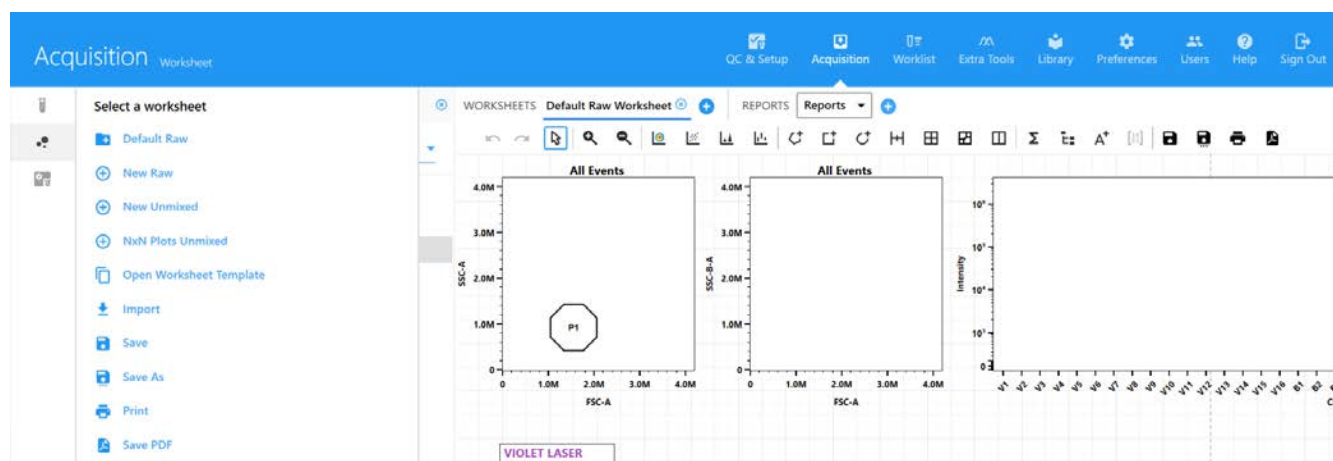

Each user can define a default raw worksheet and a default unmixed worksheet. Open the default worksheet and set it up for your experiment, then select Save As to save this worksheet with a new name. The worksheet will be available to select when you create an experiment. You can use this worksheet, open a template worksheet, or create a new worksheet.

All worksheets are saved in the library. See ["Worksheet Templates" on page 68](#) for more information on worksheet templates.

About Reports

The report is a static data display sheet that can display the data from one or more tubes. Experiments can be saved as Assays. An assay needs to contain at least one report. For more information, see "Create Reports" on page 60.

7 Color TBNK Assay		
Institution: Cytekbio Cytometer SN: 16889 Software: SpectroFlo® CLC & 1.0.1 (07142021)	Assay: 7C B Operator: Admin Page: Page 1 Of 1	Sample ID: Approve date: Status:

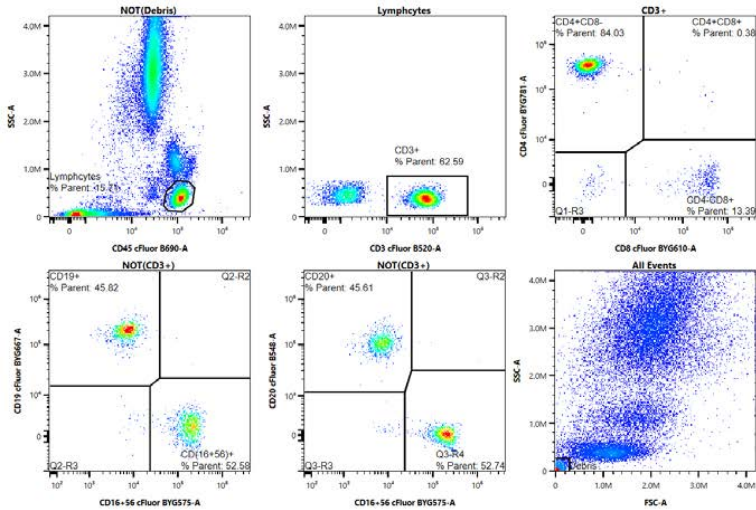

Gate	% Parent	% Grand Parent	Count/uL	Absolute Count
7C B_Lymphocytes	15.71	13.66	59.44	618.22
7C B_CD3+	62.59	9.83	37.21	386.95
7C B_CD3+CD4+	84.41	52.84	31.41	326.65
7C B_CD3+CD8+	13.77	8.62	5.12	53.29
7C B_CD19+	45.82	17.14	10.19	105.97
7C B_CD(16+56)+	52.58	19.67	11.69	121.60
7C B_CD20+	45.61	17.06	10.14	105.48
7C B_CD19+ AND CD20+	45.61	17.06	10.14	105.48
7C B_CD19+ OR CD20+	45.82	17.14	10.19	105.97

Signature:
REPORT NOT SIGNED
 Comments:

Startup & Shutdown

Filling the Sheath and Emptying the Waste

The color-coded sheath and waste quick-connects and the waste level sensor connector are located at the lower-left corner of the front panel.

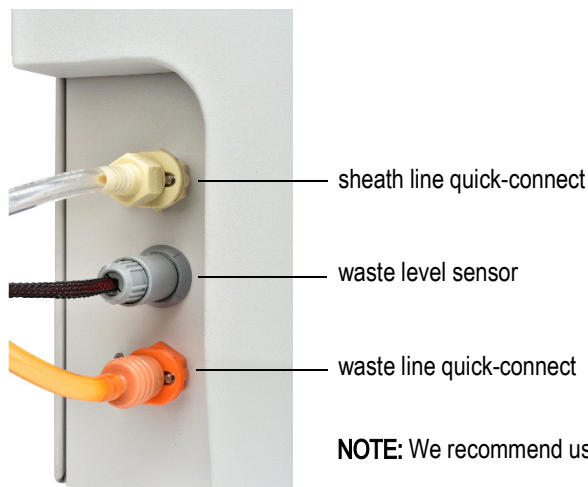

NOTE: We recommend using the 20-L cubitainers instead of the 4-L tanks for systems with a Loader.

Filling the Sheath

Fill the sheath container with manufacturer-provided sheath solution, MilliQ™ water, phosphate-buffered saline (PBS), or deionized (DI) water.

Sheath can be drawn from either the supplied 4-L sheath tank or directly from a 20-L cubitainer.

Sheath solution can be added to the sheath container while the instrument is running.



Before turning on the cytometer, visually inspect all containers for leaks or cracks. Wear the recommended protective laboratory attire such as protective gloves, eyewear, and lab coat.



Fill the sheath container as needed. Use only the appropriate sheath solution. Never use tap water or surfactant-based sheath solution.

Filling Sheath into a Cytek 4-L Sheath Tank or a 20-L Cubitainer

- 1 Remove the sheath fluidics line cap from the cubitainer or sheath tank lid from the sheath tank.
- 2 Add the appropriate sheath solution.
- 3 Replace the fluidics line cap or sheath tank lid. Do not over-tighten.
- 4 If the cytometer is powered on and the software is connected, verify that the software sheath indicator is green.

Warm Up Time Left: 00:29:31



Sheath



Waste



Cytometer



Loader

Emptying the Waste

Waste can be expelled into either the supplied 4-L waste tank or directly into an empty 20-L cubitainer.



Empty the waste container when filling the sheath container or as needed to prevent leakage. The software indicator for waste will be yellow or red when the container needs to be emptied. Take care to avoid damaging the fluid level sensor in the waste tank.



Biological samples are potentially dangerous and/or life threatening. Adhere to proper handling procedures for samples and reagents. Wear standard PPE laboratory attire such as protective gloves, eyewear, and lab coat during this procedure.



Always treat the contents of the waste container with household bleach (10% of the total volume). Contents of the waste container may contain biohazardous material.

Removing Waste from a Cytek 4-L Waste Tank or a 20-L Cubitainer

- 1 Disconnect the waste line orange quick-connect from the cubitainer cap or 4-L waste tank. Disconnect the waste level sensor.
The waste level sensor connector for the cubitainer is on the cubitainer cap. The waste level sensor connector for the 4-L tank is on the front of the cytometer.
- 2 Remove the waste cap from the cubitainer or the lid from the 4-L waste tank, taking care not to damage the liquid level sensor.
- 3 Dispose of the waste per local regulations.
- 4 Add 2 L of undiluted bleach to the waste cubitainer, or 400 mL of bleach to the waste tank.
- 5 Replace the waste cap/lid to the container. Hand-tighten the cap/lid until it is fully closed.
- 6 Reattach the waste line and level sensor line to the cap/lid and front of the cytometer.
- 7 If the cytometer is powered on and the software is connected, verify that the software waste indicator is green.

Starting Up the System

- 1 Turn on the workstation, then turn on the cytometer.
 - **NOTE:** Ensure that a tube containing 1 mL of deionized (DI) water is loaded on the SIP before launching SpectroFlo software. The tube is required for the SIT depth calibration and to flush liquid through the flow cell to remove bubbles that may have formed.
- 2 Launch SpectroFlo software and log in by entering your user name and password and clicking **SIGN IN**.

You can start typing your user name to display a list of names beginning with the letter(s) you type.

The cytometer initialization procedure begins. Sheath fluid is flushed through the fluidics lines to prevent any saline buildup, and the system calibrates the SIT depth.

- 3 Select **QC & Setup** from the Get started menu.

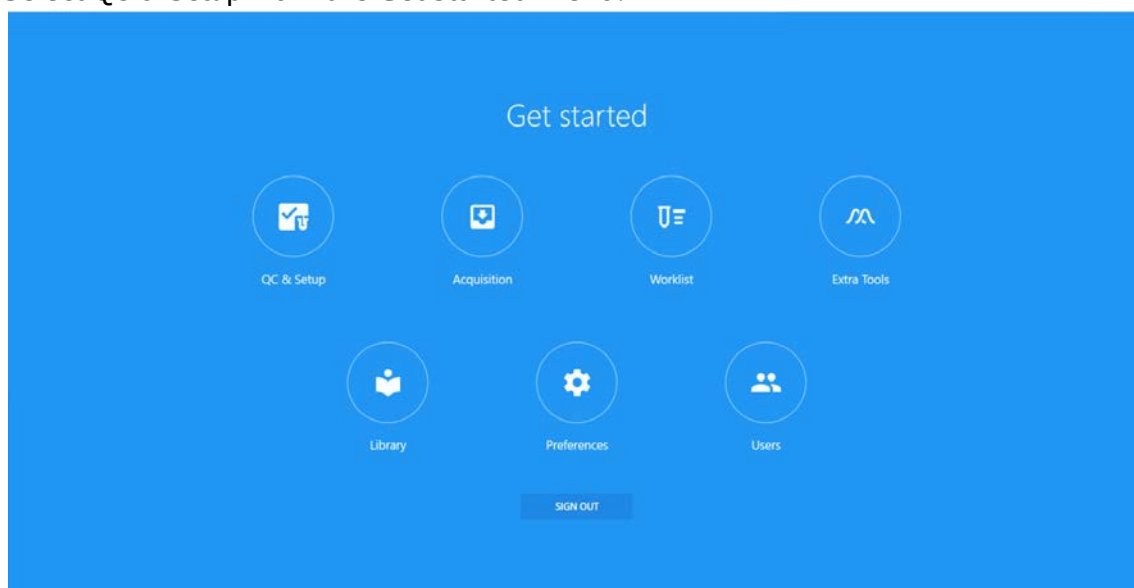

- 4 Check the status indicators in the lower-right corner of the screen.
 - Ensure the indicator for **Connected** is a green checkmark. It may take a few minutes for the indicators to update.

Warm Up Time Left: 00:29:31 ✓ **Sheath** ✓ **Waste** ✓ **Cytometer** ✓ **Loader**

If the indicator shows the instrument is not connected, check to ensure that the USB connection between the cytometer and workstation is plugged into the appropriate ports. See ["Back of Cytometer"](#) on page 13.

- Ensure the status indicators for sheath and waste are green before proceeding.

Fluid Indicator	Meaning	What to do
Yellow sheath	Sheath tank is low. Acquisition will continue for 5 minutes before the sheath is empty. You can refill the sheath during this time.	Fill the sheath tank (see “Filling the Sheath” on page 25).
Red sheath	Sheath tank is empty.	
Yellow waste	Waste tank is nearing capacity.	Empty the waste tank (see “Emptying the Waste” on page 26).
Red waste	Waste tank is full.	

- 5 Wait 30 minutes before running samples. See [“Performing Daily QC” on page 29](#). We recommend running a tube of DI water during the warm-up period. You cannot record a file until the 30 minute warm-up period is complete.

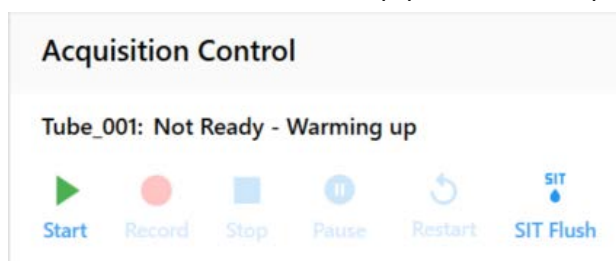

■ **NOTE:** Administrators can select Enable data collection during system warm up under Preferences > Cytometer. This bypasses restrictions imposed by default during instrument warm-up, such as data acquisition and Daily QC.

Shutting Down the System

Run the shutdown procedure at the end of each day that you use the instrument.

The shutdown procedure flushes the flow cell and sample lines with 10% bleach solution, DI water, 25–50% Contrad 70, and DI water. The procedure takes approximately 5 minutes. The SIT will remain extended from the SIP at the end of shutdown to ensure the SIT does not dry and form clogs.

To shut down the system:

- 1 Follow the Fluidics Shutdown procedure. See [“Fluidics Shutdown” on page 134](#).
- 2 When the shutdown procedure is complete, exit SpectroFlo software by clicking the X in the upper-right corner of the application window.
- 3 Turn off the cytometer and workstation.

QC & Setup

Daily QC

Run Daily QC using SpectroFlo QC beads prior to acquiring samples to ensure that the cytometer is performing optimally. Daily QC assesses the instrument's optical alignment and the system performance drift by measuring rCVs and gains needed to place the beads at the target locations for each detector. During QC, laser delays and area scaling factors are optimized and gain settings are adjusted to account for day-to-day instrument variability. Upon completion of Daily QC, a QC report is generated. QC reports can be reviewed under the Reports tab.

Performance can be tracked and charted over time in the Levey-Jennings tab. The software can be configured to display a warning if the QC result on the QC report exceeds user-defined criteria. See ["Alarm Ranges"](#) on page 41.

Performing Daily QC

- 1 Allow 30 minutes to pass after turning on the system to ensure the optics compartment is warmed up.
- 2 Prepare SpectroFlo QC beads (1 drop of beads in 0.3 mL of sheath solution or PBS).

■ **NOTE:** Always prepare beads in the same solution used for the sheath solution on the instrument. The bead diluent and instrument sheath solution must match. If you use DI water to prepare the beads, the beads will begin to degrade within a few hours. Do not reuse the beads prepared in DI water.

The SpectroFlo QC beads are 3- μm hard-dyed, polystyrene beads that have a single fluorescence intensity. They can be excited by each laser and emit fluorescence in all detector channels.

3 Select QC & Setup from the Get started menu.



4 Select the current bead lot from the Bead Lot menu.

Each time you open a new lot number of SpectroFlo QC beads you must import the bead lot ID into the library so it is accessible when you run QC. Bead lot files can be downloaded from the Resources section at <http://www.cytekbio.com>.



Different bead lots have different fluorescence intensities. Always select the correct bead lot when performing Daily QC.

5 Start acquisition:

- Tube: Load a 12 x 75-mm tube of the beads onto the SIP. Select Start to begin acquisition.



- Loader: Ensure the correct plate type is selected (96 U-, V-, Flat-Bottom, deep well, or 40-tube rack). Click in the plate or tube in the tube rack to select the well or tube where the QC beads

are located. Well A1 is selected by default, but you can choose any well. Select Eject, load the plate onto the stage, then click Load followed by Start to begin acquisition.

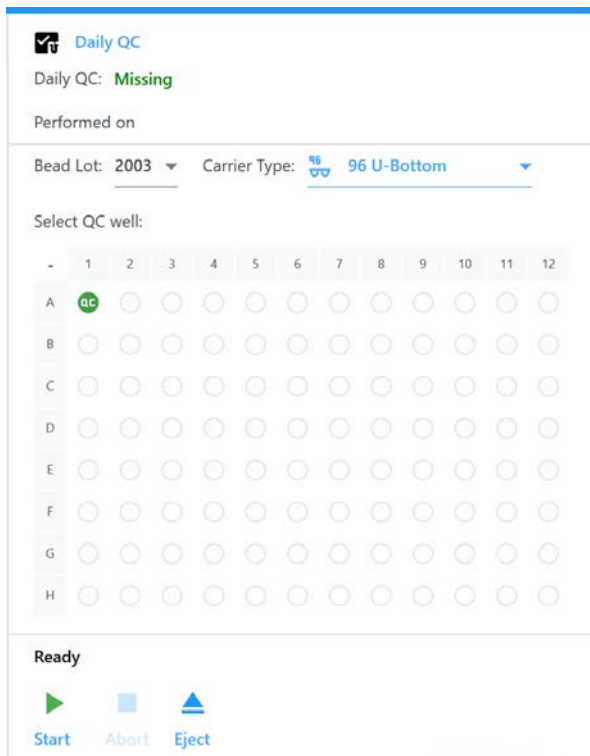

As the instrument begins acquiring the QC beads, they appear in the scatter plot. The laser delays are initially set to 0, then optimized thereafter. The performance measurements are established and compared to the pass/fail criteria (see [“Pass/Fail Criteria” on page 32](#)).

The procedure takes approximately 3 to 5 minutes to complete. Once acquisition is complete, two SIT Flushes are automatically performed to clear the beads from the sample line.

The following message is displayed when Daily QC passes. To view the QC report, click View Report (see [“QC Report” on page 32](#)).

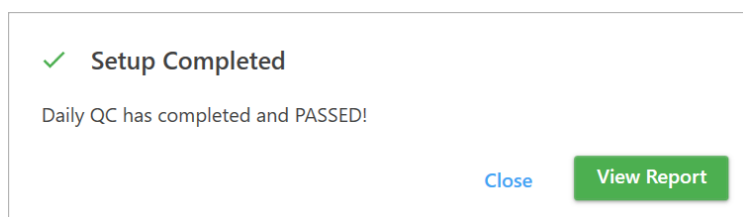

If QC fails, remove the tube or plate and follow the guidelines that appear. The recommended solution will vary depending on the reason for the failed test.

Daily QC Failed

Daily QC failed to place the QC beads on scale.

Please try the following:

1. Make sure the concentration of your beads sample is appropriate (between 100 - 1000 events per second).
2. Go to Acquisition to run your beads sample in an experiment and make sure your sample is appropriate.
3. Remix your beads sample run QC again.

If the problem persists, please contact Cytek Service.

OK

You are now ready to run reference controls, if applicable, or acquire samples.

QC Report

At the completion of Daily QC, a QC report is generated. The report includes the following sections:

- The header section contains the Pass/Fail status of the run, name of the instrument, instrument configuration, date the Daily QC was run, user who ran the Daily QC, instrument serial number, and SpectroFlo QC bead lot and expiration date.
- The results section contains the gain, gain change, median fluorescent intensity of the QC bead, %rCV, and a pass/fail indicator for each detector channel. The center wavelength of the detector is shown in parentheses next to the detector name.
- The Laser Settings section contains the laser delays for all non-primary lasers, and area scaling factors for all lasers and the FSC detector.

Pass/Fail Criteria

The pass/fail criteria are the following:

- %rCV must not exceed 6% for the FSC channel
- %rCV must not exceed 8% for the SSC and SSC-B channels
- %rCV must not exceed 6% for the third channel of each laser (V3, B3, and R3)
- % delta gain change for all channels must not exceed 100% from the last Daily QC run performed by Cytek Service personnel.

QC reports are automatically exported as CSV files to the Setup folder (C:\CytekbioExport\Setup). The number of reports listed in the Reports screen can be set in the Preferences. See [“QC Setup Preferences” on page 80](#) for more information.

An example QC Report is shown.

Daily QC Report

Setup Status:	PASSED	Date:	October 28, 2017 - 17:03 PM
Cytometer Name:	MyCyto	User:	Admin
Configuration:	3-Lasers-V16-B14-R8	Serial Number:	R0001
QC Beads			
Lot ID:	1002	Expiration Date:	December 31, 2019

Lasers	Detector (nm)	Gain	Gain Change	Median (x1000)	% rCV	Status
Blue	FSC	174	-26	1,843.2	2.57	✓
Violet	SSC	342	9	2,087.8	4.45	✓
Violet	V1 (428)	381	55	202.2	3.96	✓
Violet	V2 (443)	212	19	205.7	3.97	✓
Violet	V3 (458)	201	17	202.5	4.11	✓
Violet	V4 (473)	153	19	244.1	3.98	✓
Violet	V5 (508)	197	13	302.0	4.04	✓
Violet	V6 (528)	248	12	243.1	4.04	✓
Violet	V7 (549)	233	13	182.7	4.01	✓
Violet	V8 (571)	256	19	123.1	3.79	✓
Violet	V9 (594)	251	14	102.5	3.80	✓
Violet	V10 (618)	381	18	91.0	3.78	✓
Violet	V11 (664)	638	46	72.6	3.73	✓
Violet	V12 (692)	974	59	60.6	3.71	✓
Violet	V13 (720)	530	36	31.5	3.75	✓
Violet	V14 (750)	531	40	21.0	3.88	✓
Violet	V15 (780)	793	75	10.8	5.96	✓
Violet	V16 (812)	461	35	4.2	7.93	✓
Blue	B1 (508)	231	2	14.1	2.62	✓
Blue	B2 (528)	242	-10	38.7	2.03	✓
Blue	B3 (549)	221	-10	94.4	1.63	✓
Blue	B4 (571)	240	-13	134.2	1.66	✓

Red	R7 (783)	895	-9	79.4	5.85	✓
Red	R8 (812)	326	0	39.3	6.11	✓

Laser Settings

Lasers	Laser Delay	Area Scaling Factor
Violet	-24.95	1.19
Blue	0.00	1.20
Red	27.50	0.85

FSC Area Scaling Factor: 1.24

Specifications

FSC	% rCV:	< 6	(Recommended)
SSC	% rCV:	< 8	(Recommended)
V3	% rCV:	< 6	(Recommended)
B3	% rCV:	< 6	(Recommended)
R3	% rCV:	< 6	(Recommended)
All Channels	% Gain Change:	< 100	(Recommended)

Reference Controls

Reference controls, obtained by running single-stained and unstained samples, provide the individual fluorescence spectra necessary to unmix the data. Either beads or cells can be stained for use as reference controls. These controls can be acquired in the reference group of the experiment during acquisition, or they can be acquired as reference controls in the QC & Setup module. If reference controls are acquired in the QC & Setup module, they are stored and can be used as reference controls for unmixing in subsequent experiments.

A wizard guides you through recording reference controls.

Running Reference Controls

To create reference controls you will need to select the fluorescent tags, choose the control type (beads or cells), then label the fluorescent tags (for example, using CD nomenclature). You can also append existing FCS files when running reference controls.

Run Daily QC to ensure the instrument is performing optimally before running reference controls.

- 1 Select Reference Controls from the QC & Setup module.
- 2 Select New Reference Controls from the Reference Controls tab.

A wizard opens allowing you to create new reference controls. You can also append existing FCS files.



- 3 Select the fluorescent tags. The left pane displays the fluorescent tag groups found in the library.
 - Click the arrow to the left of the fluorescent tag group name to view the fluorescent tags in the group. (The default fluorescent tag groups are Blue Laser, Red Laser, Violet Laser, Fluorescent Proteins, and Viability Dyes and contain a list of commonly used fluorescent tags excited by their respective laser).
 - From the expanded list of fluorescent tags, select the fluorescent tags used in the experiment. Once selected, the fluorescent tags appear in the selection pane on the right. You can select fluorescent tags by dragging and dropping, double-clicking, or using the Add button. Multiple tags can be chosen at one time. Confirm the tags selected, then click Next.

■ **NOTE:** The list of fluorescent tags can be edited in the library. You can use the library to add fluorescent tags that are not present in the default list. See “Fluorescent Tags” on page 63 for more information.

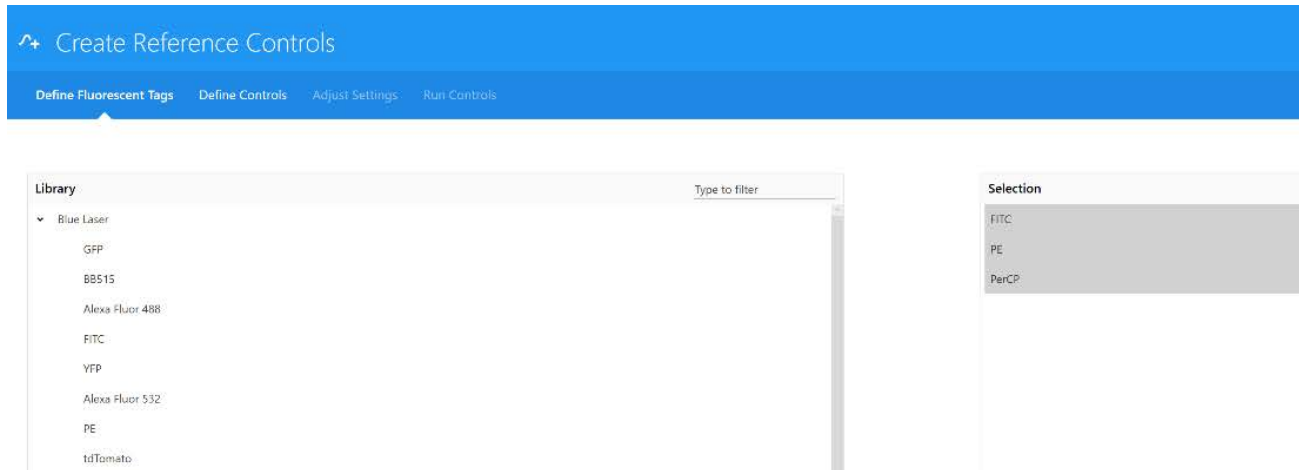

4 Define the unstained control(s).

Choose either single-stained fluorescent tags, or new, separate, unstained for the control tubes. If using a control that has a positive population only, you will need an unstained control of the same type as the stained.

Either beads or cells can be stained and defined as control types. If you select Use new, separate, unstained tube(s), you can add more unstained tubes, as necessary. Then select the specific unstained tube in the Negative Control column of the Fluorescent Tags table below.

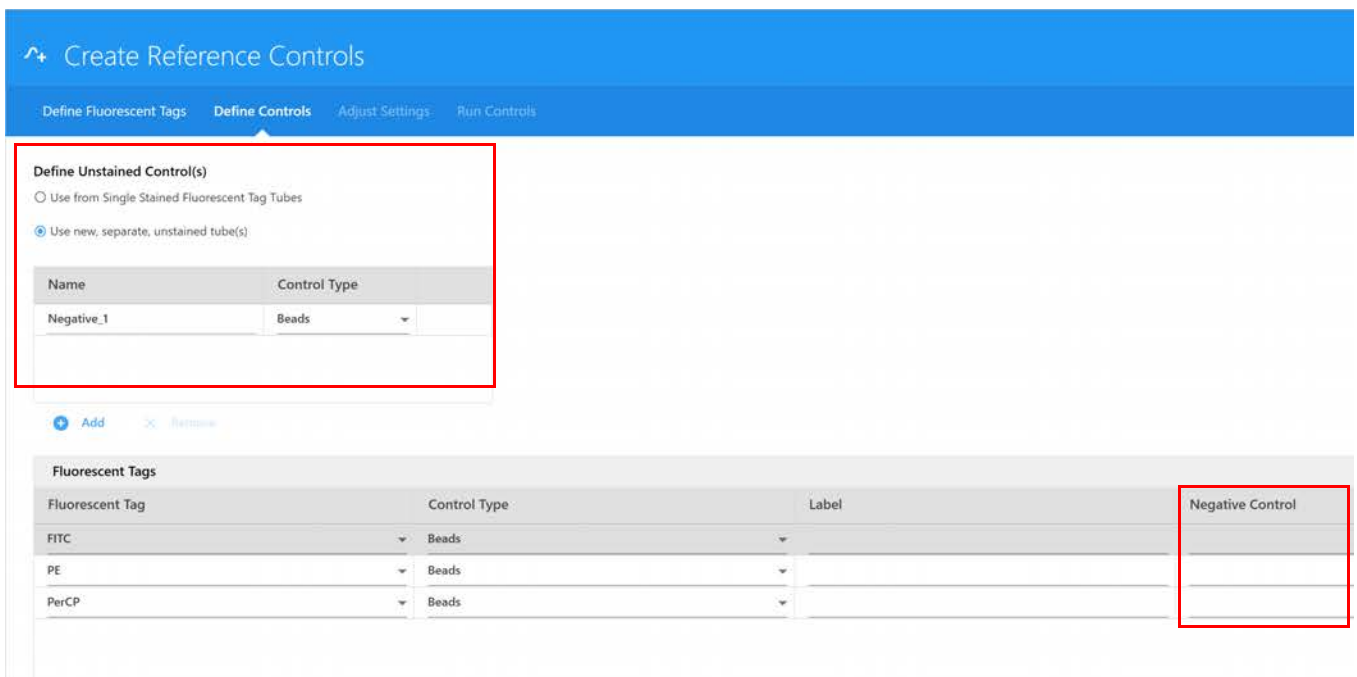

5 Define the control type (beads or cells) for each fluorescent tag in the Fluorescent Tags table.

6 (Optional) Enter labels associated with the fluorescent tag for identification and tracking.

7 If applicable, enter the lot number(s) of the reference controls.

■ **NOTE:** If you selected Label/Lot Specific Unmixing in the Acquisition Preferences (see [page 72](#)), the software will search the library and experiment reference groups for reference controls that have the same fluorescent tag, label, and lot information in order to use the corresponding control for unmixing.

Define Unstained Control(s)

Use from Single Stained Fluorescent Tag Tubes
 Use new, separate, unstained tube(s)

Name	Control Type
Unstained_1	Beads
Unstained_2	Beads

+ Add X Remove

Fluorescent Tag	Control Type	Label	Lot
FITC	Beads		
PE	Beads		
PerCP	Beads		

- Once the controls have been defined, click Next.
- Load the control sample onto the SIP and click Start to preview the sample data. This step allows you to ensure that all populations for all control samples are on scale. If necessary, adjust gain settings.

Gain setting for all channels for each laser detector module can be adjusted. Adjust the detector using the all channels % feature. Adjust the same percentage for all lasers to maintain the fluorochrome signature. To save this customized setting, click the Save button in the Instrument control pane and rename.

Instrument Control ⚙️

User Settings: CytekAssaySetting (Cytek) Save Save As

GAIN		THRESHOLD	SIGNAL	LASERS	
FSC	SSC	SSC-B			
50	50	50			
Violet		Blue	Red		
V1	V2	V3	V4	V5	
4	11	13	13	12	
V6	V7	V8	V9	V10	
9	9	5	4	3	
V11	V12	V13	V14	V15	
1	0	0	0	0	
V16					
0					
All Channels %:		0			

■ **NOTE:** CytekAssaySetting was generated by measuring the optimal resolution of human lymphocytes stained with CD8 and CD4 labeled with various fluorochromes. These settings provide a place to start for most immunophenotyping applications.

The Adjust Settings screen allows you to view the data to ensure that the positively stained fluorescent particles are on scale. Adjust the threshold and FSC and SSC gains. FSC gain can be adjusted from 1-1,000. SSC and detector channel gains can be adjusted from 10-10,000. If the positive population is off-scale for any detector channels, lower the gain setting for that detector module, and then lower by the same percentage for each laser in the instrument. This will preserve the fluorochrome signature.

If the positive population is not sufficiently separated from the negative population within a specific channel, verify that CytekAssaySetting is selected, as these settings ensure adequate resolution. If the positive population is still not clearly separated from the negative population, review the sample preparation and staining procedure.

Once gain settings have been confirmed, unstained and reference controls are ready for acquisition.

■ **NOTE:** Dim markers may not separate from the negative population regardless of how much the gain is increased.



10 Preview the data for the remaining controls by clicking Stop, then:

- Tube mode: Loading the next control onto the SIP and clicking Start.
- Plate mode: Selecting the next control well and clicking Start.

11 Select Next when you are satisfied with the gain settings. Proceed to running controls.

12 If you are running in Tube mode, place a tube of the appropriate single-stained particles on the SIP.

13 Click Record to begin acquiring.

Make sure to follow the order listed in the left-hand panel.

During acquisition the spectra plot for each fluorescent control is displayed. The plots show all the channels across all lasers in the x-axis vs mean fluorescence intensity (MFI) of the fluorescent tag.

If the acquisition criteria is not met within 15 minutes, the run will stop.

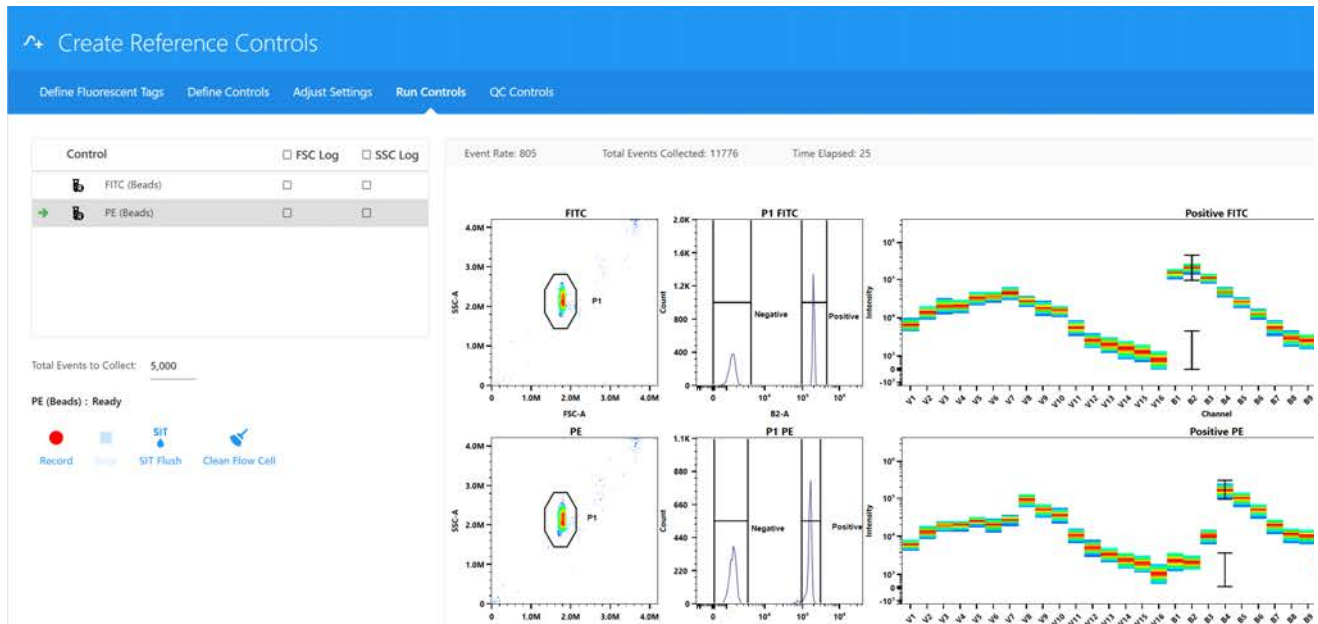

14 During acquisition, obtain spectral information by moving the polygon gate on the FSC-A vs SSC-A plot to include the population of interest.

Hold down the Ctrl key while adjusting the gate to move the polygon gates for all the scatter plots at once. The gated population appears in the histogram, which is set approximately to the peak emission channel of the fluorescent tag to be acquired. The emission spectrum of the population is displayed in the spectrum plot.

Adjust the positive gate on the histogram. The software automatically displays the emission spectrum of the positive particle in the spectrum plot. SpectroFlo software sets the default gate near or on the peak emission channel. The gate can be selected manually. It is best to set the gate on the brightest emission, as this can make distinguishing the positive and negative populations easier and provides better visualization of the spectrum.

■ **NOTE:** Unmixing results are unaffected by the position of the interval gate in the spectrum plot.

Readjust the positive and/or negative gate on the histogram, if necessary.

15 Continue recording each control.

16 Select Save to save the reference controls.

FCS files for saved reference controls are stored in the export Setup folder by default, or the folder you set as the default. See [“Storage Preferences” on page 78](#) for information.

Setting Reference Controls as Benchmarks for Reference Control QC

You can select reference controls to be used as benchmarks for QC. The reference controls you select as benchmarks allow you to check the quality of your reference controls prior to unmixing. If a reference control is suboptimal, the benchmark will indicate whether the reference control spectra appears as expected. If you choose not to designate reference controls as benchmarks, the reference controls run during QC & Setup or during the experiment will be used as-is without a quality control check.

NOTE: Before saving a reference control as a benchmark, ensure that it is fully optimized.

- 1 Select Reference Controls from the QC & Setup module.
- 2 Select Benchmark from the Reference Controls tab.

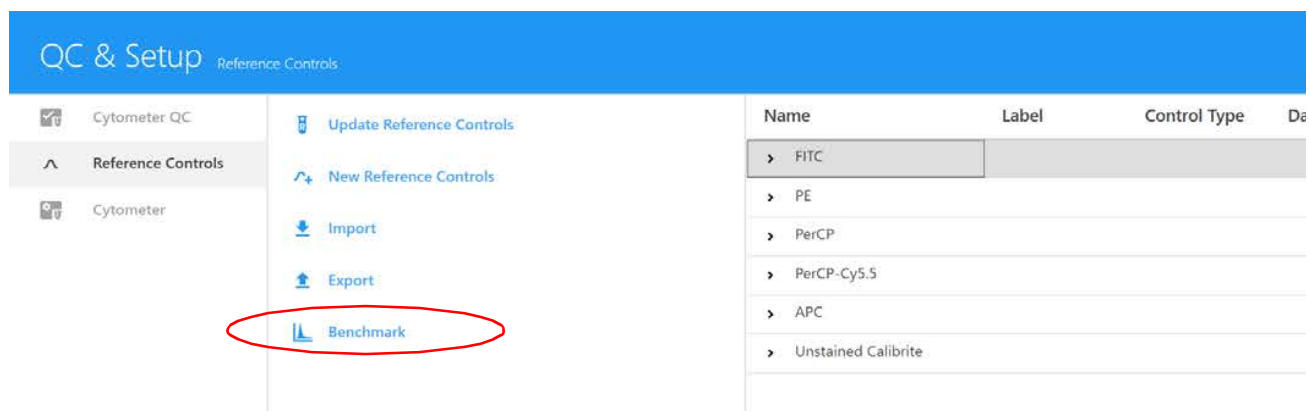

- 3 Select the reference controls that will be the benchmarks.

Click All to select all the controls in the list.

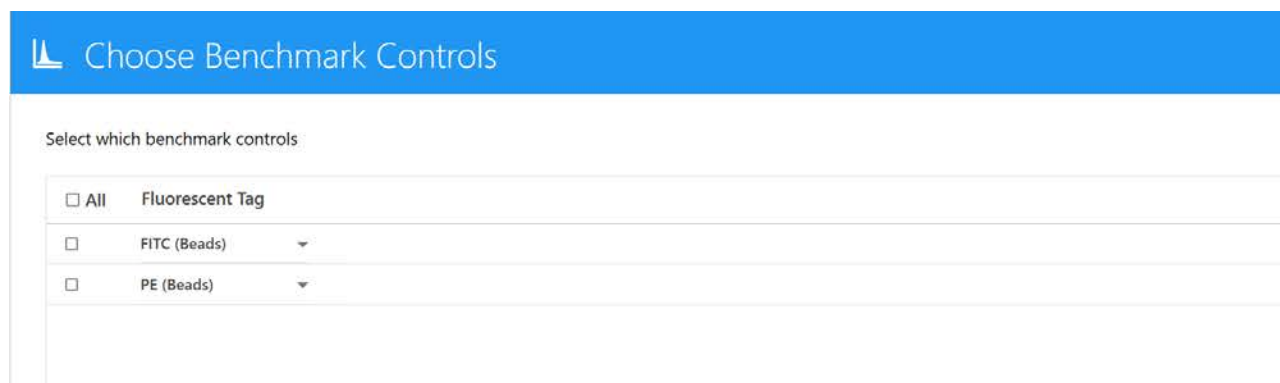

- 4 Click Save.

Updating Reference Controls

You may wish to update the reference controls if any of the following occur:

- Major service performed on the instrument
- Fluorochrome exhibiting signs of instability resulting in changes in its emission spectrum
- Staining protocols change, for example different buffers or fixatives are used

The Reference Controls tab displays the reference controls saved in the library. Click the arrow next to the control name to display the details.

To Update Reference Controls

- 1 Select Update Reference Controls from the Reference Controls tab in the QC & Setup module. A wizard opens allowing you to update reference controls.

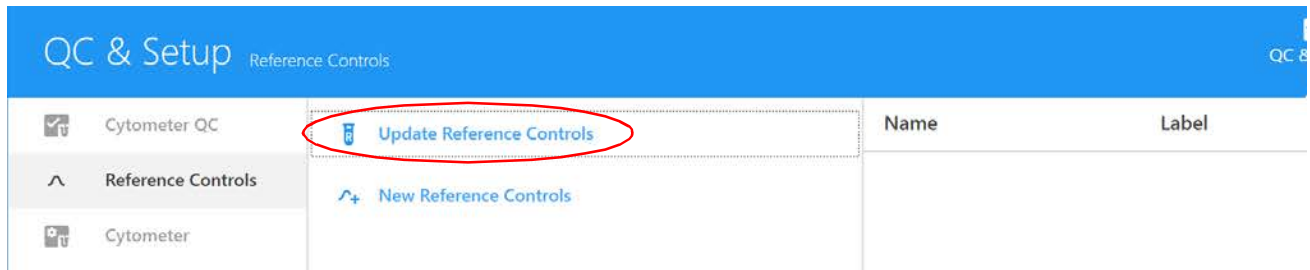

- 2 Follow steps 3 through 11 in “Running Reference Controls” on page 34.

Levey-Jennings Tracking

Levey-Jennings tracks the gain and CV's for all detector channels and the laser delays and area scaling factors for each laser over time. This allows you to view the system's performance. Select the parameter(s) you wish to track.

The graphs in the report show you random errors or shifts and trends in the data for each parameter. Data from the last 30 days, 3 months, or 12 months can be included in the reports.

- 1 Select a parameter checkbox to display the Levey-Jennings plot.
- 2 Use Save Selection to save the LJ tracking settings.

3 To export Levey-Jennings data to a .csv file, click Export Data.

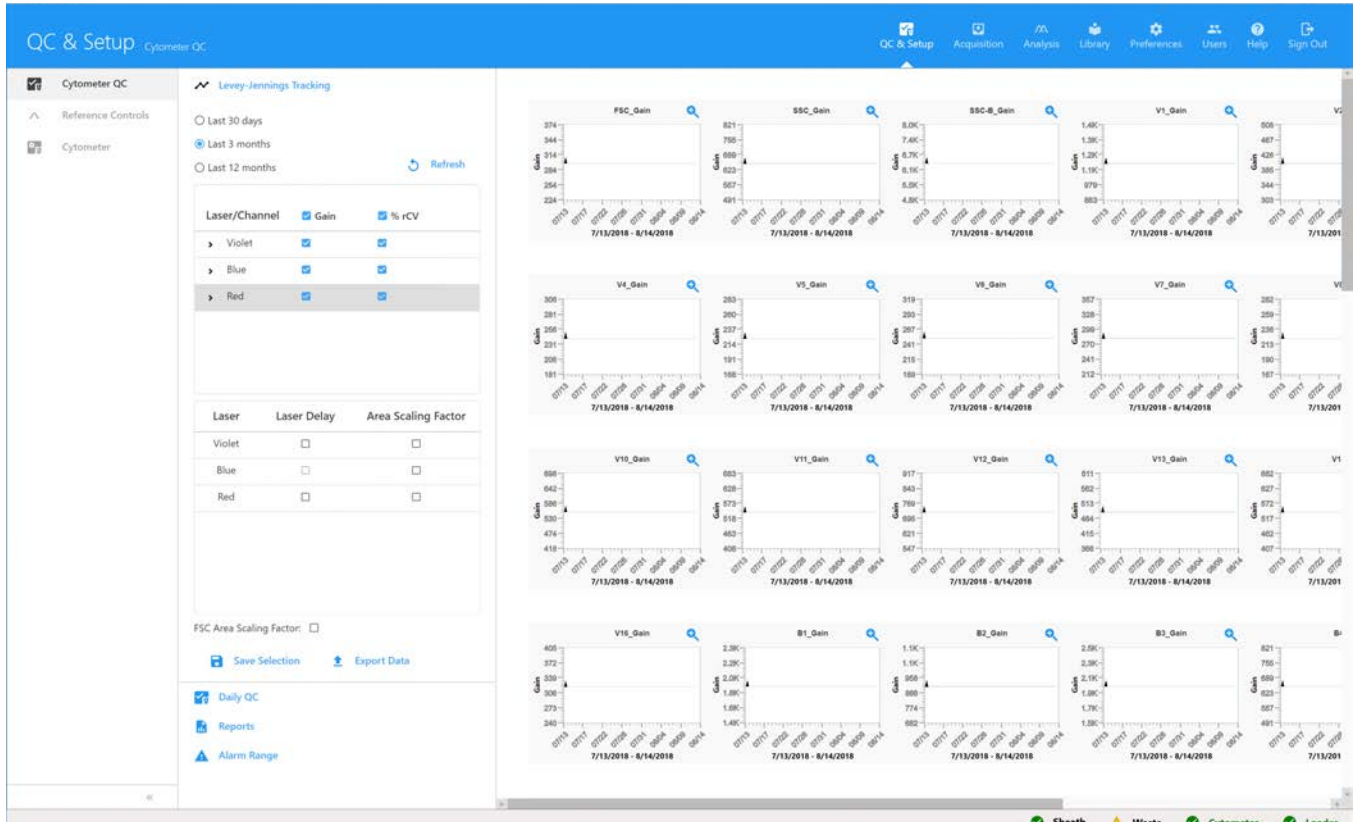

Gain Settings

The amount of signal amplification applied to each detector channel can be modulated by increasing or decreasing the amount of gain applied. The gains for every detector channel can be saved and are collectively known as the user settings. User gain settings are stored as a ratio against the Daily QC. Every time Daily QC is performed, User Settings will be adjusted accordingly.

Alarm Ranges

You can set an alarm to warn you when the gain and %rCV exceeds the passing criteria that you define. This changes the outliers (shown in red) in the LJ graphs. Select Alarm Range from the Cytometer QC tab, then adjust the SD range (plus or minus) for individual detectors for each laser.

Parameter	Alarm Criteria	Min	Max
Gain	+/- 3SD	0	0
> Violet	+/- 3SD	0	0
> Blue	+/- 3SD	0	0
> Red	+/- 3SD	0	0
% rCV	+/- 3SD	0.00	0.00
> Violet	+/- 3SD	0.00	0.00
> Blue	+/- 3SD	0.00	0.00
> Red	+/- 3SD	0.00	0.00
Laser Delay	+/- 3SD	0.00	0.00
Violet	+/- 3SD	0.00	0.00
Red	+/- 3SD	0.00	0.00
Area Scaling Factor	+/- 3SD	0.10	3.00

Acquisition

Raw vs Unmixed Data

SpectroFlo software saves flow cytometry data in the FCS 3.1 format. Data is saved in both raw and unmixed formats. Raw data contains all the fluorescence information from each detector (ie, V1, V2, V3, etc). Each detector channel is designated by its excitation laser and position in the array. For example, B3 is the third channel of the blue laser detector array.

Unmixed data contains all the fluorescence information from each fluorescent tag in the experiment. To unmix data, single stained controls (or reference controls) for each of the fluorescent tags (as well as an unstained control) are required. During unmixing a mathematical algorithm is used for the decomposition of the fluorescent components in the sample using the reference controls. Parameters in unmixed data will display as the fluorescent tag name along with their associated labels.

The Acquisition module provides the tools that allow you to create an experiment. An experiment is a set of tubes, instrument settings, acquisition criteria (stopping rule), fluorescent tags, labels, and worksheets designed for the acquisition of samples. See [“About Experiments” on page 18](#).

New and saved experiments can be created or accessed in the Experiments tab of the Acquisition module.

Unmixing and Compensation

Raw FCS files can be spectrally unmixed in the following ways:

- Reference group from the experiment – Reference controls collected as FCS files within the experiment can be used to unmix using the Unmixing wizard in the Acquisition module.
- Reference controls run in QC & Setup module – Reference controls run in the QC & Setup module can be used to unmix using the Unmixing wizard in the Acquisition module.
- Unmixing from the Extra Tools module – FCS files collected from different experiments can be unmixed in the Extra Tools module. FCS files can be imported and unmixed in this module.

Raw FCS files can also be compensated with the conventional method using the Virtual Filters tab in the Extra Tools module. Detector channels can be binned together to simulate the analysis of the data as if it were acquired using a filter. See [“Virtual Filters” on page 102](#) for more information.

Setting Up an Experiment

An experiment can be saved as a template or created for one time use. Setting up the experiment in SpectroFlo software involves:

- 1 (Optional) Providing a name and description for the experiment. A default name is provided.
- 2 Specifying the fluorescent tags used in the experiment.
- 3 Defining the reference group with associated reference tags, labels, and lot numbers, as needed.
- 4 Adding labels and lot numbers to each of the fluorescent tags.
- 5 Adding custom keywords. Custom keywords can be defined in the Library.
- 6 Selecting an acquisition worksheet—either new or a template.
- 7 Defining acquisition criteria (stopping rule based on events, time, or volume).

Acquisition Experiment Overview

The Acquisition module provides the necessary elements for data collection within the experiment. Click the Experiment icon in the far left pane to open a template, the default, or a new experiment using the wizard.

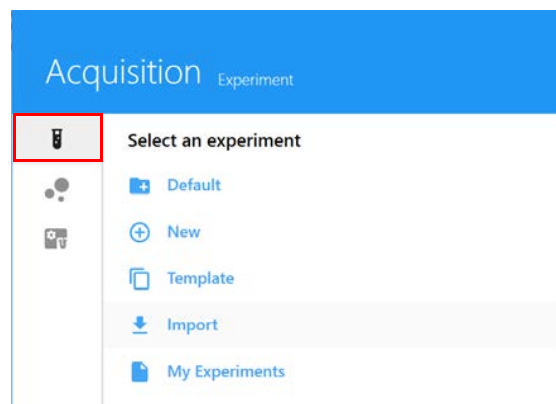

Experiment Display

The experiment display in the Acquisition module includes the following panes. To show, hide, or undock (float) these panes from the experiment panel, click the corresponding icons in the top-right corner of the pane.

Group-Tube List and Hierarchy

The samples are listed in the upper left of the screen. Samples can be organized into groups. Use the (+) Tube and (+) Group icons to add tubes and groups. If running from a Loader, click Add Plate or Rack to add a new sample carrier. Click Plate View to display a graphic image of the carrier instead of the list of groups.

Click **Save** to save changes to the experiment, or click **Save As** to save an experiment template. Click **Edit** to edit the experiment. Worksheets can be applied to the experiment, groups, or individual tubes.

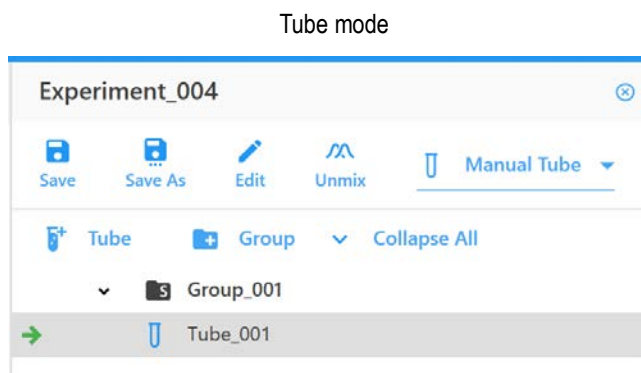

Acquisition Control

The Acquisition Control pane allows you to start, stop, and pause acquisition, record data, and restart acquisition counters. The acquisition controls are enabled when a tube is present on the SIP. To show, hide, or undock (float) this pane from the experiment panel, use the dock/undock and hide icons in the top-right corner.

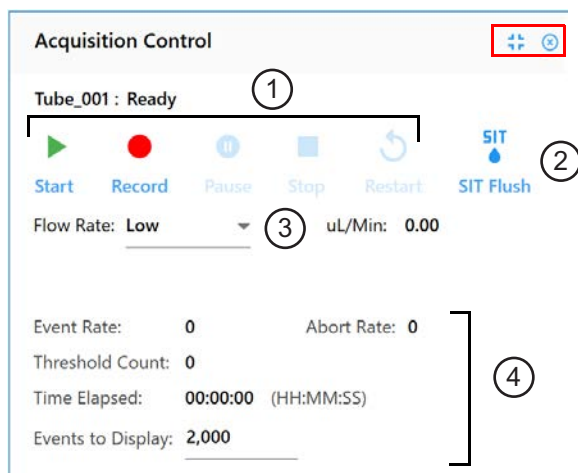

The following table describes the controls in the Acquisition Control pane.

No.	Control	Description
1	Start/Record/Pause/Stop/Restart	Start and Record are enabled when a tube is present on the SIP. Select Start to start acquisition Select Record to record data. Record can also start acquisition. Select Pause to pause recording. While paused you can adjust the flow rate. Select Record again to continue. Select Stop to stop acquisition. Select Restart to restart the acquisition counters. All events and results displayed are refreshed. Stop and Restart are enabled once Start is selected. Stop and Pause are enabled once Record is selected.
2	SIT Flush	Select to perform a SIT Flush

No.	Control	Description
3	Flow Rate	Select Low (15 $\mu\text{L}/\text{min}$), Medium (30 $\mu\text{L}/\text{min}$), or High (60 $\mu\text{L}/\text{min}$). The exact flow rate is displayed.
4	Event Rate, Abort Rate, Threshold Count, Time Elapsed	Displays the real-time counts during acquisition.
5	Events to Display	Enter the number of events to display during acquisition.

Instrument Control

The Instrument Control pane consists of the Gain, Threshold, Signal, and Lasers tabs for use in adjusting the instrument settings.

User Settings allows you to select CytekAssaySetting, Default, or any saved user settings for the experiment. We recommend using CytekAssaySetting as a starting point. This setting provides the optimal resolution for each channel, accommodates bright signals, and minimizes spread. While using CytekAssaySetting, you will need to only adjust FSC, SSC gains, and Threshold.

The screenshot displays the Instrument Control interface with four tabs: GAIN, THRESHOLD, SIGNAL, and LASERS. The GAIN tab is selected, showing gain settings for FSC (299), SSC (656), and SSC-B (456). The THRESHOLD tab is also visible, showing a threshold of 100,000 for the FSC channel. The SIGNAL tab shows scatter channel settings for FSC, SSC, and SSC-B, with Area and Height checked for each. The LASERS tab shows area scaling factors for Violet (1.19), Blue (0.93), and Red (0.99).

The following table describes the tabs in the Instrument Control pane.

No.	Tab	Description
1	Gain	<p>Gains can be adjusted for all detector channels for all lasers using the gain spinboxes. FSC gain can be adjusted from 1–1,000. SSC and fluorescence detector gains can be adjusted from 10–10,000. To change the value that the gain increments, see “Acquisition Preferences” on page 71.</p> <p>Use All Channels % to increase/decrease all gains for a selected laser by the percentage you select.</p>
2	Threshold	<p>Use the Threshold tab to set the threshold parameter and minimum threshold channel value. Multiple parameters can be set as a threshold using either the AND or OR operator. Use OR when at least one parameter is available.</p>
3	Signal	<p>Use the Signal tab to select area, height, or width for each signal. Area and height can be selected for all channels. Width can be selected for only one channel per laser.</p>
4	Lasers	<p>Use the Lasers tab to set the area scaling factor and laser delay. These values are automatically set and updated in all user settings upon completion of the Daily QC.</p> <p>■ NOTE: If you run large cells and the lowest FSC gain setting is not low enough to see your cells, lower the FSC area scaling factor (for example, 0.5).</p>

Worksheet

The worksheet allows you to view the data in plots and create plots, statistics, population hierarchy, and gates. Click the worksheet icon in the far left pane to select, import, save, and print worksheets.

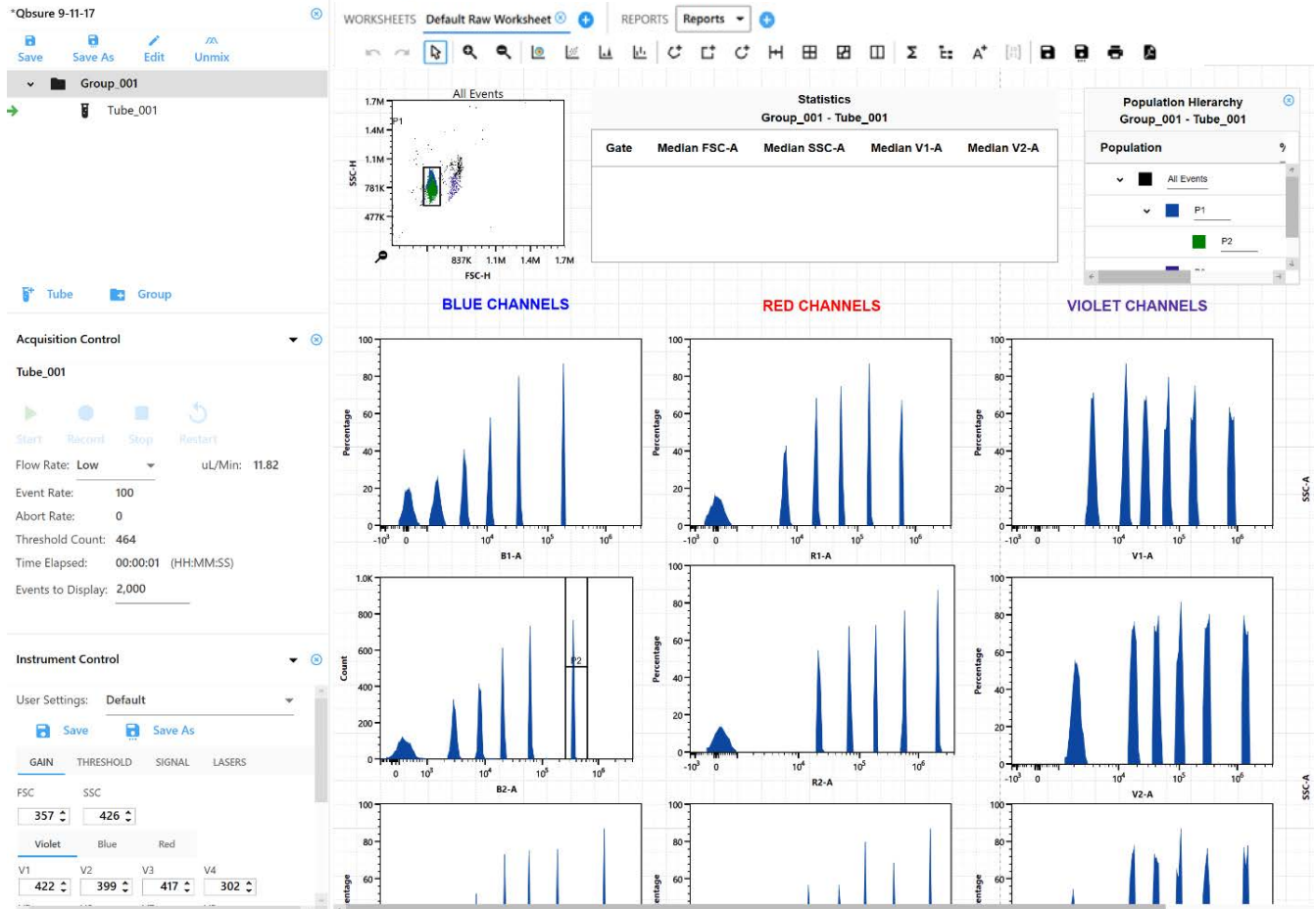

Worksheet Toolbar

A toolbar at the top of the worksheet area allows you to undo/redo, zoom; create plots, gates, statistics, population hierarchy, annotations; and save, print, and save a PDF of the worksheet. Hover the cursor over an icon to see a description and keyboard shortcut.



Plots

Four plot types can be created in the worksheet:

- dot plots
- pseudocolor plots (density plots)
- histogram plots
- spectral plots

To change the properties of a plot, right-click the plot and select Properties. You can select the plot type, parameters, scale, background color, and labels.

Plot Properties		Density Plot Options	
General		Density Levels:	<input type="text" value="15"/>
Plot Gate:	<input type="text" value="Tube_001_All Events"/>	Miscellaneous	
Plot Type:	<input type="text" value="Pseudocolor Plot"/>	Background Color:	<input type="text"/>
Parameters		<input type="checkbox"/> Include Plate Name	
X Axis Parameter:	<input type="text" value="FSC-A"/>	<input type="checkbox"/> Include Group Name	
X Axis Scale:	<input type="text" value="Linear"/>	<input checked="" type="checkbox"/> Include Tube Name	
Y Axis Parameter:	<input type="text" value="SSC-A"/>	<input checked="" type="checkbox"/> Include Population Name	
Y Axis Scale:	<input type="text" value="Linear"/>	<input type="checkbox"/> Include Custom Title	<input type="text"/>
Layout			
Width:	<input type="text" value="300"/>		
Height:	<input type="text" value="300"/>		

Gates

Gate types include:

- Rectangle
- Ellipse
- Polygon
- Interval
- Hinged Quadrants
- Staged Quadrants (select and drag an offset handle to move the quadrant segment up or down)
- Binary

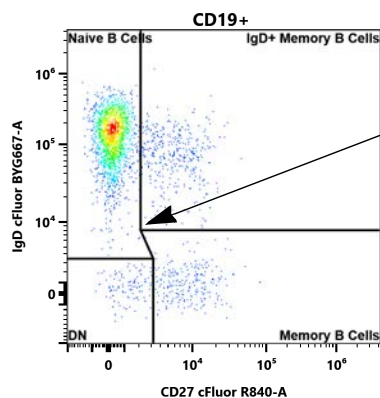

Gate Properties

Gate properties can be changed by right-clicking the gate. You can change the name of the gate, the color, and gate boundary line weight. You can also select whether to display the count and/or the % parent events within the gate, as well as the gate parameters.

Gate Properties

Gate Name:

Gate Color:

Count % Parent

Gate Boundary Line Weight:

Gate Borderline Color:

Parameters

X Axis Parameter:

Y Axis Parameter:

Boolean (Logical) Gates

Select multiple gates and right-click to open a menu to:

- Intersect the gates with the AND operator – events that are present in all of the selected gates are part of the intersected gate population.
- Join the gates with the OR operator – events that are present in at least one of the gates are part of the joined gate population. You can assign a new color for the joined gate or keep the original gate color (see “Gate Properties” on page 50).

Population Hierarchy Experiment_009-Group_001-Tube_001		
Population	% Parent	Count
▼ <input checked="" type="checkbox"/> All Events	N/A	N/A
▼ <input checked="" type="checkbox"/> P1	N/A	N/A
<input checked="" type="checkbox"/> P2	N/A	N/A
<input checked="" type="checkbox"/> P3	N/A	N/A

Delete Gate

Intersect (And) Gates

Join (Or) Gates

Bring to Front

Gate Properties

Statistics

To create a statistics box, click the Statistics icon in the worksheet toolbar, then click in the worksheet area.



Select the population checkbox next to the populations that have stats to display. To add a statistic, select the statistic from the Statistics Variable list.

Select the parameter you would like to add for the statistics. Multiple parameters can be selected at once.

The software offers a counts/ μ L statistic that can be calculated for any gate.

To adjust the precision of the statistics, select the decimal place in the Decimal Places table. To remove a statistic, right-click the column header and select Delete.

You can add keywords to statistics.

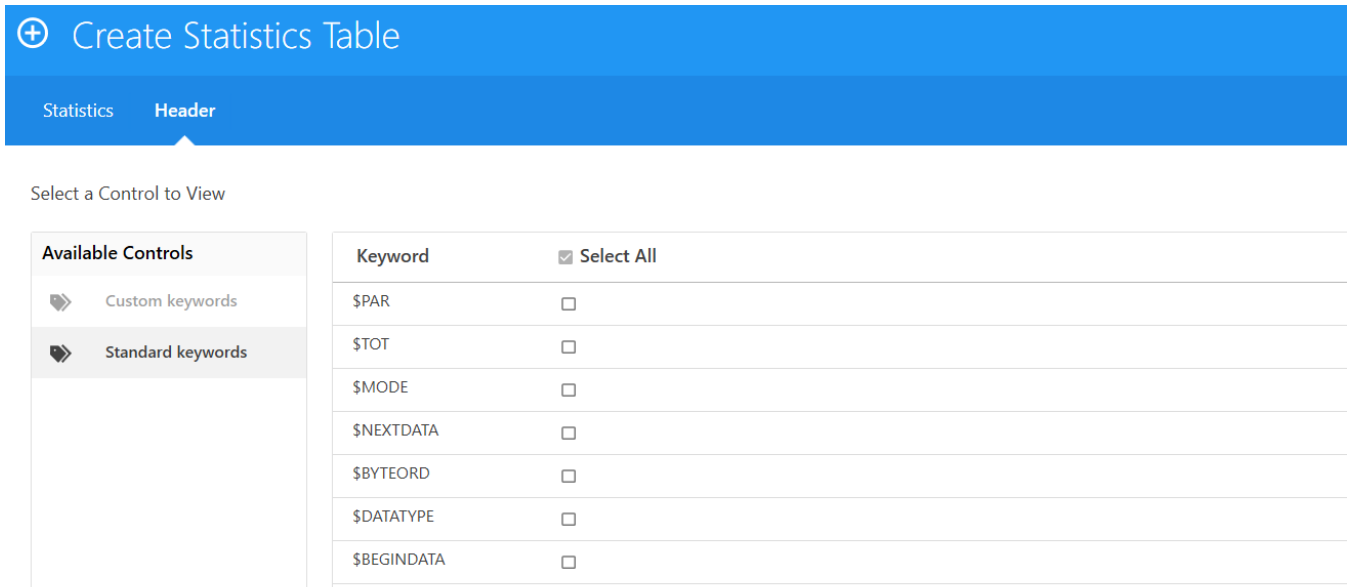

Once the statistics are complete, you can export the stats as a CSV file to the location you choose. Statistics output can be appended or overwritten if you export the stats into the same CSV file.

You can add keywords to the statistic table for exporting. Click the Header tab in the Create Statistics Table window and select the keywords to export.

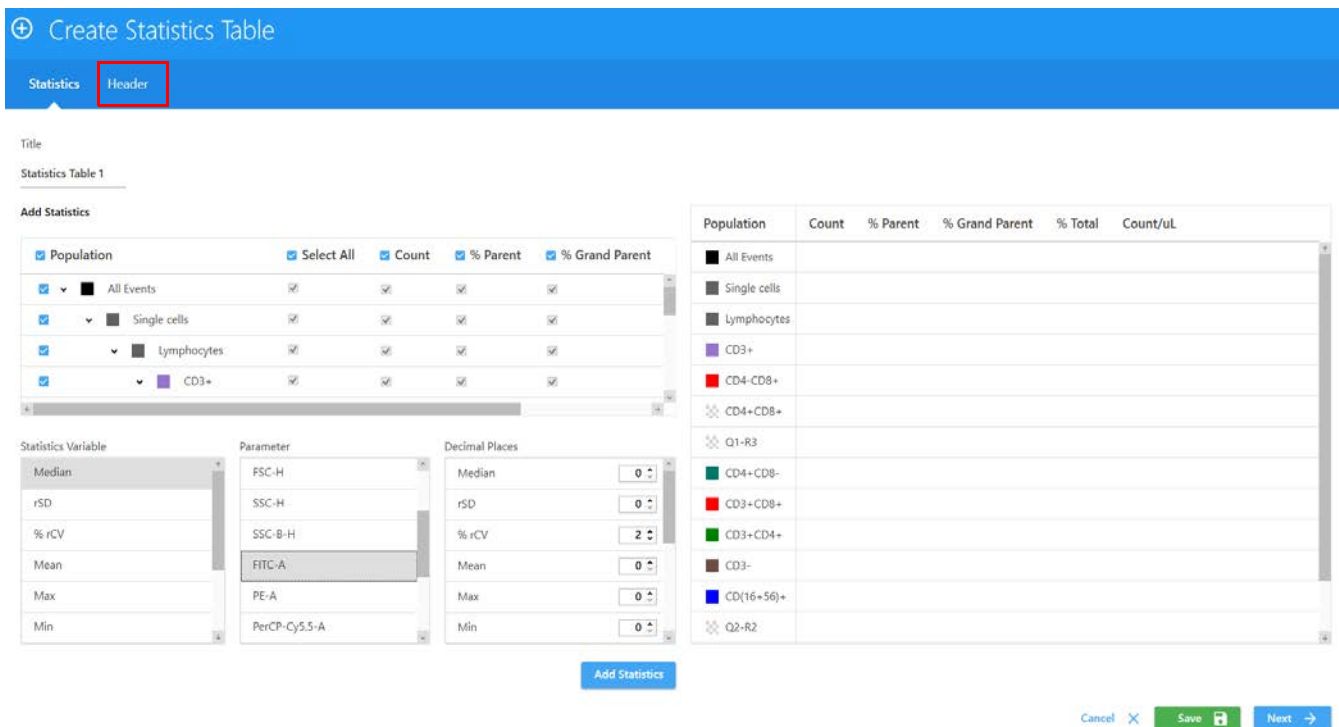

To export statistics from multiple tubes, select a group or multiple tubes, then right-click to select Batch Analysis. PDF and CSV files with data for multiple tubes can be exported.

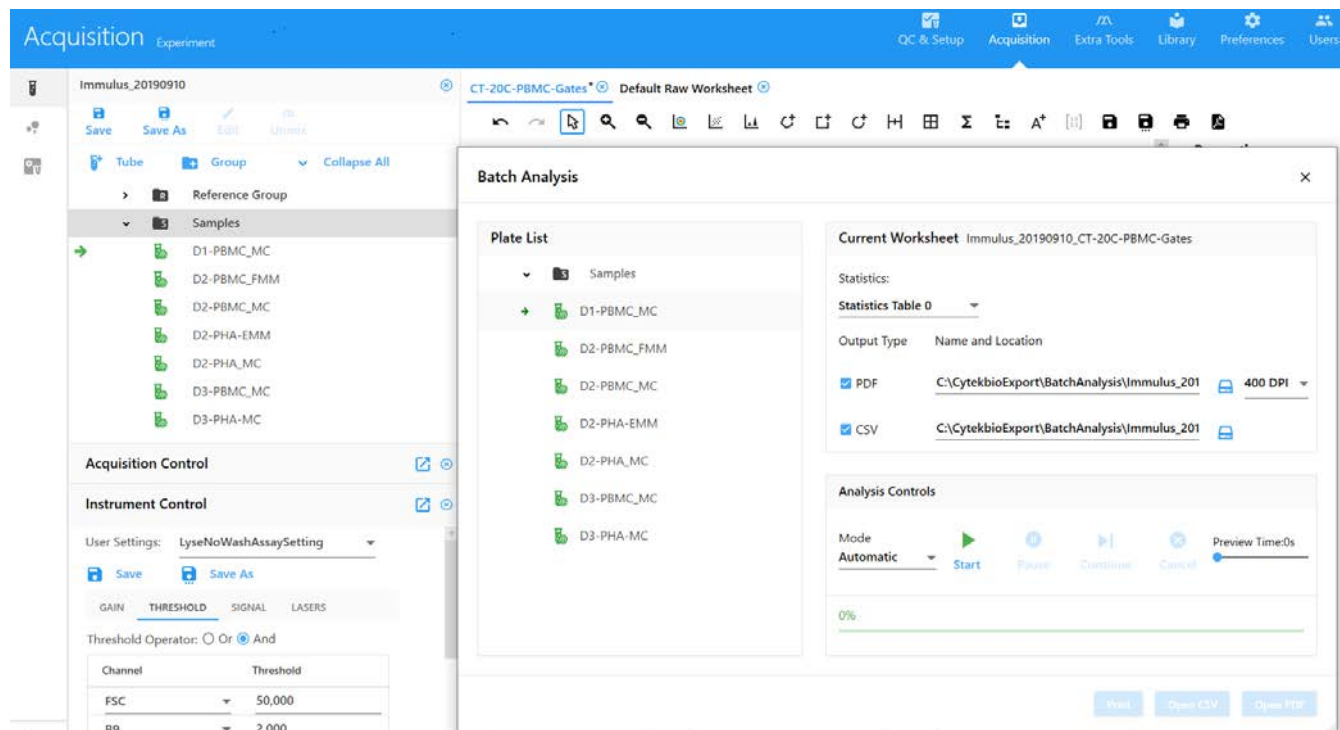

Creating a Default Experiment

Use the default experiment option to quickly begin an experiment. The default experiment contains a set of fluorescent tags, however, all parameters are user configurable.

- 1 Click Default in the Acquisition Experiment menu.

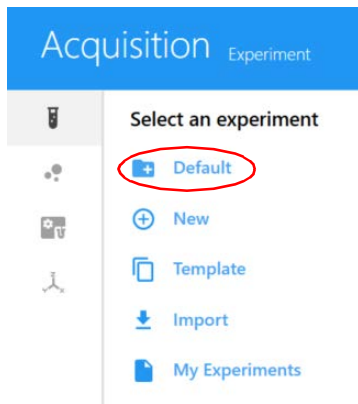

The default experiment opens with a default raw worksheet, plate/40 tube rack.

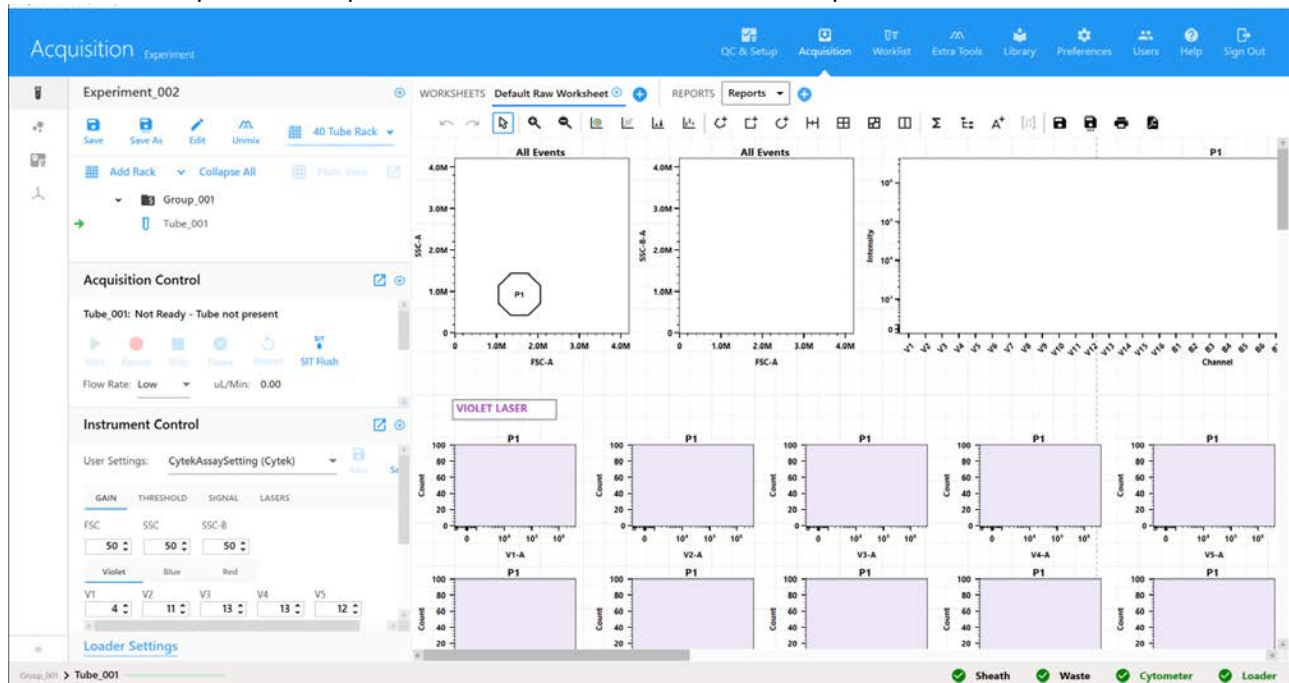

- 2 Choose carrier type.
- 3 Click Edit.

The same wizard appears as when creating a new experiment. Follow the steps to select the fluorescent tags, add groups, and define makers, keywords, and acquisition settings/worksheets.

See “Creating a New Experiment” on page 54 for details on defining the information in the experiment wizard.

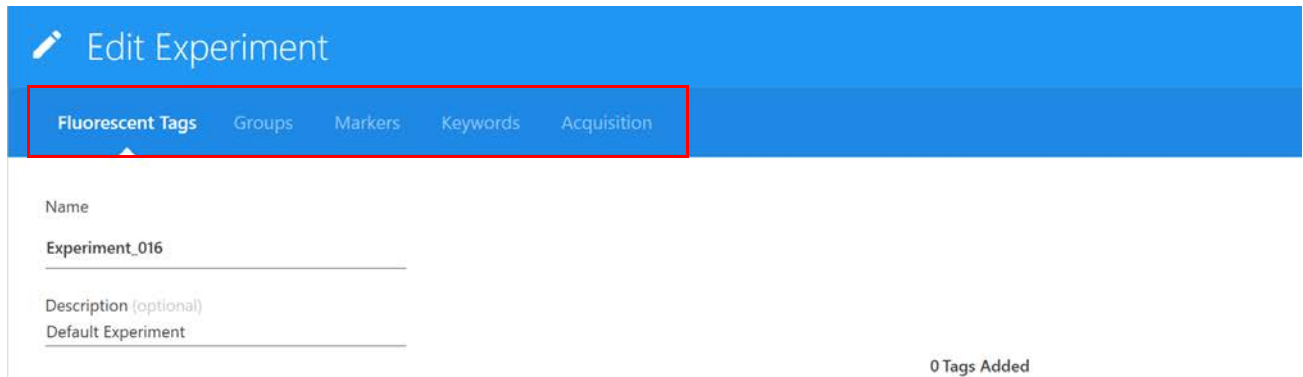

Creating a New Experiment

Selecting New in the Experiment menu opens the New Experiment wizard. The wizard walks you through the steps to create a new experiment.

- 1 Click New in the Acquisition Experiment menu.

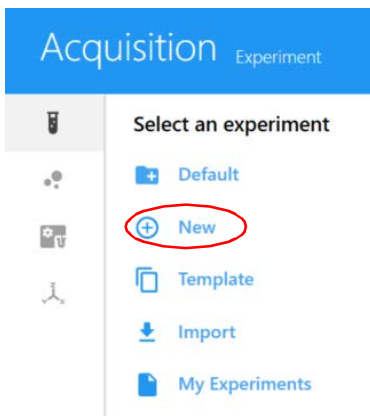

- 2 The Create New Experiment wizard opens. Specify a name for the experiment or use the default name. (Optional) Type in a description.

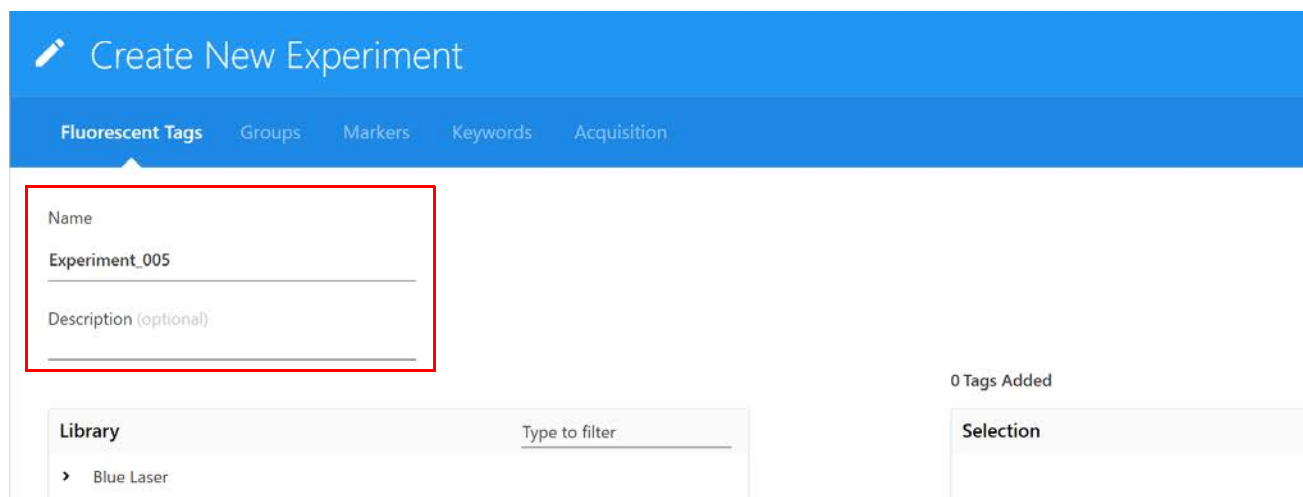

- 3 Click the arrow to the left of the group name (laser) in the Library pane on the left to display the list of its fluorescent tags. Select the fluorescent tags used in the experiment and click (+) Add to

add them to the Selection list on the right. You can also double-click the tag to add it to the Selection list.

To quickly find a fluorescent tag, type the tag name in the Type to filter text box. A default list of fluorescent tags for each group is available in the library. See “Fluorescent Tags” on page 63.

You must select all fluorescent tags present in the experiment, as this will determine which reference controls are to be used during spectral unmixing.

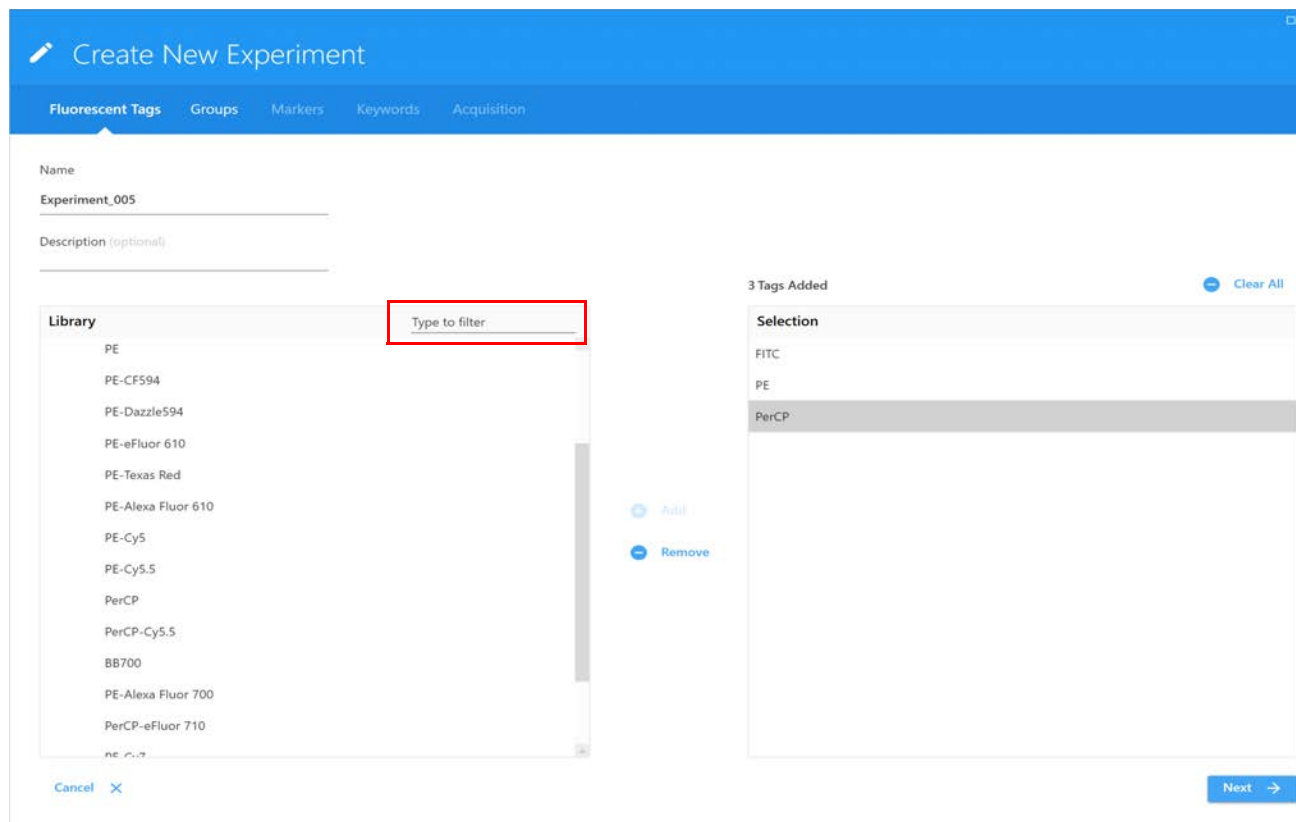

To remove individual fluorescent tags from the Selection list, click to select the tag, then click Remove. To remove all fluorescent tags, click Clear All.

- 4 Once all fluorescent tags have been chosen from the Library list, confirm the list in the selection pane, then click Next.
- 5 Ensure the correct Carrier Type (Manual Tube), plate, 40 tube rack, or plate type is selected, then create groups for your samples by selecting **+ Group**. Add tubes to the groups, plate, or 40 tube rack.

- 6 Create groups for your samples by selecting  Group. Add tubes to the groups.

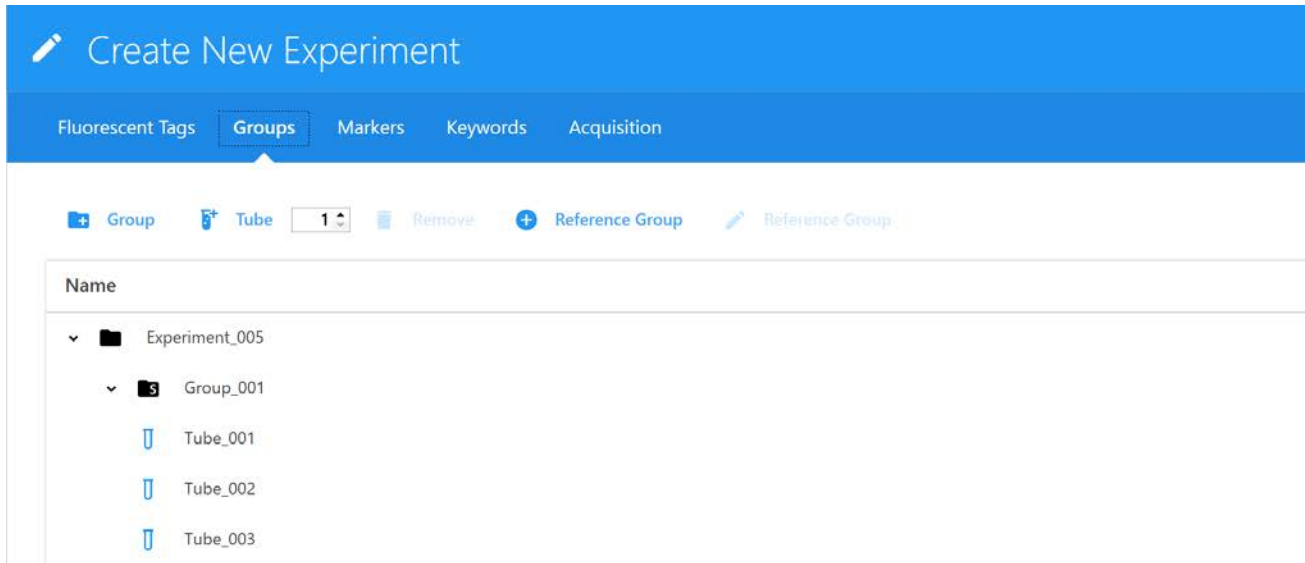

- 7 Select  Reference Group if you are intending to unmix with all or some controls acquired in this experiment.

This creates a list of reference control tubes for each fluorescent tag specified as part of the experiment.

■ **NOTE:** If you plan to unmix the samples using only reference controls run in QC & Setup, step 7 is not necessary.

■ **NOTE:** When using controls from the reference library and running controls live, you will delete the controls to be used from the library and run the other controls. When unmixing, you will add the controls from the library to unmix all the controls.

- 8 **IMPORTANT:** Define an unstained control for autofluorescence by selecting its control type (beads or cells). The unstained control needs to be of the same type and prepared in the same way as the samples, as this will ensure accurate unmixing and autofluorescence quantitation.

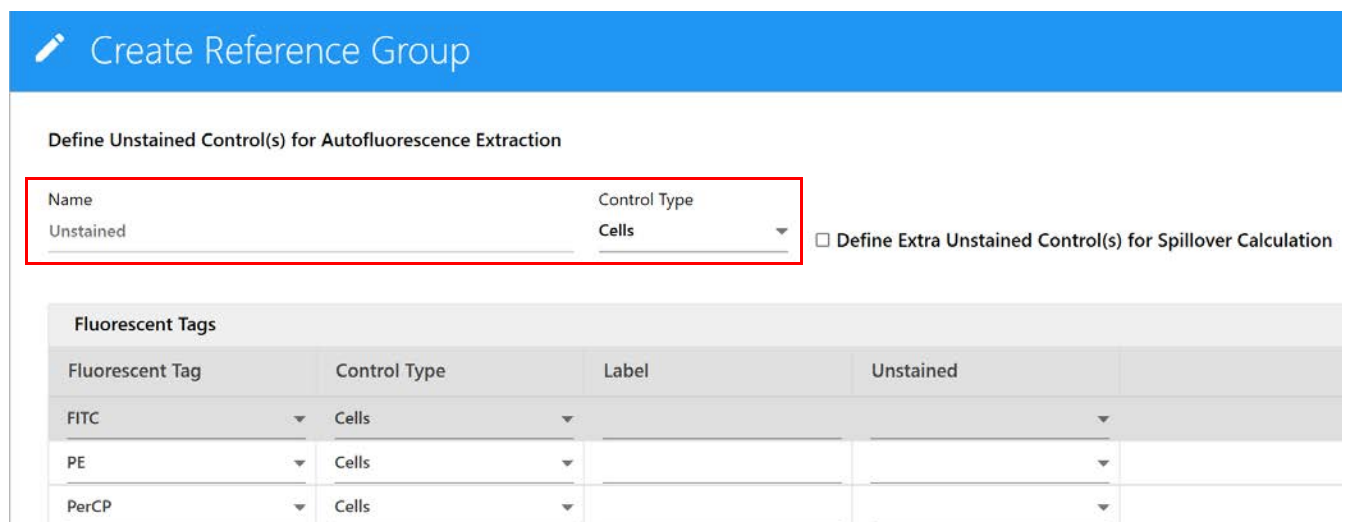

- If applicable, select Define Extra Unstained Control(s) for Spillover Calculation to use a different unstained control to calculate spillover for your reference controls. Then enter a name and control type for this extra unstained control.

For example, if test samples are cells and the reference controls are beads, all with only positive peaks, you will need to run a separate tube of negative beads for the spillover calculation. An extra unstained control is not needed if your unstained autofluorescence control (and sample) is the same type as the reference controls.

- Select the control type (beads or cells) for the single-stained reference controls.
- (Optional) Enter the label (for example, CD nomenclature) that is conjugated to the fluorescent tag.
- If applicable, enter the lot number(s) of the reference controls.

■ **NOTE:** If you selected Label/Lot Specific Unmixing in the Acquisition Preferences (see [page 72](#)), the software will search the library and experiment reference groups for reference controls that have the same fluorescent tag, label, and lot information in order to use the corresponding control for unmixing.

■ **NOTE:** Use the red trash can icon to delete an individual tube from the reference group. This may be necessary if you wish to mix and match references acquired in this experiment with reference controls run in QC & Setup. Any stored controls you plan to use should be deleted from the reference group.

13 Click Save.

Once the reference group has been created, entries for each of the references will be displayed. Each of the reference group tubes will have an icon (with the letter R) associated with it under the reference group.

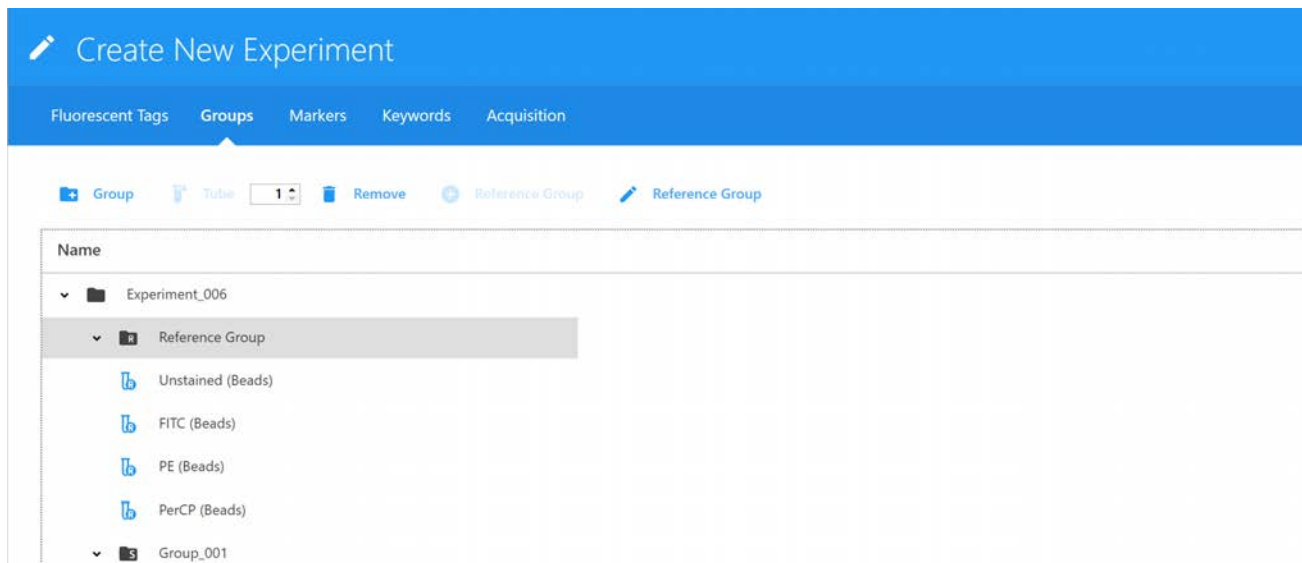

14 If necessary, continue adding tubes, click Next when all tubes are created.

15 Add markers/labels to the remaining sample tubes before continuing. They can be chosen from the Labels list on the right, typed directly into the table, or copied and pasted. Labels can be added at the group or tube level and can be applied to multiple cells selected at once. Labels are required for reference controls if you selected Label/Lot Specific Unmixing in the Acquisition Preferences (see [page 72](#)). Click Next when all the tubes are labeled.

■ **NOTE:** If you selected Label/Lot Specific Unmixing, the software will search the library and experiment reference groups for reference controls that have the same fluorescent tag, label, and lot information in order to use the corresponding control for unmixing.

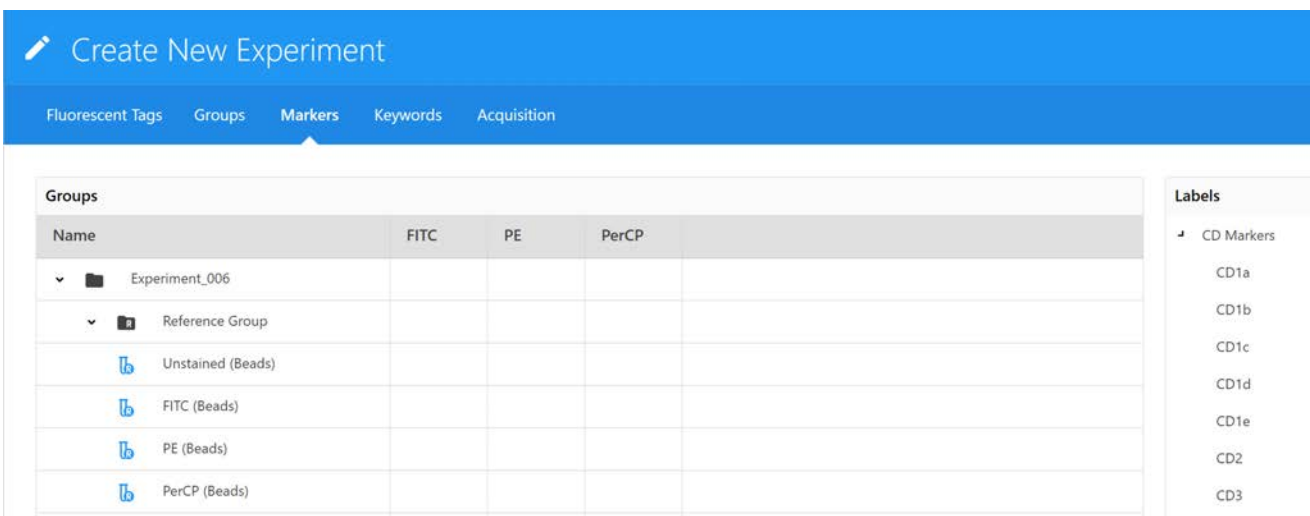

16 (Optional) Enter custom keywords and click Next.

Custom keywords can be added at the experiment, group, or tube level. You must define the custom keywords in the Library before you can add them to an experiment (see [“Keywords” on](#)

page 65 for information). Drag and drop the keywords from the Keywords list on the right to the experiment, group, or tube and enter keyword values as needed. You can also copy and paste custom keywords across different tubes in this wizard.

The screenshot shows the 'Edit Experiment' interface with the 'Keywords' tab selected. The interface is divided into a main table and a side panel.

Main Table:

Name	Keyword	Value	Keyword	Value	Keyword	Value	Keyword
Test-Keywords							
Reference Group							
Setup							
Samples							
WB1	Sample ID	A01	Patient Name	ABC	Age	25	
WB2	Sample ID	A02	Patient Name	XYZ	Age	46	

Keywords List (Right Panel):

- Subject ID
- LymphSet 6C
- Sample ID
- Patient Name
- Age

17 Select the acquisition settings and worksheet(s). The worksheet menu lists all the worksheets for the given user.

- Select the Default Raw Worksheet (Raw) for the Reference Group and for the sample groups if you plan to perform post-acquisition unmixing.
- Select the Default Unmixed Worksheet (Unmixed) or any user-created unmixed worksheet for your sample groups if you are performing live unmixing. Worksheets can be selected at the experiment, group, or tube level.

Select the stopping gate, storage gate, number of events to record, Stopping volume (μL), Stopping Criteria, Stopping Time (seconds). Acquisition stops when the first of the stopping criteria is met (time, volume, number of events). These criteria can be selected at the experiment, group, or individual level.

- If acquiring beads, we recommend collecting 5,000 singlet events.
- If acquiring cells, we recommend collecting 10,000 to 20,000 events of the desired population.

■ **NOTE:** The number of events to acquire depends on the target population. For example, you may need to acquire 10,000 to 20,000 events to get 2,000 of the desired population. Approximately 1,000 to 2,000 events is needed in both the negative and positive populations of each control for accurate unmixing.

- 18 Select Tube/Well Specific User Settings if you want to apply specific user settings to individual tubes/well. If left unchecked, all tubes/wells in the experiment will use the same experiment user settings.

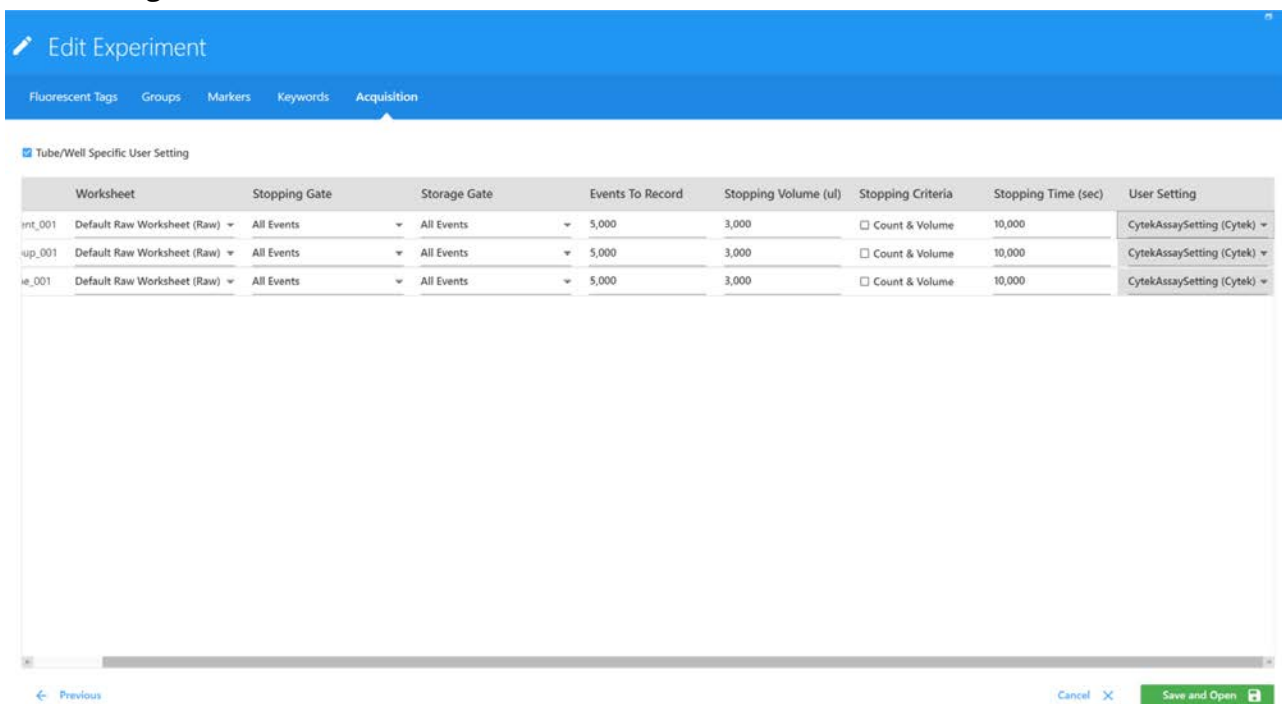

- 19 Once the worksheet and stopping criteria have been defined, click Save and Open to open the new experiment.

To make any changes to the experiment, click Edit above the group/tube hierarchy.

- 20 To acquire controls and samples and perform live unmixing, see “Live Unmixing” on page 92.

Creating an Assay

Create New Assays

Assay components

An Assay is similar to an experiment template, but is formatted to be used in a Worklist for batch sample data collection. An assay includes the following elements: tube(s) (one or more tubes), fluorescence tags, marker labels, worksheet(s) (optional), report(s) (at least one), preview time, data collection stopping rules, Carrier type, and Keywords

Create Reports

Experiments can be saved as Assays. An assay needs to contain at least one report.

- 1 Click the plus sign to the right of REPORTS on the experiment toolbar to create a report.

2 Double-click the corresponding Report to edit the report name.



3 Click on report.

You can edit the report and add elements such as plots, gates, statistics, header and footer information. Adding worksheet elements to the report is done by copying from the worksheet desired and pasting into the report.

4 Copy the desired plots and gating hierarchy from the worksheet and paste in the report.

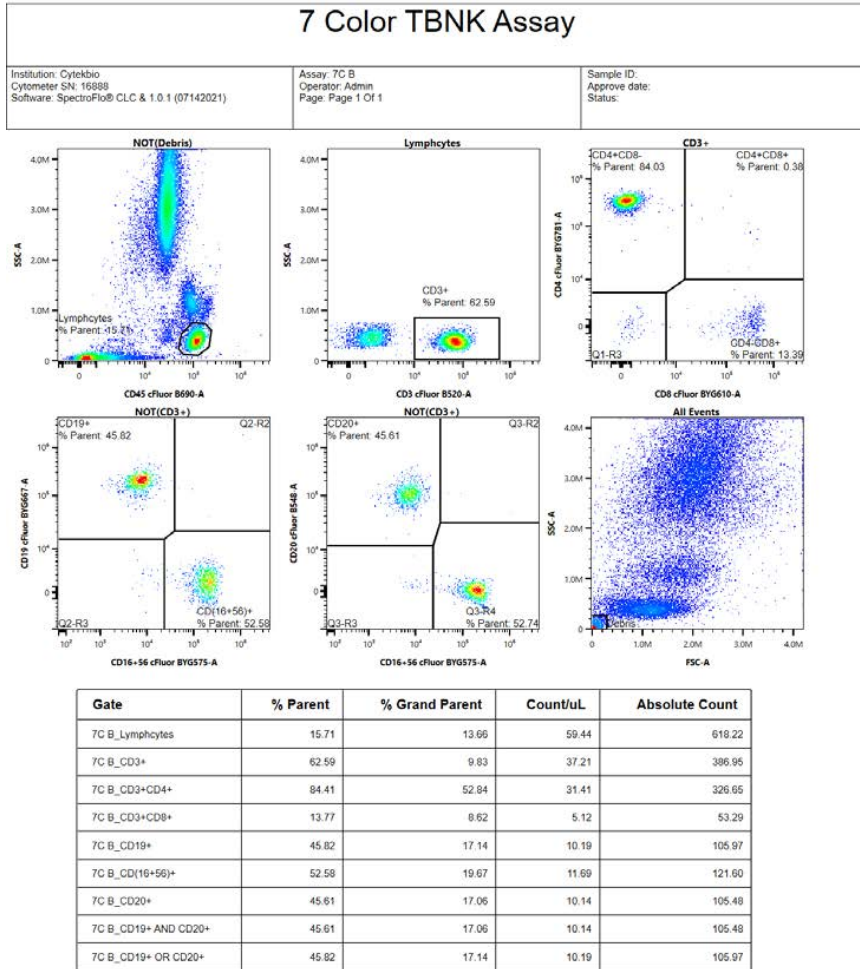

Signature:

REPORT NOT SIGNED

Comments:

■ NOTE: Report vs. Worksheet

- The Report is a static data display sheet that can display the data from one or more tubes.
- The Worksheet is a dynamic data display sheet, which displays the data in the current tube with tube point pointed to it and can only display the data from one tube at a time.

5 Add Header, Footer, and Signature in Report.

- Select the header, footer, and signature icon buttons on the toolbar to add headers, footers and signature boxes to the report.
- Enter relevant information in the header and footer as needed, such as the name of the report, company logo, etc.



- 6 Right-click in the header or footer on the Report to select the information from a dropdown list to display, such as Sample ID, Operator, Data recording date, etc.

7 Color TBNK Assay				
Institution: Cylekbio Cytometer SN: 16898 Software: SpectroFlo® CLC & 1.0.1 (07142021)		Assay: 7C B Operator: Admin Page: Page 1 Of 1		Sample ID: Approve date: Status:
Gate	% Parent	% Grand Parent	Count/uL	Absolute Count
7C B_Lymphocytes	15.71	13.66	59.44	618.22
7C B_CD3+	62.59	9.83	37.21	386.95
7C B_CD3+CD4+	84.41	52.84	31.41	326.65
7C B_CD3+CD8+	13.77	8.62	5.12	53.29
7C B_CD19+	45.82	17.14	10.19	105.97
7C B_CD(16+56)+	52.58	19.67	11.69	121.60
7C B_CD20+	45.61	17.06	10.14	105.48
7C B_CD19+ AND CD20+	45.61	17.06	10.14	105.48
7C B_CD19+ OR CD20+	45.82	17.14	10.19	105.97

Save an experiment as an assay

Users with proper privileges can use Save As-Assay to convert an experiment into an assay template (Assay), which can be used in the Worklist.

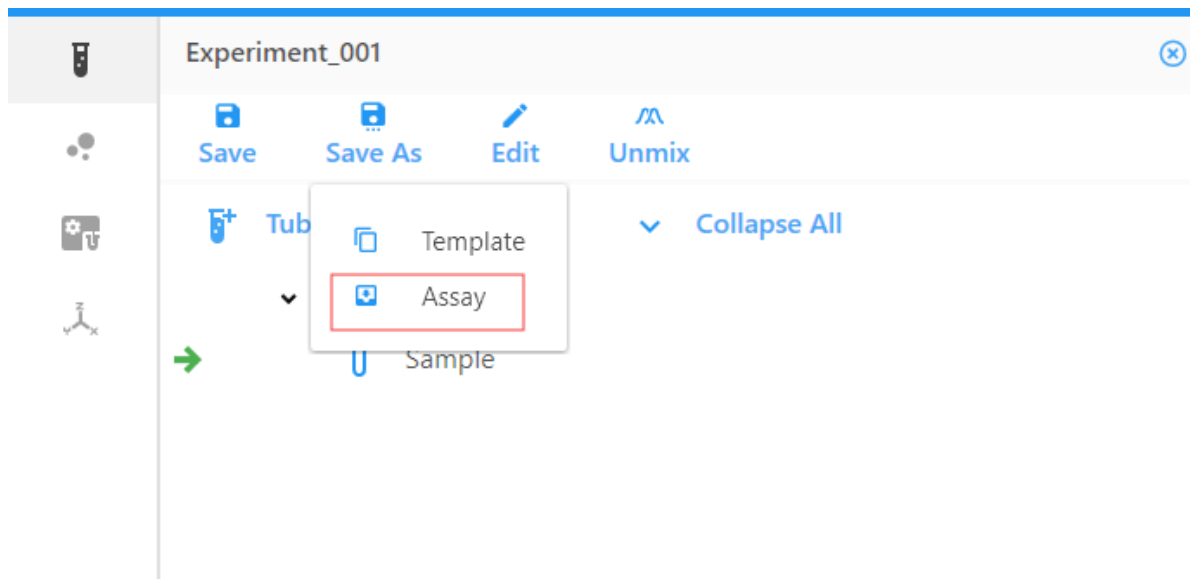

Library, Preferences, and Users

Library

The library contains information for various elements used for the experiments. Information saved in the library includes SpectroFlo QC bead lots, fluorescent tags, labels, user settings, worksheet templates, experiment templates, and keywords. Information stored in the library can be saved, exported, and imported for reuse.

QC Beads

SpectroFlo QC bead lot IDs and expiration dates can be imported, exported, or removed from the library. The QC bead lot for the beads used for Daily QC must be saved in the library. Select QC Beads to see a list of QC bead lots.

Library QC Beads	
QC Beads	
Import Export Remove	
Lot ID	Expiration Date
1002	December 31, 2021
1001	December 31, 2020

Fluorescent Tags

Fluorescent tags are the designation given to each distinct fluorescent molecule that can be detected by the system. This includes for example, fluorophores, fluorescent proteins, and fluorescent viability dyes. Each unique fluorophore run on the instrument must be given a fluorescent tag name.

By default, several groups of fluorescent tags are pre-installed with the software—Blue Laser, Red Laser, Violet Laser, Fluorescent Proteins, and Viability Dyes. These groups contain the most

commonly used fluorophores excited by the system's on-board lasers. Additional tags can be added to these groups.

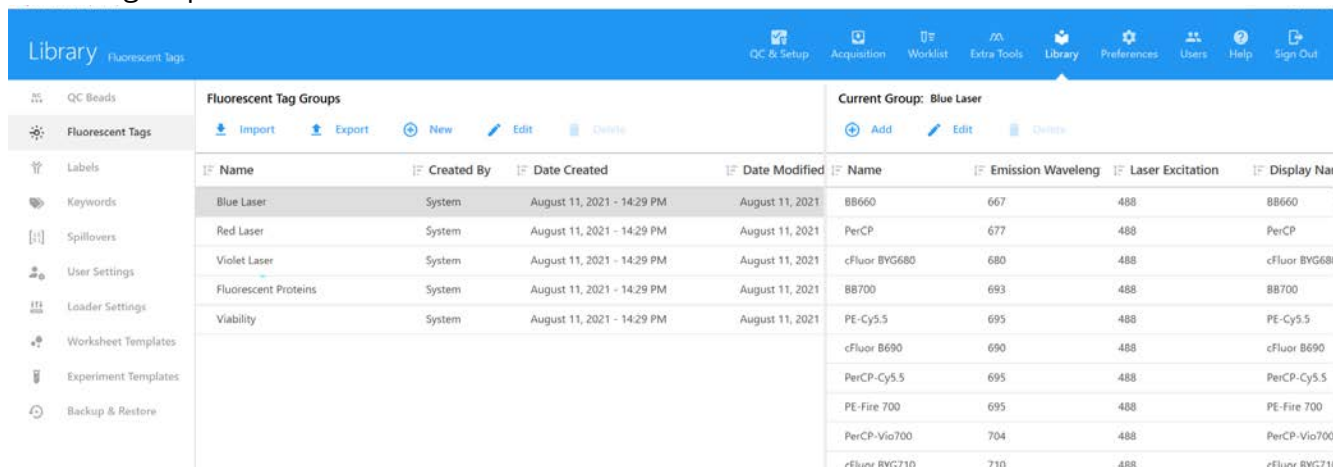

You can create groups or individual fluorescent tags by selecting Add. Both groups and individual fluorescent tags can be imported or exported.

■ **NOTE:** Selecting New will create a new group while selecting Add will allow you to add an individual fluorescent tag to a group.

To edit the properties of a fluorescent tag that you added, select the fluorescent tag of interest and select Edit. Properties that can be edited include fluorescent tag name, laser excitation wavelength, emission wavelength, and display name. The default tags that are included with the software cannot be edited or deleted. However, they can be exported and imported across different systems running SpectroFlo software, v2.2.

If the fluorophore is known by another name or identified by a different spelling, those additional names or spellings can be added as synonyms.

Any groups that you created can also be edited in this window. The default groups cannot be edited or deleted.

Labels

Fluorescent tags can be conjugated or attached to proteins that can specifically bind to other proteins on the cell surface or within the cytoplasm. They can also be inherently fluorescent, such as fluorescent proteins that can be fused to a variety of cellular proteins using molecular cloning techniques. The proteins that are either bound or attached to fluorescent tags can be designated as labels. The software comes with an initial set of pre-installed labels that are categorized as CD

Markers, Chemokines, Chemokine Receptors, and Cytokines. Additional labels can be added by using **+** Add in the right pane.

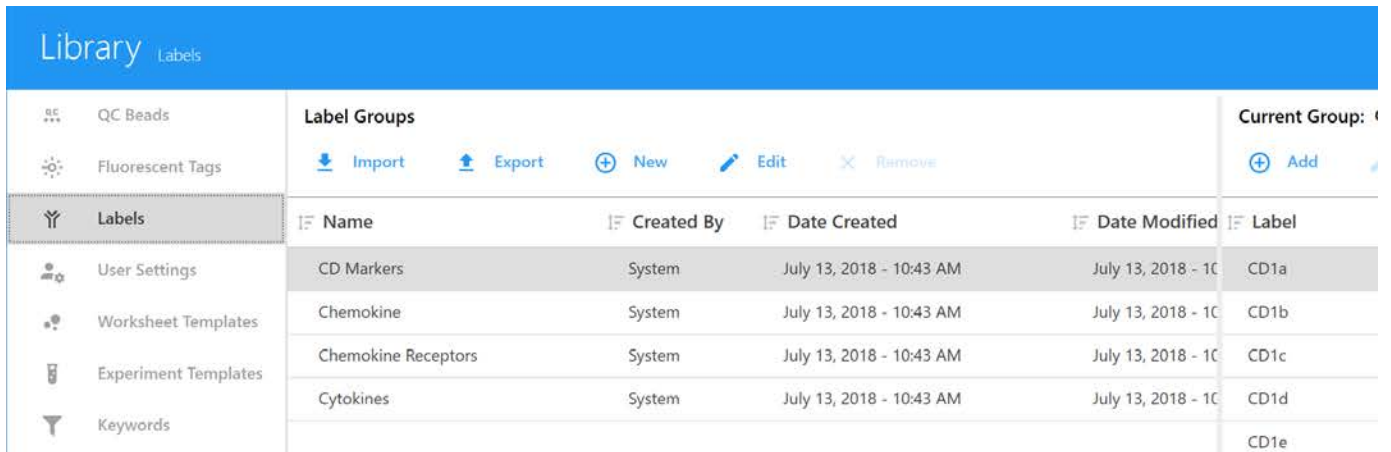

The screenshot shows the 'Library Labels' interface. On the left is a sidebar with navigation options: QC Beads, Fluorescent Tags, Labels (selected), User Settings, Worksheet Templates, Experiment Templates, and Keywords. The main area is titled 'Label Groups' and contains a table with columns: Name, Created By, Date Created, Date Modified, and Label. Below the table are buttons for Import, Export, New, Edit, and Remove. On the right, there is a 'Current Group:' section with an 'Add' button.

Name	Created By	Date Created	Date Modified	Label
CD Markers	System	July 13, 2018 - 10:43 AM	July 13, 2018 - 10:43 AM	CD1a
Chemokine	System	July 13, 2018 - 10:43 AM	July 13, 2018 - 10:43 AM	CD1b
Chemokine Receptors	System	July 13, 2018 - 10:43 AM	July 13, 2018 - 10:43 AM	CD1c
Cytokines	System	July 13, 2018 - 10:43 AM	July 13, 2018 - 10:43 AM	CD1d
				CD1e

New label groups and individual labels can be created by clicking New. Label groups can also be imported and exported for use on other systems. The default labels cannot be edited or deleted.

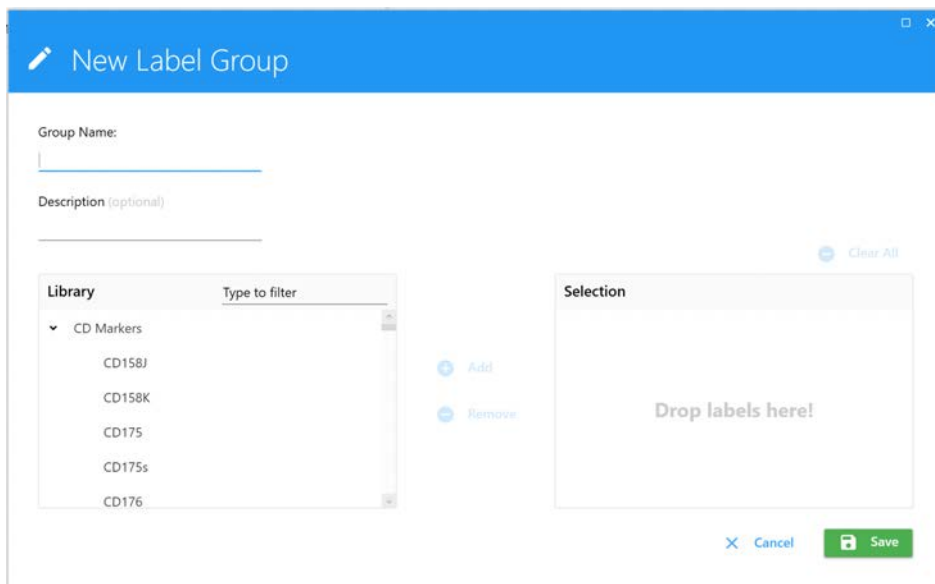

The 'New Label Group' dialog box has a blue header with a pencil icon and the title 'New Label Group'. It contains a 'Group Name:' text input field, a 'Description (optional)' text input field, and a 'Clear All' button. Below these is a 'Library' section with a search bar 'Type to filter' and a list of labels under 'CD Markers': CD158J, CD158K, CD175, CD175s, and CD176. There are 'Add' and 'Remove' buttons between the library and a 'Selection' area. The 'Selection' area is empty and contains the text 'Drop labels here!'. At the bottom are 'Cancel' and 'Save' buttons.

Keywords

Keywords allows you to type, import, or export user-defined, custom FCS keywords by group. These keywords can be assigned in an experiment at the experiment, group, or tube level and are exported with the FCS files.

The following types of keywords can be created:

- Numeric
- String
- Boolean
- Selectable numeric

- Selectable string

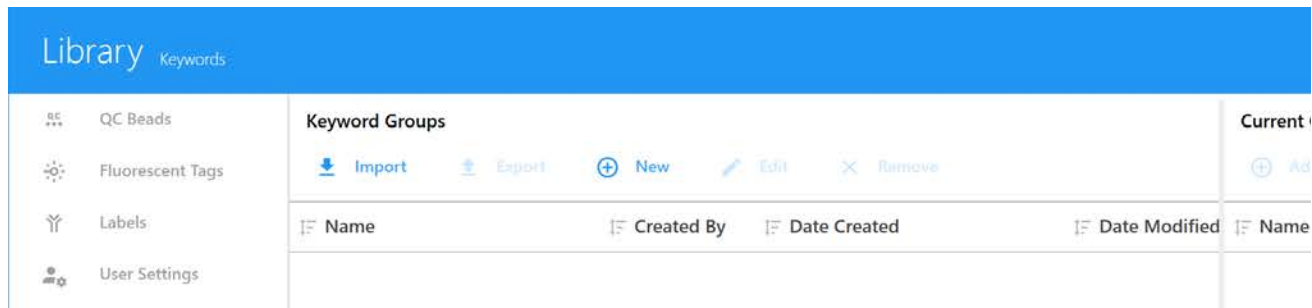

Standard Keywords

The following table describes the standard FCS 3.1 keywords found in SpectroFlo FCS files.

Keyword	Description
\$FIL	Tube name
\$VOL	Total sample volume (microliters)
\$DATE	Date that the FCS data set was acquired
\$BTIM	Beginning time of data acquisition
\$ETIM	End time of data acquisition
\$OP	Operator name
\$INST	Institution name
\$CYT	Name of cytometer (Northern Lights)
\$CYTSN	Cytometer serial number
\$SPILLOVER	Spillover matrix

Custom Keywords

The following table describes the custom keywords found in SpectroFlo FCS files. Custom keywords are not required as part of the FCS 3.1 standard.

Keyword	Description
APPLY COMPENSATION	True or False to indicate whether compensation is enabled when FCS file is loaded into SpectroFlo
CHARSET	Encoding. UTF8.
CREATOR	Software name and version
FSC ASF	FSC area scaling factor
GROUPNAME	Name of sample group
LASER{x}NAME	Name for each laser
LASER{x}DELAY	Laser delay for each laser

Keyword	Description
LASER{x}ASF	Area scaling factor for each laser
P{x}DISPLAY	Preferred display scale
THRESHOLD	Threshold channel and value
TUBENAME	Name of sample tube
WINDOW EXTENSION	Window extension used to record the tube
USERSETTINGNAME	User setting name used to record the tube

Users can change the value of a custom keyword, then select Auto Update for that keyword to update the keyword in subsequent experiments.

The screenshot shows the 'Library Keywords' interface. On the left is a navigation menu with 'Keywords' selected. The main area is divided into 'Keyword Groups' and 'Current Group: Default Keywords'. The 'Current Group' table has columns: Name, Suffix, Type, Value, Auto Update, and Description. A red box highlights the 'Auto Update' checkboxes for 'Age', 'Sample Type', 'Gender', and 'Dilution Factor'.

Name	Suffix	Type	Value	Auto Update	Description
Age		Numeric	0	<input type="checkbox"/>	
Sample Type		String		<input type="checkbox"/>	
Gender		Selectable String	M	<input type="checkbox"/>	
Dilution Factor		Numeric	1.00	<input type="checkbox"/>	

Spillovers

Spillovers shows the spillover matrices saved during experiments. These saved matrices can be used for other experiments.

The screenshot shows the 'Library Spillovers' interface. The left navigation menu has 'Spillovers' highlighted with a red box. The main area is titled 'Spillover Matrix' and contains a table with columns: Name, Created By, Date Created, and Description.

Name	Created By	Date Created	Description

User Settings

User Settings are the set of gain settings, threshold, and signal type for all detector channels. The date when it was created, as well as the name of user who created it are also saved. The settings are saved from the Instrument Control Pane in the Acquisition module. The name and description can be modified in this tab. Administrators can check the Shared checkbox to allow all user to see

and use the settings and worksheets created by other users. These settings can be saved from the Acquisition screen.

If you wish to reset the system-defined Default user settings to their original settings, select the Default user setting, then click Restore Default.

Name	Created By	Date Created	Description
CytekAssaySetting	Admin	August 15, 2018 - 10:14 AM	Cytek Assay Setting
Default	Admin	August 15, 2018 - 10:14 AM	Default

Loader Settings

Loader settings can be saved and are stored in the library. The settings name, date the settings were created, version, as well as the name of user who created them are displayed. Click Description to add information about the settings.

Loader settings include mix time and speed, sample return, number of SIT flushes, and record data delay time.

Name	Created By	Date Created	Version	Description
------	------------	--------------	---------	-------------

Worksheet Templates

All worksheets created in the Acquisition module are saved in the library and can be accessed through the Worksheet Templates tab. Worksheets can be exported as WTML files and imported for re-use. For more information on worksheets, see [“About Worksheets” on page 21](#).

Select a user(s) to view the worksheet templates created by that user(s). Click the pen tool to edit the description of the selected worksheet. Administrators can check the Shared checkbox to allow all users to see and use the worksheet templates created by other users. SuperUsers can view, import, and export worksheet templates, but cannot delete templates created by other users.

To view a worksheet, select it, then click View. To remove a worksheet that is no longer needed, select it, then click Remove.

You can also set the default raw and unmixed worksheets back to their original defaults by selecting the worksheet, then clicking Restore Default.

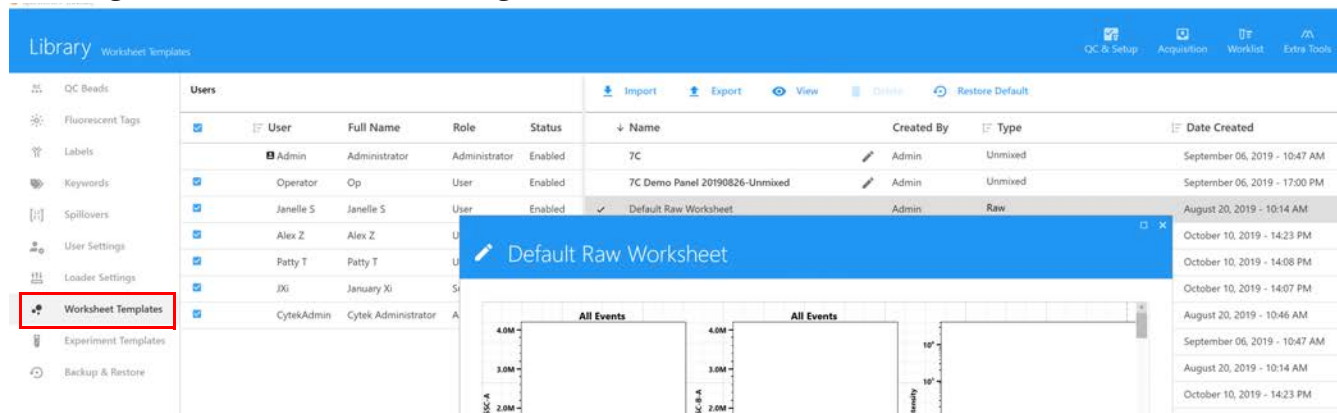

Experiment Templates

Experiment templates contain the key elements of an experiment without the data. They can be saved and stored in the library for future use. Saved Assays are displayed in the assay tab. The name, creation date and time, description, and creator information is displayed. Experiment templates can also be imported and exported from this tab. Assays can be used to create experiments. For more information on experiments, see [“About Experiments” on page 18](#).

Select a user(s) to view the experiment templates created by that user(s). Click the pen tool to edit the description of the selected worksheet. Administrators can check the Shared checkbox to allow all users to see and use the experiment templates created by other users. SuperUsers can view, import, and export experiment templates, but cannot delete templates created by other users. To delete an experiment template that is no longer needed, select it, then click Delete. The default experiment template cannot be deleted.

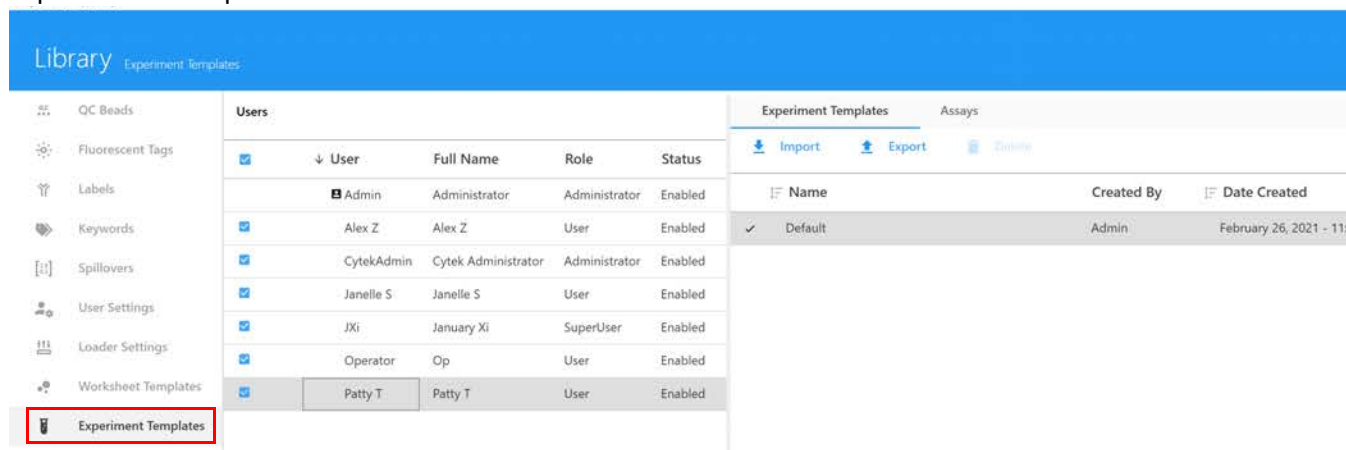

Backup & Restore

Users and SuperUsers can back up selected data from their accounts directly from SpectroFlo software. This includes experiments, experiment templates, worksheets, user settings, Loader settings, daily QC results, and reference controls. Administrators have the additional ability to back up selected data from the different User and SuperUser accounts.

- 1 To back up data, click Backup in the right pane.

2 Choose a timeframe (day, week, month, or custom timeframe) that includes the data, select the user(s).

The screenshot shows the 'Library Backup & Restore' interface. The left sidebar contains a list of options, with 'Backup & Restore' highlighted by a red box. The main area is divided into several sections:

- Navigation:** 'Backup' and 'Restore' buttons.
- Timeframe Selection:** 'Day', 'Week', 'Month', and 'Custom' tabs. The 'Day' tab is selected.
- Filters:** 'Start: 3/2/2021' and 'End: 3/2/2021'.
- Buttons:** 'Backup' (green) and 'Erase' (red).
- User Table:** A table with columns 'User', 'Full Name', and 'Role'. The 'Admin' user is selected.
- Data Selection:** A list of data items with checkboxes, including 'Data', 'Experiments', 'Experiment Templates/Assays', 'Worklists', 'Worksheets', 'User Settings', 'Loader Settings', 'Daily QC Results', and 'Reference Controls'.

User	Full Name	Role
<input checked="" type="checkbox"/>	Admin	Administrator
<input type="checkbox"/>	Operator	Op
<input type="checkbox"/>	Janelle S	User
<input type="checkbox"/>	Alex Z	User
<input type="checkbox"/>	Patty T	User
<input type="checkbox"/>	JXi	SuperUser
<input type="checkbox"/>	CytekAdmin	Cytek Administrator

<input checked="" type="checkbox"/>	Data
<input checked="" type="checkbox"/>	Experiments
<input checked="" type="checkbox"/>	Experiment Templates/Assays
<input checked="" type="checkbox"/>	Worklists
<input checked="" type="checkbox"/>	Worksheets
<input checked="" type="checkbox"/>	User Settings
<input checked="" type="checkbox"/>	Loader Settings
<input checked="" type="checkbox"/>	Daily QC Results
<input checked="" type="checkbox"/>	Reference Controls

Preferences

The Preferences module allows you to change various functionality and display elements of the software user interface. The following section describes the options that can be changed in the Preferences module. Each section within the Preferences can be restored to its default settings by selecting Restore Default Preferences.



Restore Default Preferences

Acquisition Preferences

In the Acquisition tab, you can change the number of events displayed on plots during acquisition, the number of SIT flushes, the preview time before recording begins, the value that the gain settings increment when you click the spin-box arrow during acquisition, and the SIT Lift Distance. You can also enter default prefixes for tube, group, and experiment names. A label/lot specific unmixing feature allows you to choose specific reference controls for unmixing. The Batch Analysis options allow you to choose the output file type and tube/well results contained in the PDF.

Preferences Acquisition

- Acquisition
 - Number of Events to Display on Plots: 2,000
 - Number of Automatic SIT Flush After Tube Unload: 1
 - Data Review Time(Sec) After Tube Recorded: 0
 - Record Data Delay Time(Sec) for Manual Tube: 0
 - Gain Spinbox Up/Down Increment (Ctrl key Held): 5
- Experiment**
 - Default Tube Name Start With: Tube_
 - Default Group Name Start With: Group_
 - Default Plate Name Start With: Plate_
 - Default Tube Rack Name Start With: TubeRack_
 - Default Experiment Name Start With: Experiment_
 - Default User Setting: CytekAssaySetting (Cytek)
 - Ref Controls Ordered by Control Type
- Unmixing Feature**
 - Label/Lot Specific Unmixing
 - Preferred SSC Channel for Unmixing: SSC
- Batch Analysis**
 - Default Output File Type: PDF CSV
 - Default PDF File Option: All in one file Each tube/well has its own file

The following table describes the options in the Acquisition preferences.

Item	Description
Number of Events to Display on Plots	The number of events displayed in the pseudocolor plots, dot plots, and histograms. The default is 2,000 events.
Number of Automatic SIT Flush After Tube Unload	Choose the number (0-2) of SIT Flushes that will be performed once a tube is removed from the SIP.
Data Review Time (Sec) After Tube Recorded	The number of seconds that elapse before the tube pointer moves to the next tube after the current tube is finished recording.
Record Data Delay Time (Sec) for Manual Tube	The number of seconds before it begins recording after you click Record.
Gain Spinbox Up/Down Increment (Ctrl key Held)	Increments the gain for each detector channel by the amount indicated when you hold the Ctrl key and select the up and down arrows of the Gain spinbox.
Experiment	<p>Enter the default name for tubes, groups, plates, tube racks (ASL only), and experiments. Edit the default name and/or append to the existing names.</p> <p>Select the default user settings for experiments.</p> <p>Ref Controls Ordered by Control Type allows you to order reference controls by type (beads or cells). If unchecked, reference controls are ordered by excitation laser, then by peak emission.</p>
Unmixing Feature	<p>Label/Lot Specific Unmixing allows you to use lot-specific reference controls for unmixing when appropriate. If this option is selected, the software will search the library and experiment reference groups for reference controls that have the same fluorochrome, label, and lot information in order to use the corresponding control for unmixing.</p> <p>Select the preferred SSC channel for unmixing (SSC for the signal from the violet laser (default), or SSC-B for the signal from the blue laser).</p>
Batch Analysis	<p>Select the default output file type for batch analysis reports (PDF, CSV, or both).</p> <p>Choose to create a single PDF for all tubes/wells, or individual PDF files for each tube/well.</p>

Worksheet Preferences

The Worksheet tab allows you to change the way elements are displayed in the worksheet. Header and footer properties are also adjusted in the Worksheet tab.

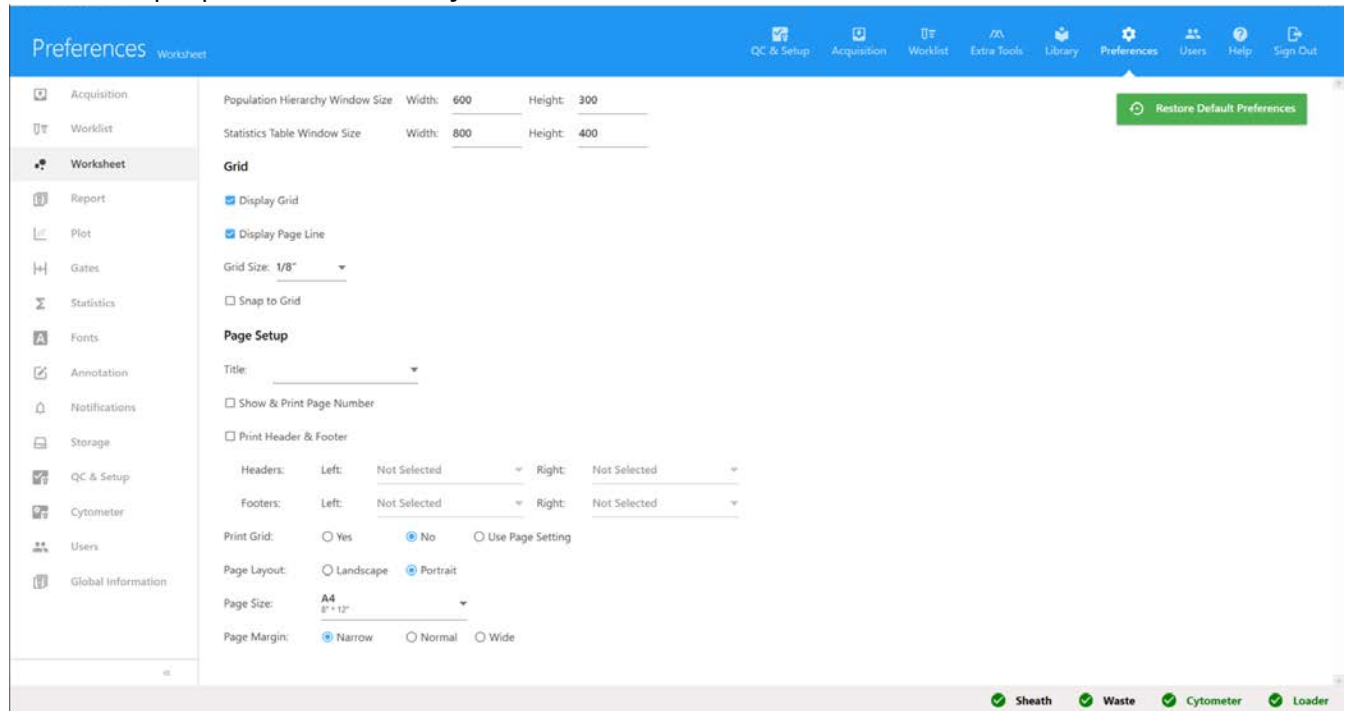

The following table describes the options in the Worksheet preferences.

Item	Description
Population Hierarchy Window Size	Sets the default height and width for the population hierarchy experiment element.
Statistics Table Window Size	Sets the default height and width for the statistics table.
Grid	<p>Display Grid – Toggles on/off the display of grid lines in the worksheet.</p> <p>Display Page Line – Toggles on/off the page break line in the worksheet.</p> <p>Grid Size – Modifies the size of the grid squares. Options include 1", 1/2", 1/4", and 1/8".</p> <p>Snap to Grid – Toggles on/off the ability for the worksheet elements to snap to and line up with the grid lines on the worksheet.</p>

Item	Description
Page Setup	<p>Title – Select a worksheet title from a list of default titles. The title is shown when the worksheet is printed or exported as a PDF.</p> <p>Show & Print Page Number – Toggles whether the page number is shown and printed.</p> <p>Print Header & Footer – Toggles whether the header and footer are printed. Allows you to select the text that is displayed in the left and right headers and footers.</p> <p>Print Grid – Toggles whether the grid is printed. Can also be set to use Page Setting.</p> <p>Page Layout – Toggles between landscape and portrait.</p> <p>Page Size – Sets the page size according to standard paper sizes.</p> <p>Page Margin – Sets the margins of the page to Narrow, Normal, or Wide.</p>

Plot Preferences

The display properties of pseudocolor, dot, and histograms plots can be adjusted in the Plot tab.

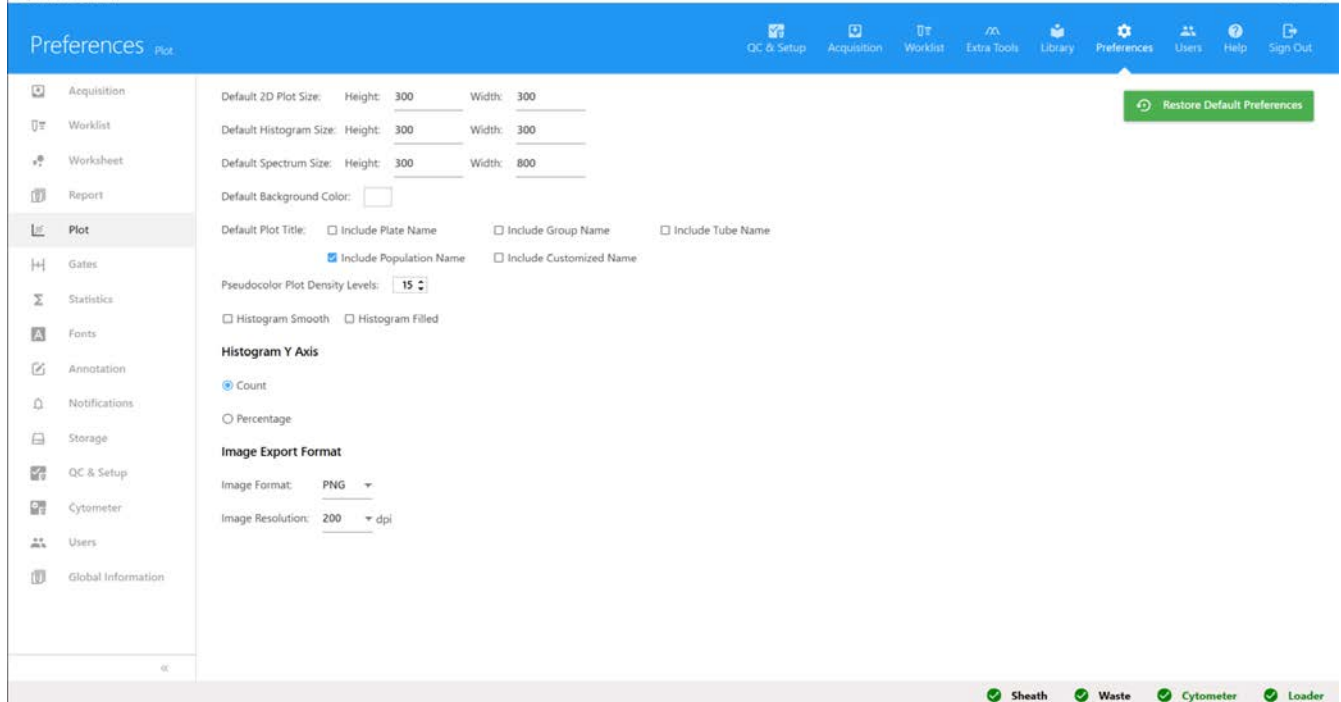

The following table describes the options in the Plot preferences.

Item	Description
Default 2D Plot Size	Set the default height and width of the pseudocolor plots and dot plots in pixels.
Default Histogram Size	Set the default height and width of histograms in pixels.
Default Spectrum Size	Set the default height and width of spectrum plots in pixels.

Item	Description
Default Background Color	Set the default background color for all plots. Click to select from the available colors.
Default Plot Title	Customize the title of all plots to include the plate name, group name, tube name, population name, and/or a custom name.
Pseudocolor Plot Density Levels	Increase or decrease the number of density levels displayed in the pseudocolor plot.
Histogram Smooth	Set whether histogram distributions are smoothed.
Histogram Filled	Set whether histogram distributions are filled.
Histogram Y Axis	Set the scale of the histogram y-axis to count or percentage.
Image Export Format	Select the format (PNG, TIFF, or JPEG) and resolution (96, 200, 300, or 500 dpi) for exported images.

Gates Preferences

Gate properties can be adjusted in the Gates tab.

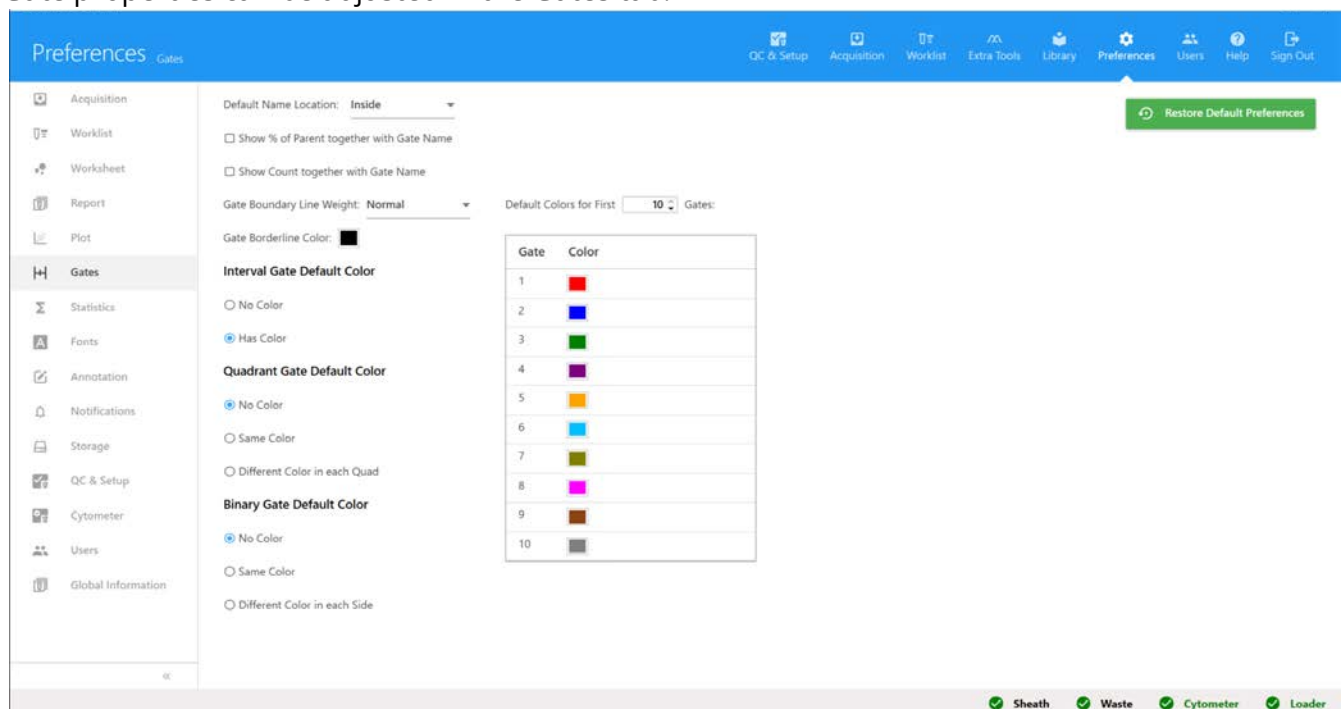

The following table describes the options in the Gates preferences.

Item	Description
Default Name Location	Select where the gate name is displayed with respect to the gate itself.
Show % of Parent together with Gate Name	Toggles on/off the display of the % of Parent with the gate name.

Item	Description
Show Count together with Gate Name	Toggles on/off the display of the population count with the gate name.
Gate Boundary Line Weight	Sets the thickness of the line drawn by the gate.
Default Colors for First X Gates	Set the number of gates (1–10) that will follow the color scheme detailed in the gate color table. The order in which the colors appear can be changed.
Interval Gate Default Color	Toggles on/off whether the population captured by the interval gate has a default color.
Quadrant Gate Default Color	Select whether the population captured by the quadrant gate has a default color, and if so if each quadrant has a different color.
Binary Gate Default Color	Select whether the population captured by the binary gate has a default color.

Statistics Preferences

The default degree of precision (number of decimal places) of the statistics displayed in the worksheet can be modified in the Statistics tab.

The precision for the following statistics can be adjusted: Mean, rSD, % rCV, Mean, Max, Min, SD, % CV, % Total, % Parent, and % Grand Parent.

The screenshot shows the 'Preferences' window with the 'Statistics' tab selected. The 'Decimal Places' section contains the following table:

Statistics Variable	Decimal Places
Median	0
rSD	0
% rCV	2
Mean	0
Max	0
Min	0
SD	0
% CV	2
% Total	2
% Parent	2
% Grand Parent	2
% Specified Gate	2
Count/uL	2
Absolute Count	2

The interface also includes a 'Restore Default Preferences' button and a status bar at the bottom with indicators for Sheath, Waste, Cytometer, and Loader.

Fonts Preferences

The Fonts tab allows you to change the font properties of each display element.

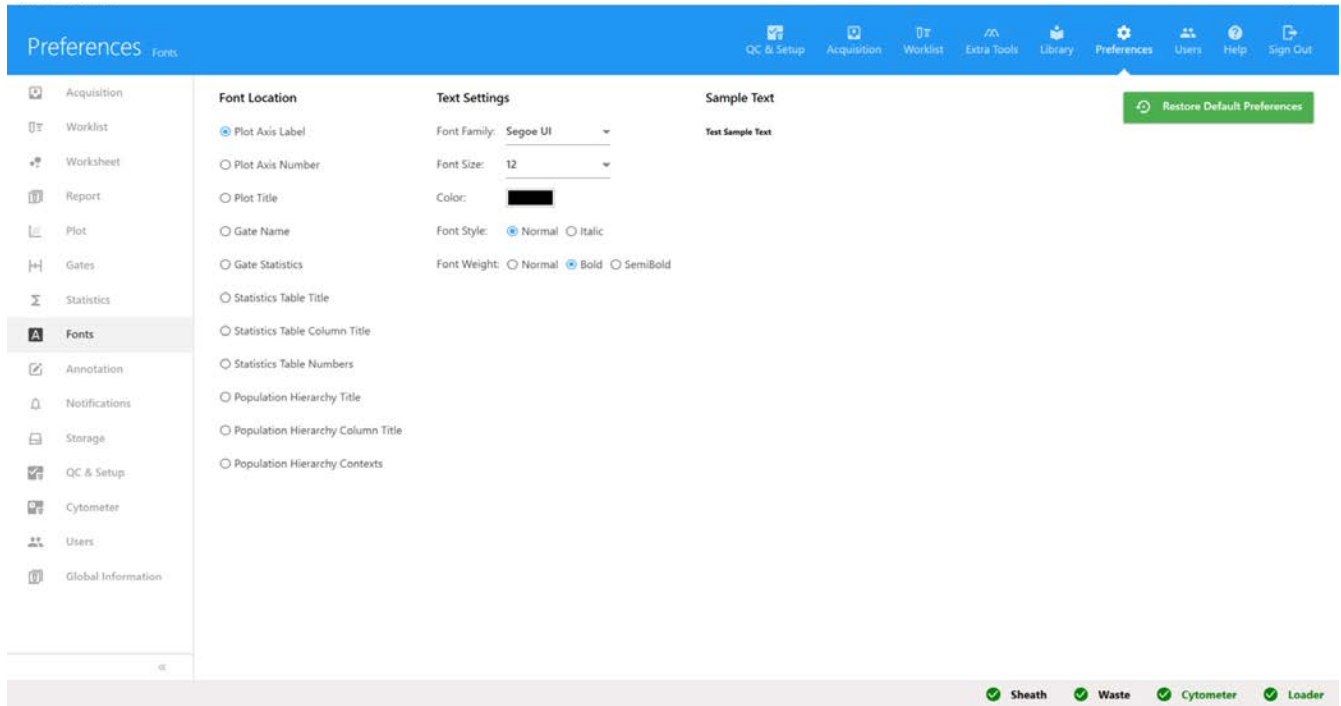

The following table describes the options in the Fonts preferences.

Item	Description
Font Locations	Select which display element's font to modify.
Text Settings	Font Family – Select the font family. Font Size – Select the font size. Color – Select the font color. Font Style – Toggles between normal and italic. Font Weight – Select normal, bold, or semibold.
Sample Text	Shows a preview of the text with the properties set in the Text Settings.

Notifications Preferences

The Notifications tab allows you to change certain notification settings in the Acquisition and Extra Tools modules.

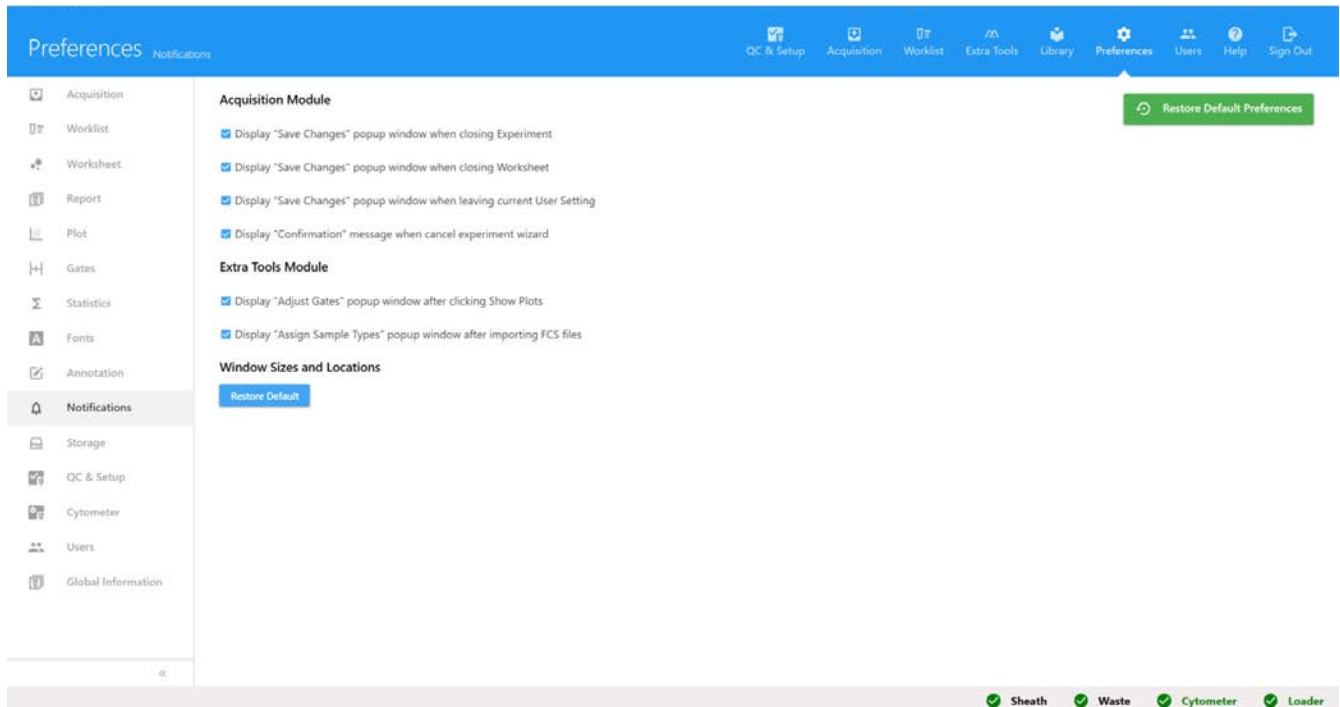

The following table describes the options in the Notifications preferences.

Item	Description
Acquisition Module	Toggles whether to display the Save Changes pop-up window when closing an Experiment, Worksheet, and User Settings, as well as whether to display a confirmation message when canceling the experiment wizard.
Extra Tools Module	Toggles whether to display the instructional dialog boxes in the Extra Tools module.
Window Sizes and Locations	Select Restore Default to set pop-up window sizes and locations to the defaults.

Storage Preferences

The Storage tab allows administrators to set the default storage locations for the experiment FCS files and setup FCS files. This option is available only for administrators.

■ **NOTE:** Do not move files stored in these folders.

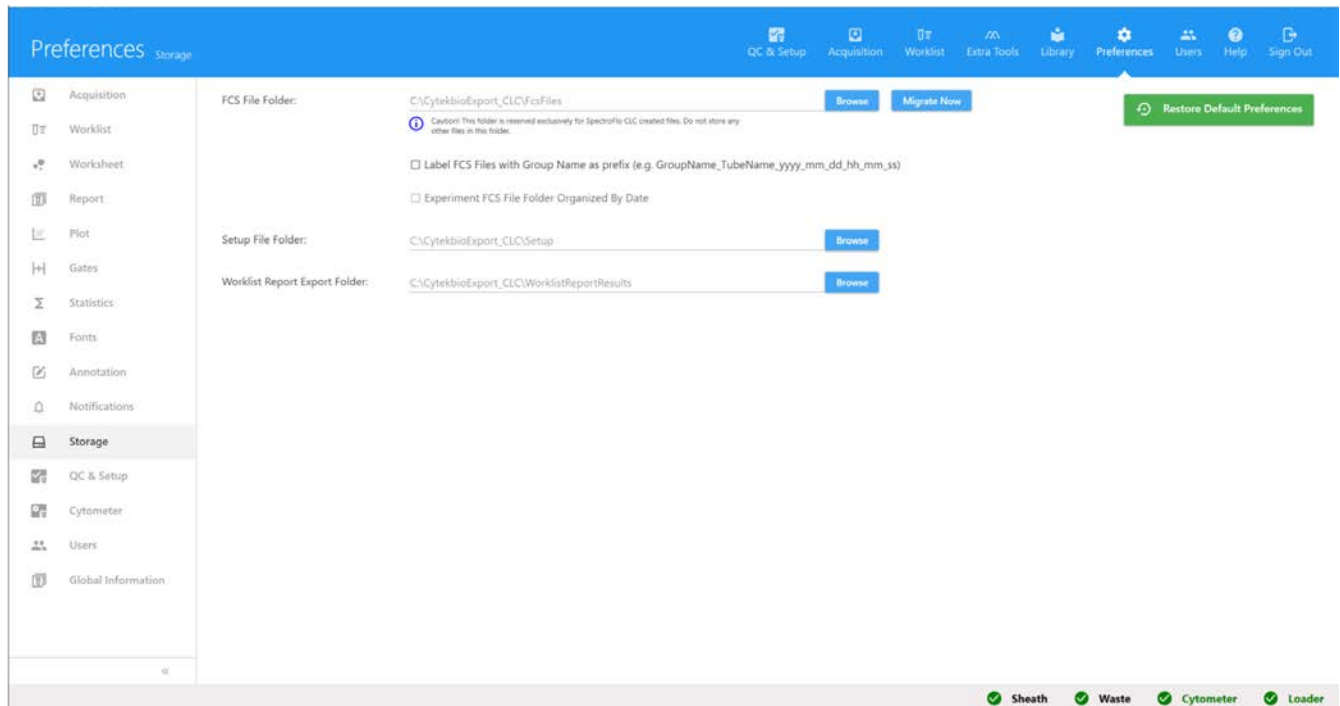

The following table describes the options in the Storage preferences.

Item	Description
FCS Files Folder	<p>Select the folder where FCS files are saved. FCS files from experiments where only raw data was acquired, as well as FCS files from experiments where live unmixing was performed are stored here. For experiments where live unmixing is performed, both raw and unmixed FCS files are saved.</p> <ul style="list-style-type: none"> You can select to label FCS files with group names as the prefix. Note that you can set the default group name in Acquisition preferences. You can select to organize FCS file folders by date. If not selected, FCS files are ordered by experiment name, without a parent folder indicating the date. <p>If you change the default folder where FCS files are saved and want to move existing experiments to the specified folder, click Migrate Now.</p>
Setup FCS Files Folder	<p>Select the folder where FCS files generated by QC & Setup procedures are saved.</p>

QC Setup Preferences

The QC Setup tab allows you to select the days/months of QC reports to display in the Reports section of the Cytometer QC menu in the QC & Setup module.

Preferences QC & Setup

QC & Setup Acquisition Worklist Worksheet Report Plot Gates Statistics Fonts Annotation Notifications Storage **QC & Setup** Cytometer Users Global Information

Display Daily QC Reports

Last 30 days
 Last 3 months
 Last 12 months

Restore Default Preferences

Sheath Waste Cytometer Loader

Cytometer Preferences

Preferences Cytometer

QC & Setup Acquisition Worklist Worksheet Extra Tools Library Preferences Users Help Sign Out

Acquisition Worklist Worksheet Report Plot Gates Statistics Fonts Annotation Notifications Storage QC & Setup **Cytometer** Users Global Information

Default Carrier Type:

Manual Tube

Fluidics

Skip Fluidics Boost when Starting Acquisition for High and Medium Flow Rates
 Enable Bubble/Clog Detection

Cytometer Warm Up

Enable data collection during system warm up

Sample Carrier Configuration

Name	Enable	SIT Lift Distance	Default Loader Setting
Manual Tube	<input checked="" type="checkbox"/>	0.75	-
96 U-Bottom	<input checked="" type="checkbox"/>	1.5	Default
96 V-Bottom	<input checked="" type="checkbox"/>	1.7	Default
96 Flat-Bottom	<input checked="" type="checkbox"/>	1.5	Default
Nunc 1.3mL 96 Deep	<input checked="" type="checkbox"/>	1.5	Default
Nunc 2mL 96 Deep	<input checked="" type="checkbox"/>	1.5	Default
Brand 1mL 96 Deep	<input checked="" type="checkbox"/>	1.5	Default
Brand 2.2mL 96 Deep	<input checked="" type="checkbox"/>	1.5	Default
40 Tube Rack	<input checked="" type="checkbox"/>	1.5	Default

Restore Default Preferences

Sheath Waste Cytometer Loader

The following table describes the options in the Cytometer preferences.

Item	Description
Default Carrier type	Allows you to set a carrier as default
Fluidics	Use checkboxes to set preferences for fluidics boost and bubble/clog detection.
Cytometer Warmup	Click checkbox to enable data collection upon warmup.
Sample Carrier Configuration	You can have default, high throughput, or low carryover selected for each carrier type

Users

User accounts can be managed in the Users module. User account information and use time are stored in the module.

There are two types of user accounts—SuperUser and User. Only administrators can manage user accounts.

Managing Users

Administrators can add, remove, edit, and disable user accounts from the User tab. User passwords can also be changed/reset. The User tab lists all users and displays the type and status of each.

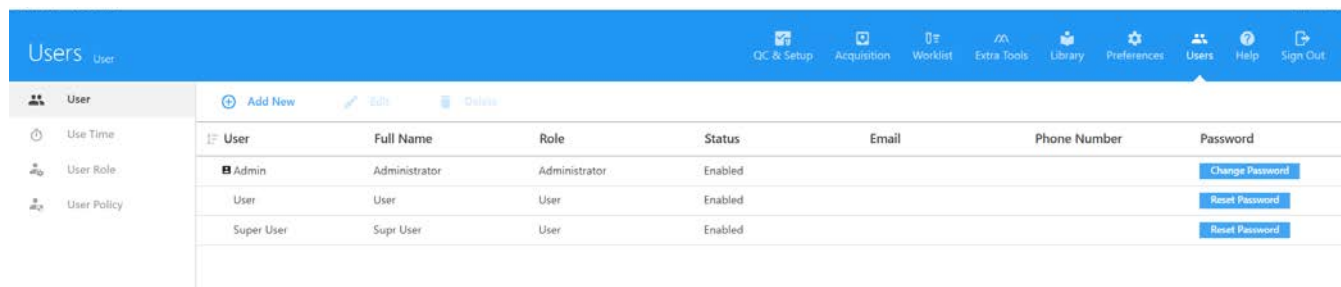

The screenshot shows the 'Users' module interface. At the top, there is a navigation bar with icons for 'QC & Setup', 'Acquisition', 'Worklist', 'Extra Tools', 'Library', 'Preferences', 'Users', 'Help', and 'Sign Out'. Below the navigation bar, there is a sidebar with 'User' selected. The main area displays a table of users with columns for 'User', 'Full Name', 'Role', 'Status', 'Email', 'Phone Number', and 'Password'. The table contains three rows: 'Admin' (Administrator, Administrator, Enabled), 'User' (User, User, Enabled), and 'Super User' (Supr User, User, Enabled). Each row has a 'Change Password' or 'Reset Password' button.

User	Full Name	Role	Status	Email	Phone Number	Password
Admin	Administrator	Administrator	Enabled			Change Password
User	User	User	Enabled			Reset Password
Super User	Supr User	User	Enabled			Reset Password

Adding a New User Account

- 1 Click **+** Add New in the User tab of the Users module.

This option is available only for administrators.

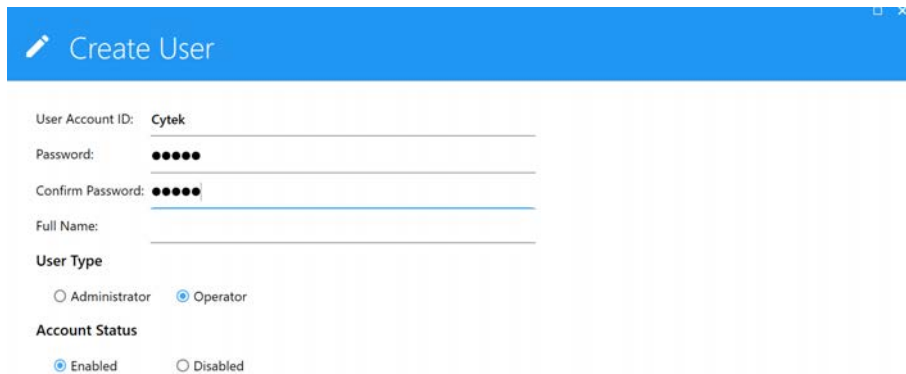

The screenshot shows the 'Create User' form. It has a blue header with a pencil icon and the text 'Create User'. Below the header, there are several input fields and radio buttons. The 'User Account ID' field contains 'Cyttek'. The 'Password' and 'Confirm Password' fields are masked with dots. The 'Full Name' field is empty. The 'User Type' section has two radio buttons: 'Administrator' (unselected) and 'Operator' (selected). The 'Account Status' section has two radio buttons: 'Enabled' (selected) and 'Disabled' (unselected).

- 2 Enter a user account ID and password, then enter the password again to confirm.

The user account ID appears in the user name filed in the User's tab.

- 3 (Optional) Enter the user's full name.
- 4 Select the user type—Administrator, SuperUser, or User.
- 5 Select the user status—enabled or disabled.
- 6 Click Save.

Editing a User Account

- 1 Select the user from the User tab of the Users module, then click Edit.

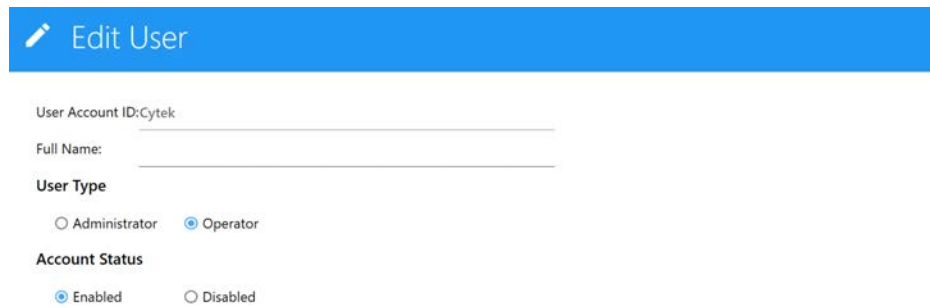

User Account ID:Cytek

Full Name:

User Type

Administrator Operator

Account Status

Enabled Disabled

- 2 You can edit or add a user name. You can also change the user type and/or account status.
- 3 Click Save.

Resetting a User Password

An administrator can change their or another administrator's password or reset an operator's password.

- 1 Select the user from the User tab of the Users module.
- 2 Click Reset Password.

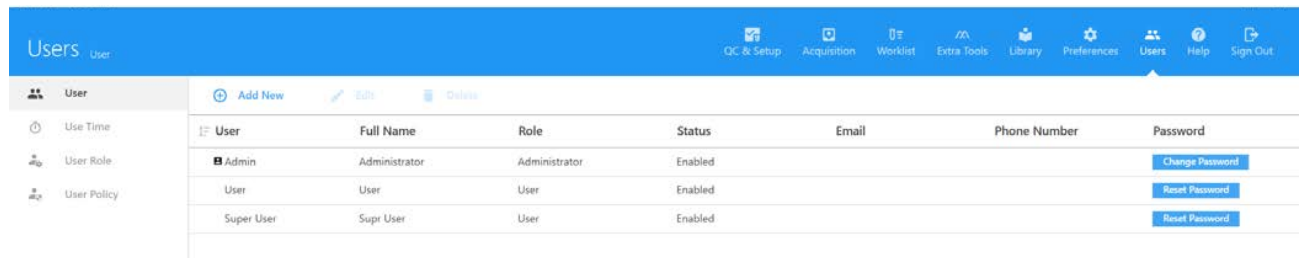

User	Full Name	Role	Status	Email	Phone Number	Password
Admin	Administrator	Administrator	Enabled			Change Password
User	User	User	Enabled			Reset Password
Super User	Supr User	User	Enabled			Reset Password

- 3 A dialog opens displaying the new password.
- 4 Make note of the password, and click OK.

Removing a User Account

To remove a user account, select the user from the User tab of the Users module, then click Remove. When you remove a user account all the account information and that data acquired by that user is deleted. The FCS files saved by the user are retained.

Use Time

Select the Use Time tab of the Users module.

Use Time shows the total daily, weekly, or monthly use time (duration) and number of sessions that each user is on the system. Choose Admin, User, or SuperUser to view and export the use times for the respective user account.

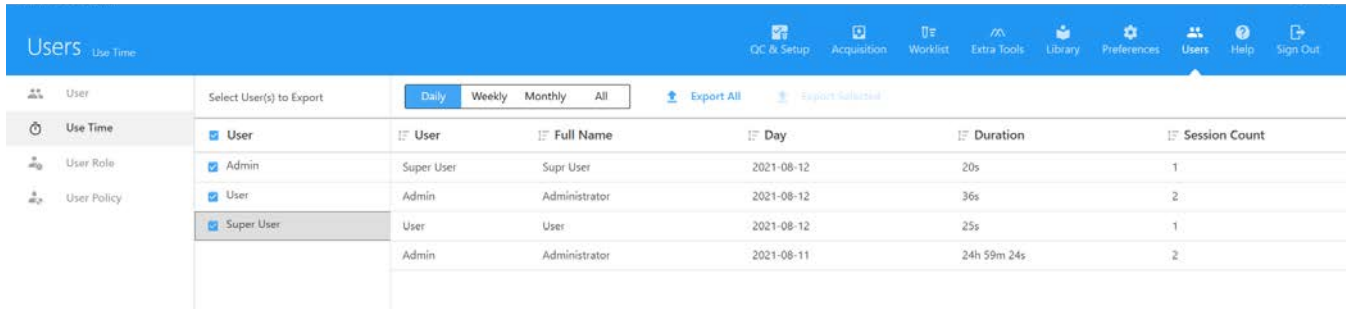

The screenshot shows the 'Users - Use Time' interface. On the left, there are navigation options: 'User', 'Use Time', 'User Role', and 'User Policy'. The 'Use Time' tab is selected. Below the navigation, there is a 'Select User(s) to Export' section with radio buttons for 'Daily', 'Weekly', 'Monthly', and 'All'. The 'Daily' option is selected. To the right of this section are 'Export All' and 'Support Helpdesk' buttons. The main area contains a table with the following columns: 'User', 'Full Name', 'Day', 'Duration', and 'Session Count'. The table lists sessions for three user roles: Admin, User, and Super User.

User	Full Name	Day	Duration	Session Count
Admin	Super User	2021-08-12	20s	1
User	Administrator	2021-08-12	36s	2
Super User	User	2021-08-12	25s	1
	Admin	Administrator	24h 59m 24s	2

To see the individual login sessions for each day, select Login Sessions. Choose Admin, User, or SuperUser to view and export the login sessions for the respective user account. The log on and log off times for each session, as well as the session duration are displayed. Administrators can manage the list of login sessions by deleting all sessions before a specified date. To delete sessions, click Manage Use Time, select the date, and click Delete.

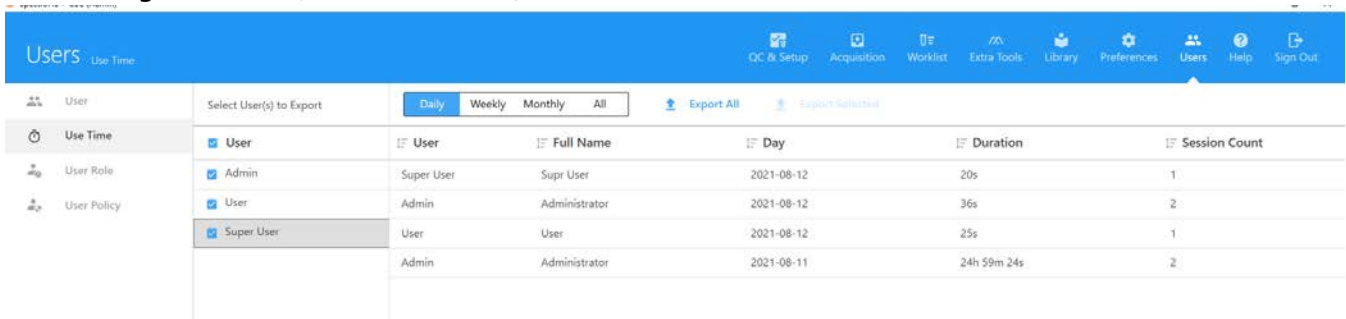

This screenshot is identical to the one above, showing the 'Users - Use Time' interface with the same table of user sessions.

User	Full Name	Day	Duration	Session Count
Admin	Super User	2021-08-12	20s	1
User	Administrator	2021-08-12	36s	2
Super User	User	2021-08-12	25s	1
	Admin	Administrator	24h 59m 24s	2

Administrators can export daily, weekly, and monthly use times and login session to .csv files by selecting the user(s) and session dates and clicking Export or selecting Admin, User, or SuperUser and clicking Export All to export all use times or login sessions.

User Role

Administrators can edit the privileges for User and SuperUser user roles. Administrators can also create and edit new custom user roles. Administrator privileges cannot be changed.

Editing a User Role

- 1 Select User Role from the Users tab, then select the user name (role) you wish to edit.
The default user roles (and names) are Administrator, SuperUser, and User. The Administrator role cannot be edited.
- 2 Click Edit to edit the selected user role.
- 3 Edit the user role privileges, then click Save.

See “User Role Privileges” in the following section.

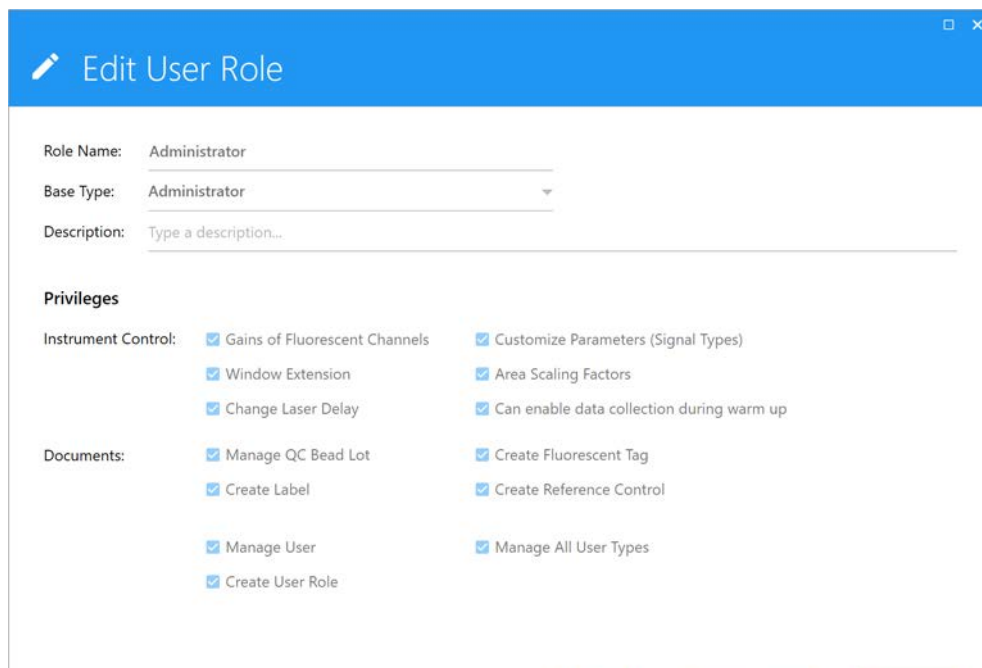

- If you wish to restore user role privileges to the defaults, click Restore Default in the Edit User Role window.

User Role Privileges

The following table shows the privileges for the three default user types (Administrator, SuperUser, and User). Administrators can edit the privileges for the SuperUser and User. Administrator privileges cannot be edited.

Privileges	User	SuperUser	Administrator
Instrument Control			
Change fluorescence gains		✓	✓
Customize parameters (signal types)		✓	✓
Window extension		✓	✓
Area scaling factors	✓	✓	✓
Change laser delay		✓	✓
Enable data acquisition during warm up (cytometer preference)		✓	✓
Library Documents			
Manage QC bead lot		✓	✓
Create fluorescent tags	✓	✓	✓
Create label	✓	✓	✓
Create reference controls	✓	✓	✓

Privileges	User	SuperUser	Administrator
User Management			
Manage users		✓	✓
Manage all user types			✓
Create user role			✓

Creating a User Role

Administrators can create new user roles based on the privileges of the three default roles.

- 1 Select User Role from the Users tab.
- 2 Click New.
- 3 Enter a name for the new user role.
- 4 Select the base type for new role. Base types are Administrator, SuperUser, and User.

The new role can have the same privileges as the selected base type. You can remove some privileges but you cannot grant more privileges than the base type has. For example, if you want the new user role to manage QC bead lot information, select SuperUser as the base type, as the User base type does not have this privilege.

Create User Role

Role Name:

Base Type:

Description:

Privileges

Instrument Control:

- Gains of Fluorescent Channels
- Window Extension
- Change Laser Delay
- Customize Parameters (Signal Types)
- Area Scaling Factors
- Can enable data collection during warm up

Documents:

- Manage QC Bead Lot
- Create Label
- Manage User
- Create User Role
- Create Fluorescent Tag
- Create Reference Control
- Manage All User Types

- 5 (Optional) Enter a description.
- 6 Click Save.

The new user role appears in the Name list.

Deleting a User Role

Administrators can delete a custom user role.

- 1 Select User Role from the Users tab.
- 2 Click Delete.
- 3 Click Delete to confirm deletion.

User Policy

Administrators can configure general password and login security policies.

- 1 Select User Policy from the Users tab to display the user policies.

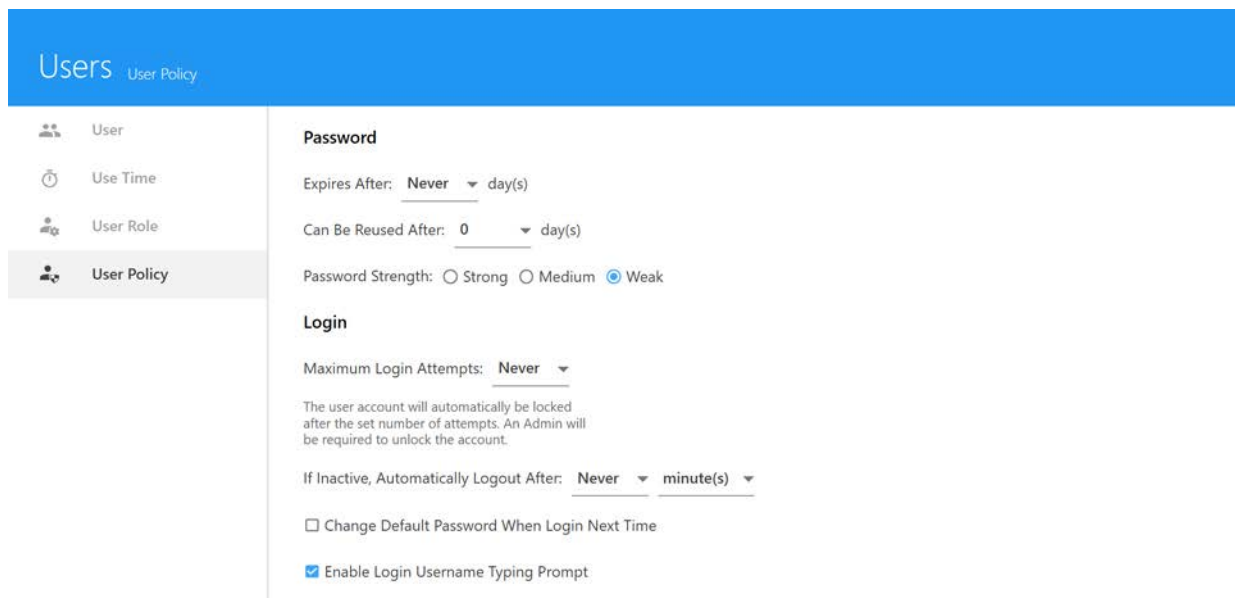

The screenshot shows the 'User Policy' configuration page. The left sidebar has 'User Policy' selected. The main content area is divided into 'Password' and 'Login' sections. The 'Password' section includes: 'Expires After: Never' (dropdown), 'Can Be Reused After: 0' (dropdown), and 'Password Strength: Strong, Medium, Weak' (radio buttons, with 'Weak' selected). The 'Login' section includes: 'Maximum Login Attempts: Never' (dropdown), a note about account locking, 'If Inactive, Automatically Logout After: Never' (dropdown), 'minute(s)' (dropdown), 'Change Default Password When Login Next Time' (checkbox), and 'Enable Login Username Typing Prompt' (checkbox, which is checked).

- 2 Select the following:

- if and when passwords expire
- if and when passwords can be reused
- password strength
 - strong is 8–20 characters with upper-case and lower-case letters, at least one number, and at least one special character
 - medium is 6–20 characters with letters and numbers
 - weak has no restrictions
- if and when a maximum number of login attempts fail (users are locked out of SpectroFlo after the selected number of unsuccessful login attempts is reached)
- if and when users are automatically logged out if inactive for the selected time (1 minute to 45 hours, in various increments)
- change default password when login next time (if the default password Rainbow is set, the user will be prompted to create a new password)
- enable login username typing prompt (as you begin to type when logging in, a list of user names with matching characters appears)

Unmixing and Compensation

Spectral Unmixing

Spectral unmixing is an important concept to understand how data is generated and analyzed using the NL-CLC flow cytometer with SpectroFlo software. Spectral unmixing is used to identify the fluorescence signal for each fluorophore used in a given experiment.

Understanding Full Spectrum Flow Cytometry

Because fluorophores emit light over a range of wavelengths, optical filters are typically used to limit the range of frequencies measured by a given detector. However, when two or more fluorophores are used, the overlap in wavelength ranges often makes it impossible for optical filters to isolate light from a given fluorophore. As a result, light emitted from one fluorophore appears in a non-primary detector (a detector intended for another fluorophore). This is referred to as spillover. In conventional flow cytometry, spillover can be corrected by using a mathematical calculation called compensation. Single-stained controls must be acquired to calculate the amount of spillover into each of the non-primary detectors.

The ability to measure a fluorophore's full emission spectra allows the system to use a different method for isolating the desired signal from the unwanted signal. The key to differentiate the various fluorophores is for those to have distinct patterns or signatures across the full spectrum. Because the system is looking at the full range of emission of a given fluorophore, and not only the peak emission, two dyes with similar emission but different spectral signatures can be distinguished from each other. The mathematical method to differentiate the signals from multiple fluorophores/dyes is called spectral unmixing and results in an unmixing matrix that is applied to the data. While not mathematically identical to conventional compensation, the overall principal is the same. Just as for compensation, single-stained controls, identified in SpectroFlo software as reference controls, are still necessary, as they provide the full fluorescence spectra information needed to perform spectral unmixing.

One advantage of unmixing is the ability to extract the autofluorescence of a sample and treat it as a separate parameter. This is especially useful when running assays with particles that have high autofluorescence and for which that high background has an impact in the resolution of the fluorescent signals. Per experiment, you can define one unstained control or multiple unstained controls (one per group), depending on whether the multicolor samples have the same or different autofluorescence signatures.

In the following figure on the left, spectrum plots from conventional spectrum viewer shows heavy overlap between Qdot 705 and BV711 peak emission spectra. On the right, spectrum plots from NL-CLC show distinct signatures for Qdot 705 and BV711.

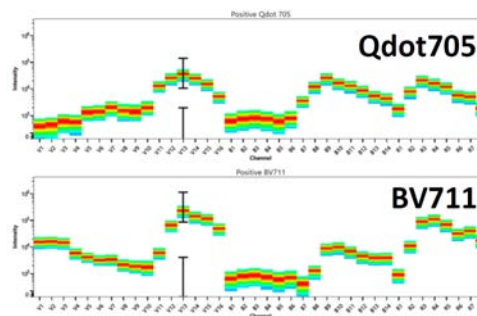
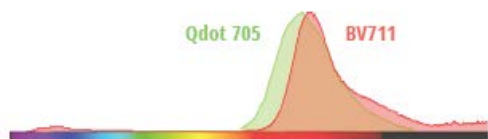

Unmixing Workflows

Unmixing Overview

There are three unmixing workflows available in SpectroFlo software—two in the Acquisition module and one in the Extra Tools module:

- live unmixing during acquisition
- post-acquisition unmixing (in the Acquisition module)
- post-acquisition unmixing (in the Extra Tools module)

When data is acquired with live unmixing, references are acquired as raw data either in the experiment as part of the reference group or previously acquired in the QC & Setup module as reference controls. References for *all* fluorescent tags used in a given experiment must be present in the system in order for live unmixing of multicolor samples to occur. The live unmixing functionality allows you to visualize unmixed data during acquisition.

Reference Controls for Unmixing

Depending on when you unmix the data, you will use the following controls for unmixing.

Unmixing	Reference Controls
Live unmixing	Reference controls run in the experiment or reference controls run in QC & Setup
Post-acquisition unmixing in Acquisition module	Reference controls run in the experiment or reference controls run in QC & Setup
Post-acquisition unmixing in Extra Tools module	Any FCS files from samples run in any experiment

Multicolor samples can be acquired as raw data and unmixed post acquisition as well. This can be done in either the Acquisition module or the Extra Tools module.

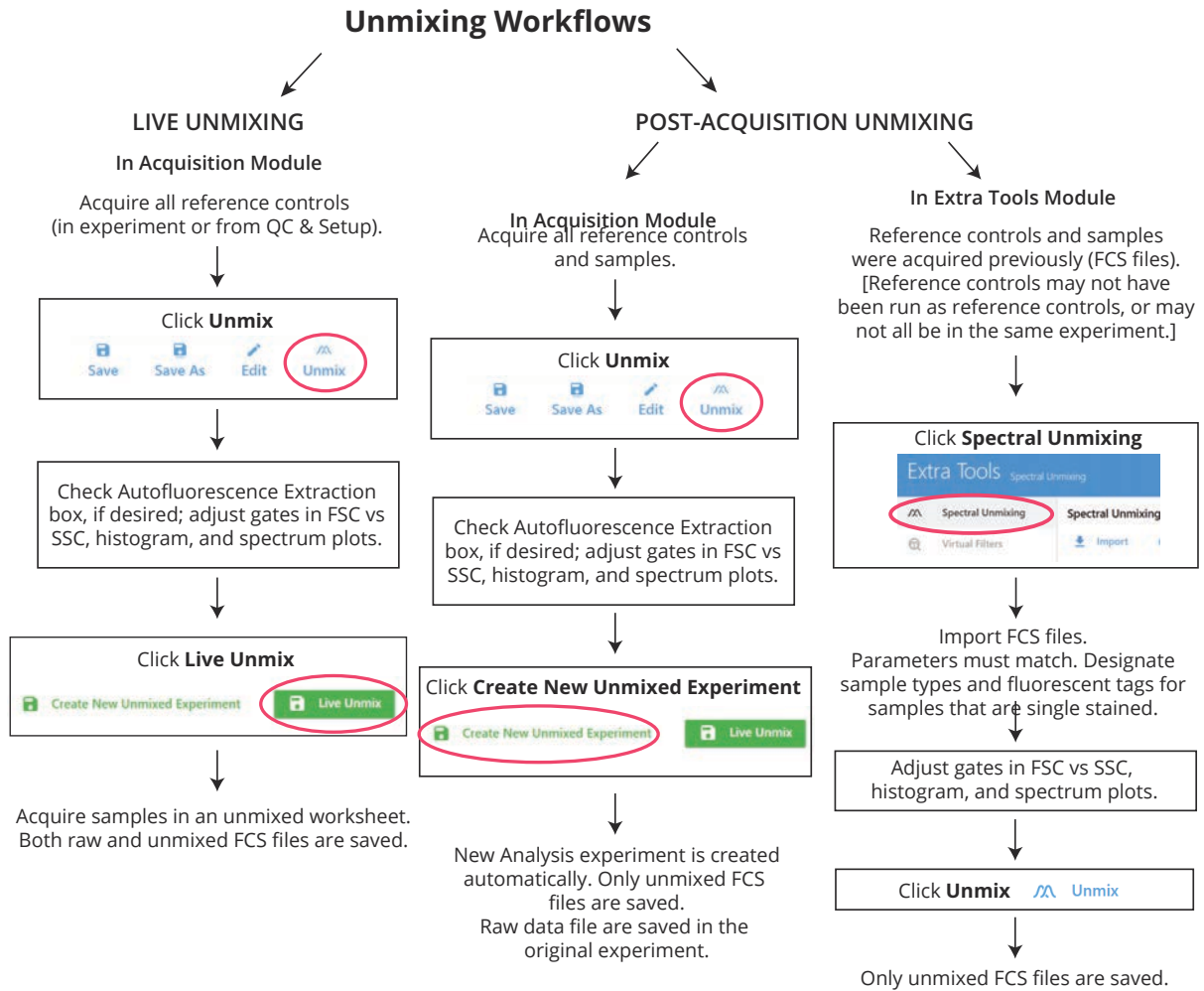

Negative/Unstained Controls

In addition to positive reference controls needed for spectral unmixing, an unstained control is also necessary to assess **autofluorescence**. The unstained control needs to be of the same type and prepared in the same way as the samples, as this will ensure accurate unmixing and autofluorescence extraction, if desired. Ideally, your reference controls, negative control, and samples will all be the same sample type and prepared in the same way.

In addition to assessing autofluorescence, **fluorescence spillover** must also be determined. To correct for spillover, the unstained autofluorescence control can be used if it matches the sample and reference control type. However, if your reference controls do not match your sample type and

do not contain a negative population in each tube (have only positive peaks), you must use a separate spillover unstained control that matches your reference control type.

Controls

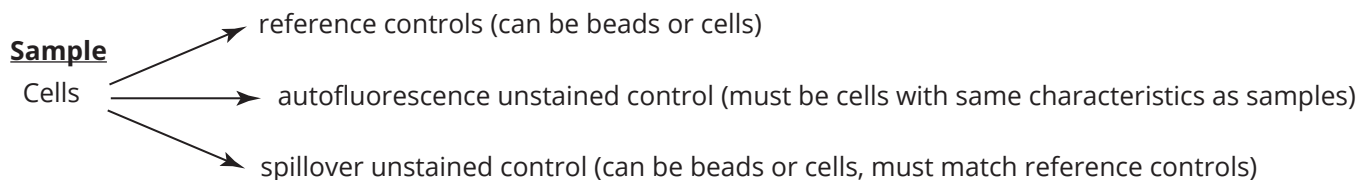

Live Unmixing

Samples can be unmixed during acquisition. Live unmixing can be performed with the reference group acquired during the experiment, the reference controls (run during QC & Setup and stored in the system), or a combination of both.

For each sample tube that is live unmixed, two FCS files are generated, one that is composed of raw data and one that is composed of unmixed data.

Live unmixed data can be analyzed in unmixed worksheets in the Acquisition module. Unmixed worksheets are different from raw worksheets, as they only display fluorescence information categorized into the defined fluorescent tags for each of the experiments.

To Perform Live Unmixing

- 1 Create a new experiment with fluorescent tags defined. Create a reference group in the experiment with the fluorescent tags, if there are any that have not already been stored as reference controls. See “Creating a New Experiment” on page 54 for details.

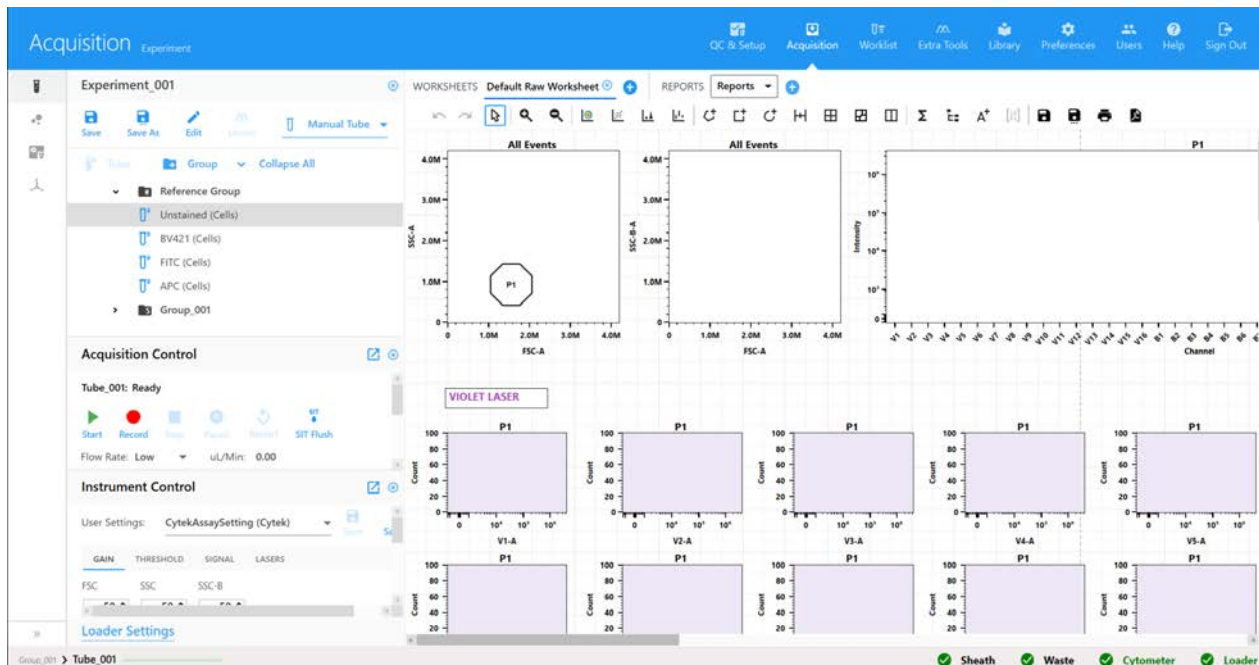

- 2 To view the data for the reference control tubes, make sure CytekAssaySetting is selected, then click Start. If necessary, use the Instrument Controls to adjust the settings so that all events are on scale. View all the controls, as well as the multi-color tube, and make any instrument adjustments to ensure populations are on scale before you begin recording.

To edit the acquisition criteria, click **Edit** at the experiment level and select the **Acquisition** tab. Or, to edit the properties of a single tube, right-click a tube and select **Tube Properties**.

■ **NOTE:** Keep in mind the more events you acquire, the longer it takes to unmix the data.

3 Click **Record** when you are ready to begin acquisition. Acquisition stops when the first stopping criterion is met.

■ **NOTE:** If necessary, you can pause to change the flow rate.

4 When all reference controls are acquired, click **Unmix** in the upper-left toolbar.

5 For the unstained controls, we recommend selecting **Use Control from Experiment** if unmixing with controls you acquired in the experiment.

6 If necessary, for the stained controls, select **Use Control from Library** if unmixing with reference controls run in **QC & Setup**.

Checkmarks appear for those controls coming from **QC & Setup**. The checkbox is only active if reference controls for those fluorescent tags are already saved with the reference controls from the **QC & Setup** module.

UNSTAINED CONTROLS

Use Control from Library

Use Control from Experiment

Name	Control Type
Reference Group - Unstained (Cells)	Cells

STAINED CONTROLS

<input type="checkbox"/> From Library	Fluorescent Tag	Control	Unstained	Generic
<input checked="" type="checkbox"/>	FITC	FITC (Cells)	Unstained	Generic
<input type="checkbox"/>	FITC	FITC (Cells)	Unstained	<input checked="" type="checkbox"/>

7 Click **Next**.

8 Use the **Identify Positive/Negative Populations** tab to include the positive and negative populations for each fluorescent tag in the appropriate gate.

Only the data plots for the samples you acquired are displayed, not for reference controls that you chose to use from the library.

■ **NOTE:** If you need to set the FSC and/or SSC axis to a log scale, select the Log checkbox.

Control	Control Type	Fluorescent Tag	<input type="checkbox"/> FSC Log	<input type="checkbox"/> SSC Log
FITC (Cells)	Single Stained	FITC	<input type="checkbox"/>	<input type="checkbox"/>
Alexa 532 (Cells)	Single Stained	Alexa 532	<input type="checkbox"/>	<input type="checkbox"/>
PE (Cells)	Single Stained	PE	<input type="checkbox"/>	<input type="checkbox"/>
PE-Cy7 (Cells)	Single Stained	PE-Cy7	<input type="checkbox"/>	<input type="checkbox"/>

- Move the polygon gate in the FSC vs SSC plot on the left to include the singlet population. Hold down Ctrl to move all the polygon gates at once.
- Move the positive interval gate in the histogram to include the positively stained population. Move the negative interval gate to include the negative population.
- Move the interval gate on the spectrum plot on the right to select the channel that exhibits the brightest fluorescence intensity. This channel is the peak emission channel for the fluorescent tag.

■ **NOTE:** If one of the controls is questionable or does not contain sufficient data, you can reacquire it or append to it, then unmix again.

Control	Control Type	Fluorescent Tag	<input type="checkbox"/> FSC Log	<input type="checkbox"/> SSC Log
FITC (Cells)	Single Stained	FITC	<input type="checkbox"/>	<input type="checkbox"/>
Alexa 532 (Cells)	Single Stained	Alexa 532	<input type="checkbox"/>	<input type="checkbox"/>
PE (Cells)	Single Stained	PE	<input type="checkbox"/>	<input type="checkbox"/>
PE-Cy7 (Cells)	Single Stained	PE-Cy7	<input type="checkbox"/>	<input type="checkbox"/>
APC (Cells)	Single Stained	APC	<input type="checkbox"/>	<input type="checkbox"/>
Alexa Fluor 700 (Cells)	Single Stained	Alexa Fluor 700	<input type="checkbox"/>	<input type="checkbox"/>
APC-Fire 750 (Cells)	Single Stained	APC-Fire 750	<input type="checkbox"/>	<input type="checkbox"/>
Reference Group - Unstained (Cells)	Unstained	N/A	<input type="checkbox"/>	<input type="checkbox"/>

- (Optional) To see how the reference controls run in the experiment compare to the benchmark reference controls, click Next.

■ **NOTE:** For information on creating benchmarks, see [“Setting Reference Controls as Benchmarks for Reference Control QC”](#) on page 39.

Two options allow you to view how the two reference controls compare—Spectral Profile and Similarity™ Matrix.

- Spectral Profile displays the emission spectrum of the unmixing controls against benchmark spectra designated by the user. The benchmark reference control spectra appear in red and the reference controls appear in black.

A similarity index appears to the right of the plots. A value closer to 1 indicates similar spectral signatures, while a value closer to 0 indicates spectral signatures that are not similar. For comparison to benchmarks, the value should be close to 1. If the value is below 0.97, it will be flagged with a yellow warning symbol. This indicates a mismatch of the unmixing control spectra with the benchmark spectra. If the similarity index falls below this value, it is imperative to check the unmixing control against the reference spectra provided in the fluorochrome guideline found in the Help menu. See “[Similarity™ Matrix](#)” in the following section.

The similarity index can also be used when viewing and comparing the full spectral signatures of any two dyes. Dyes with similar spectral signatures can be challenging to resolve. In this case, it is best to use dyes with a similarity index ≤ 0.98 . See spectrum.cytekbio.com for a full spectrum viewer tool.

If no benchmark control is established for a particular dye, that plot will only display a black line that represents the spectrum of the unmixing control. The similarity index will display N/A.

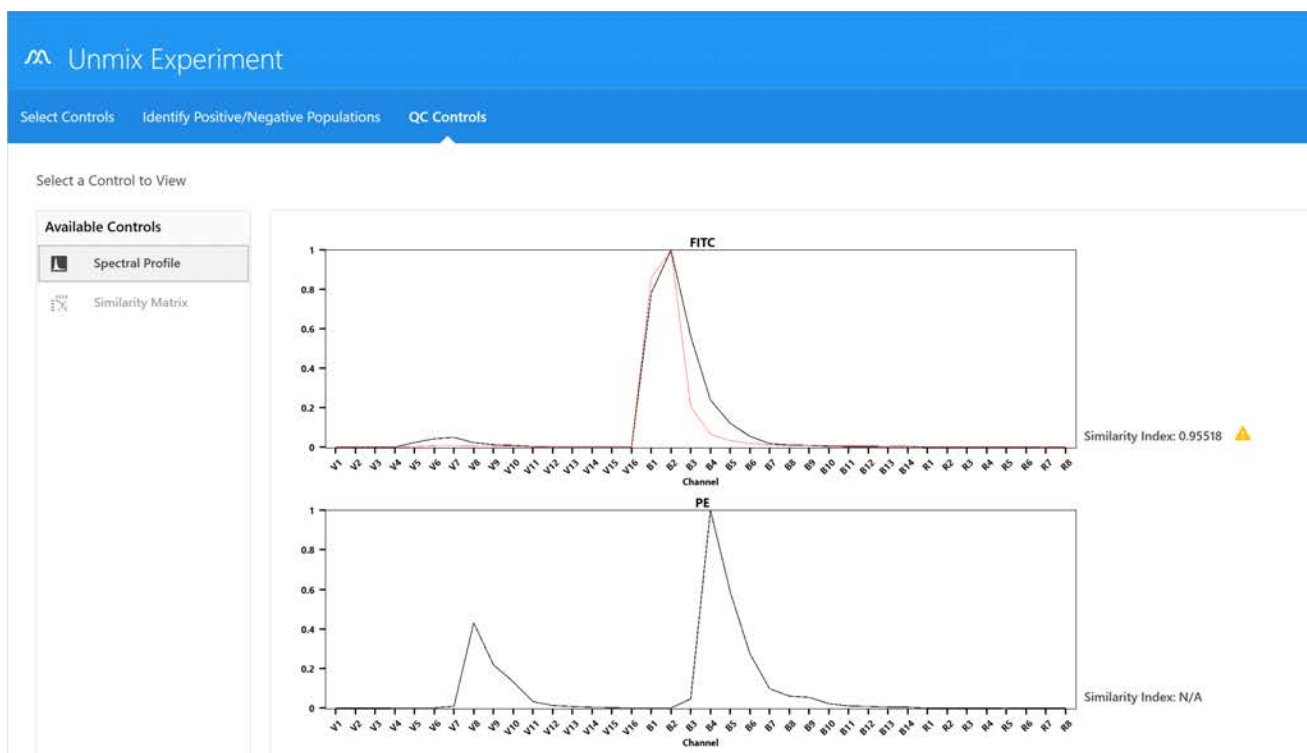

- Similarity™ Matrix displays a similarity index matrix and a complexity index value.

Click View Similarity Index above the matrix to display the indexes for each dye. The Similarity™ Matrix will display the similarity index for each dye against itself and all the other dyes to be unmixed in the experiment.

The complexity index is a measure of how distinguishable a collection of spectral signatures are from each other when unmixed together. It calculates this by looking at the ratio of the

similarity index of the worst overlapping combination of signatures to the best overlapping combination of signatures.

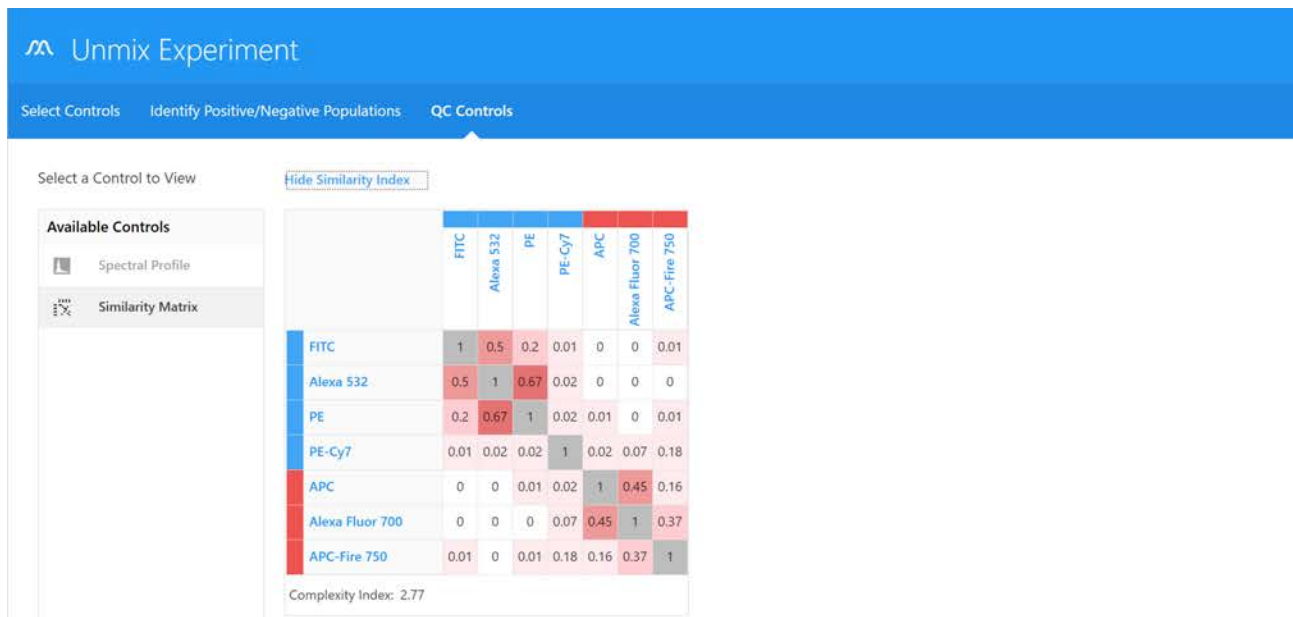

10 Click Live Unmix.

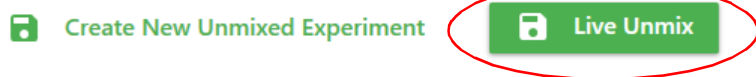

11 The wizard closes and the experiment reappears. The reference group now has the unmixed icon to the left of the tube(s). Select an unmixed worksheet to view the unmixed data.

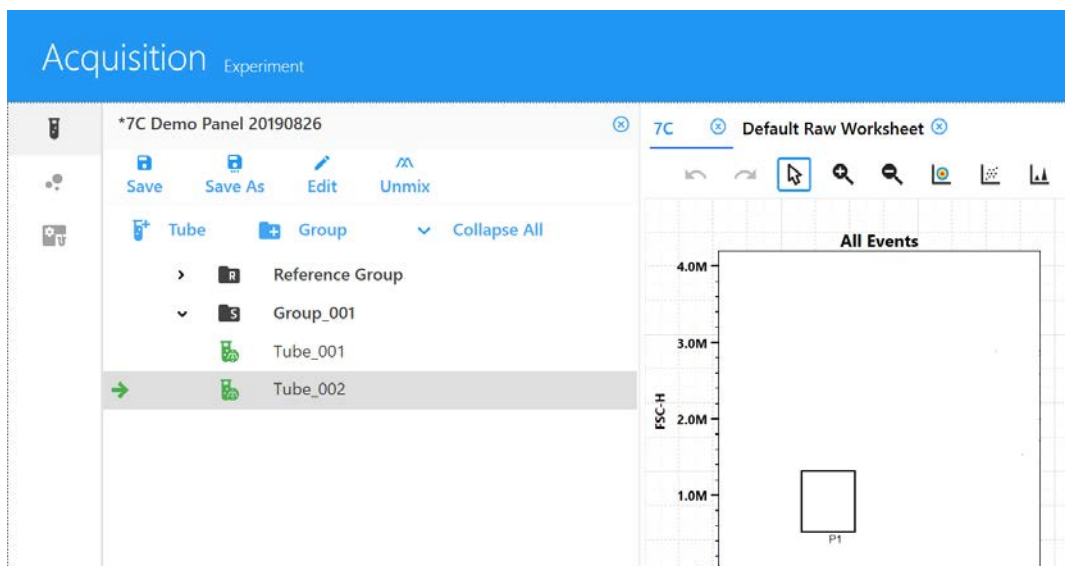

12 Select the sample tube you wish to acquire. The green arrow indicates the tube is selected. Click Start, then Record.

Use My Experiments to open experiments you ran if you wish to review the data or acquire more samples.

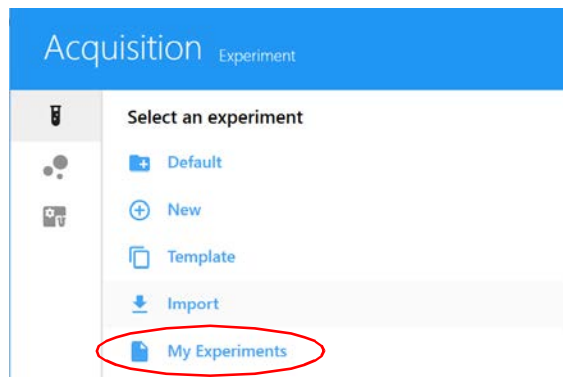

FCS files are stored in the Export folder by default, or the folder you set as the default. See [“Storage Preferences” on page 78](#) for information. FCS files for live unmixing data are saved as both raw data and unmixed data.

Analyzing Data Offline

To analyze data offline, you can click My Experiments, select the experiments you want to export, right-click and select Export. This will export the entire experiment as a ZIP file with all of the FCS files and worksheet templates contained inside. This experiment can be imported into other instances of SpectroFlo software, or unzipped to access the FCS files for analysis using other analysis software.

Post-Acquisition Unmixing

Samples can be acquired as raw data and then unmixed after acquisition is complete. This can be done through two methods:

- post-acquisition unmixing in the Acquisition module (see below)
- post-acquisition unmixing in the Extra Tools module (see [page 98](#))

Post-Acquisition Unmixing in the Acquisition Module

The unmixing wizard in the Acquisition module limits reference controls to those coming from the reference group in the experiment or reference controls run in QC & Setup.

To perform post-acquisition unmixing in the Acquisition module, perform the same workflow as live unmixing except the following:

- 1 Acquire all reference control tubes and sample tubes prior to selecting the Unmix button in the upper-left pane.
- 2 Examine the spectral plots by doing the following, if needed:
 - a. Move the polygon gate in the FSC vs SSC plot on the left to include the singlet population. Hold down Ctrl to move all the polygon gates at once.
 - b. Move the positive interval gate in the histogram to include the positively stained population. Move the negative interval gate to include the negative population.

- c. Move the interval gate on the spectrum plot on the right to select the channel that exhibits the brightest fluorescence intensity. This channel is the peak emission channel for the fluorescent tag.

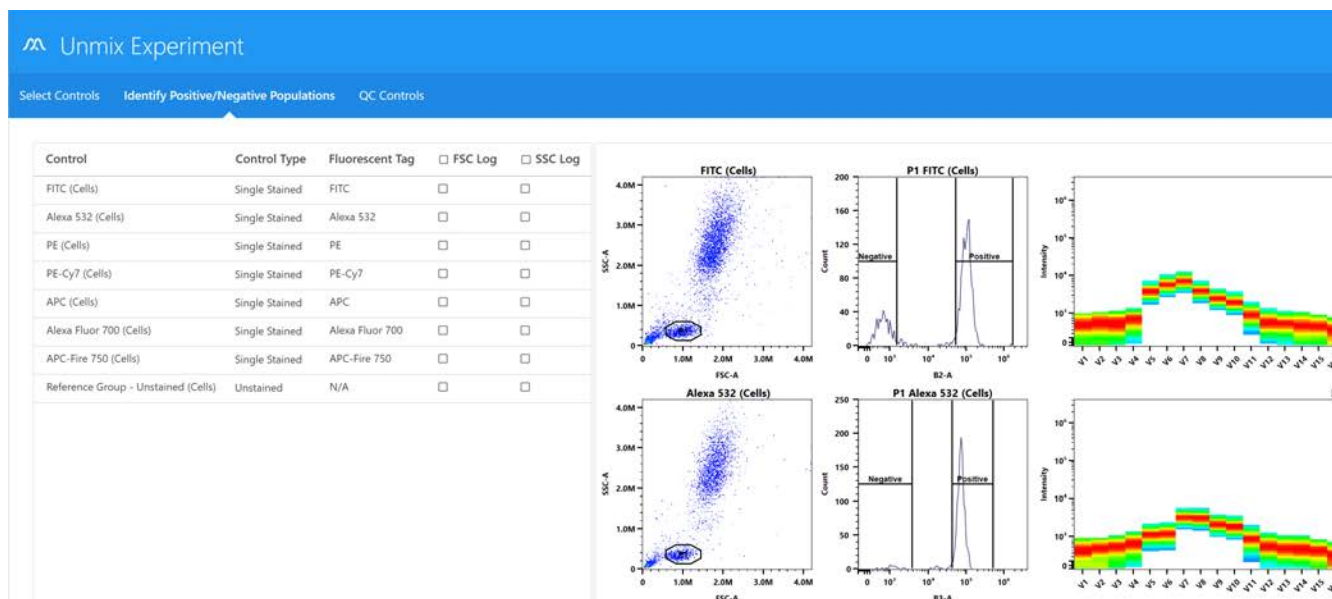

- 3 Click Create New Unmixed Experiment.

A new experiment opens with a new unmixed worksheet.

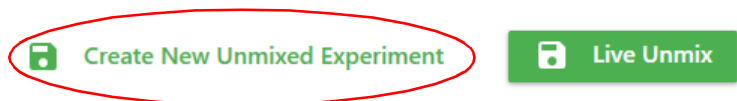

Use My Experiments to open experiments you ran, if you wish to review the data or acquire more samples.

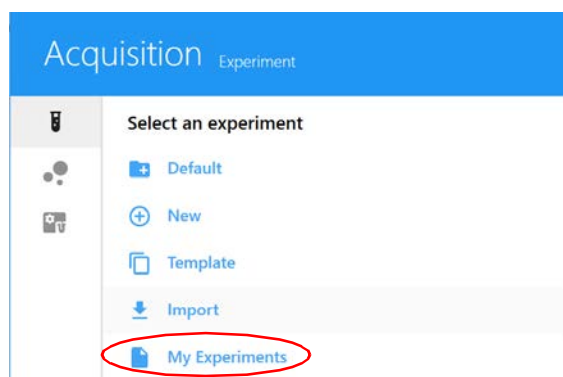

FCS files are stored in the Export folder by default, or the folder you set as the default. See [“Storage Preferences” on page 78](#) for information. FCS files for post-acquisition unmixed data are saved as unmixed data only.

Post Acquisition Unmixing in the Extra Tools Module

When performing post-acquisition unmixing in the Extra Tools module, you can pick and choose which FCS files to unmix (for example, controls coming from different experiments, reference controls run during QC & Setup, or single-stained controls that were not run as part of the reference group).

FCS files can be designated into three categories:

- Single Stained
- Unstained
- Sample

■ **NOTE:** There must be at least one single-stained FCS file and one unstained FCS file in the file list. Otherwise, unmixing cannot be performed.

■ **NOTE:** The parameters need to match in order for this to work.

In addition, raw FCS files can also be conventionally compensated in this module through the Virtual Filters tab. This function can simulate the presence of filters and can compensate data using conventional compensation methods (see “Virtual Filters” on page 102).

To Unmix Raw Data Files:

- 1 Select Spectral Unmixing from the Extra Tools module.
- 2 Click Import to import raw FCS files for unmixing.

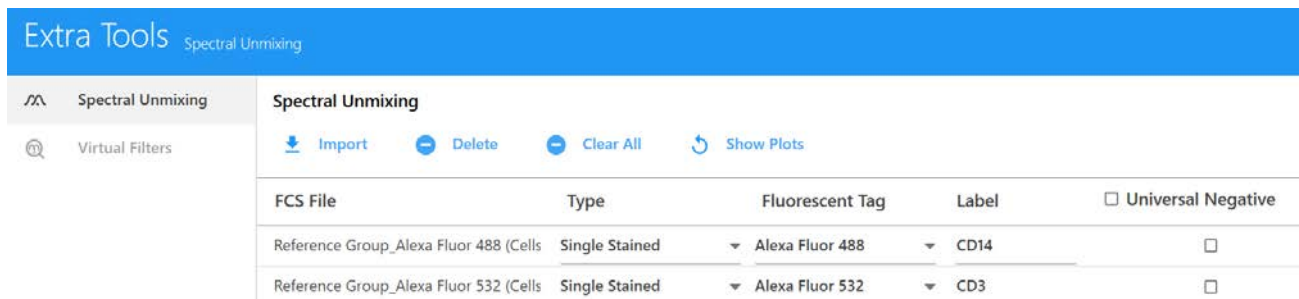

- 3 Select the files. Select multiple files using either the Shift or Ctrl key. Click **Open**.
- 4 Upon importing, a dialog box on how to assign sample types appears. Read the instructions and click OK.

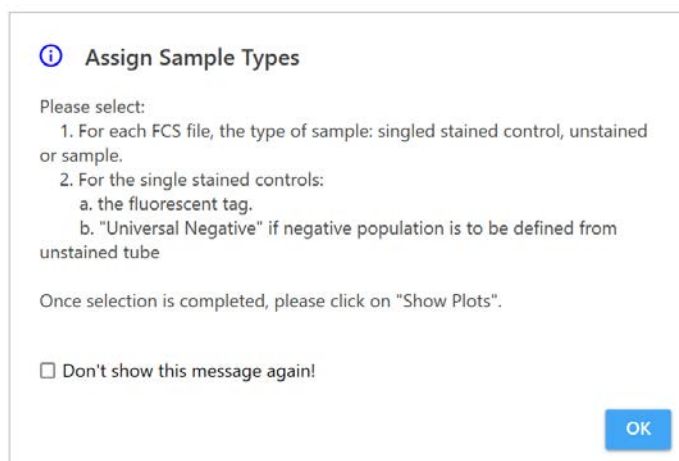

- Once FCS files have been imported, select the sample type for each FCS file as Single Stained, Unstained, or Sample. The software will automatically designate the type based upon the file name. You can manually modify these if the automatic designation is incorrect.

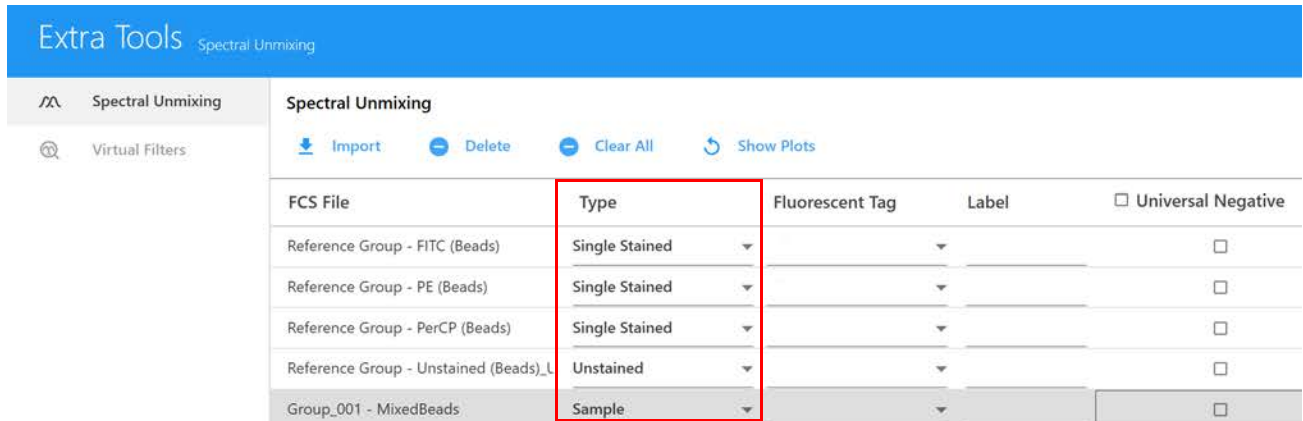

- FCS files designated as single-stained will require a fluorescent tag designation to specify what reference spectrum will be provided for unmixing.

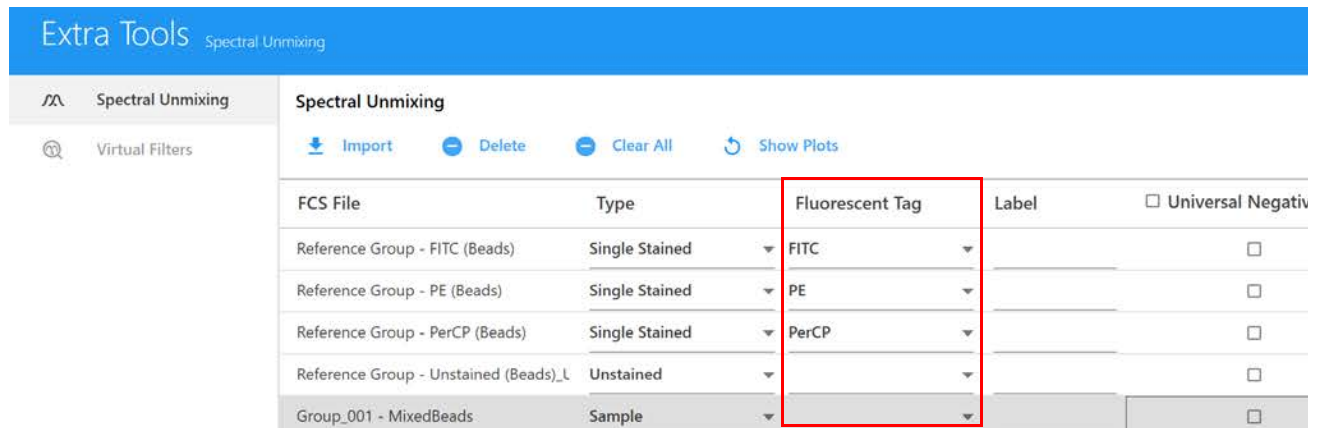

- Enter a label for each single-stained control and sample.

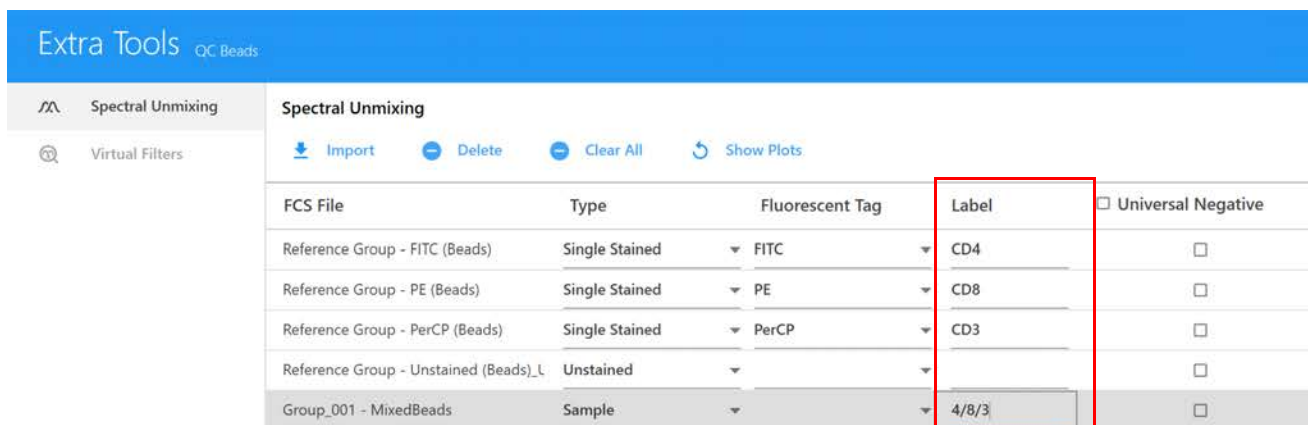

- Select Universal Negative for single-stained FCS files that do not contain a negative population, and the unstained control will be used for the negative population. In the bottom left of the screen, check whether Auto Fluorescence will be used as a fluorescent tag.

- 9 Click Show Plots to display the data in the FSC vs SSC plot, peak emission channel histogram, and spectrum plots.
- 10 The positive and negative populations need to be identified through the appropriate placement of the existing gates. Click OK to adjust the gates.
 - a. Move the polygon gate in the FSC vs SSC plot to include the singlet population.
 - b. Move the interval gate in the histogram labeled *Positive* to include the positively stained population. Move the interval gate in the histogram labeled *Negative* to include the negative population. Do not adjust the negative gate when using the Universal Negative.
 - c. Move the interval gate on the spectrum plot on the right to select the channel that exhibits the brightest fluorescence intensity. This channel is the peak emission channel for the fluorescent tag.

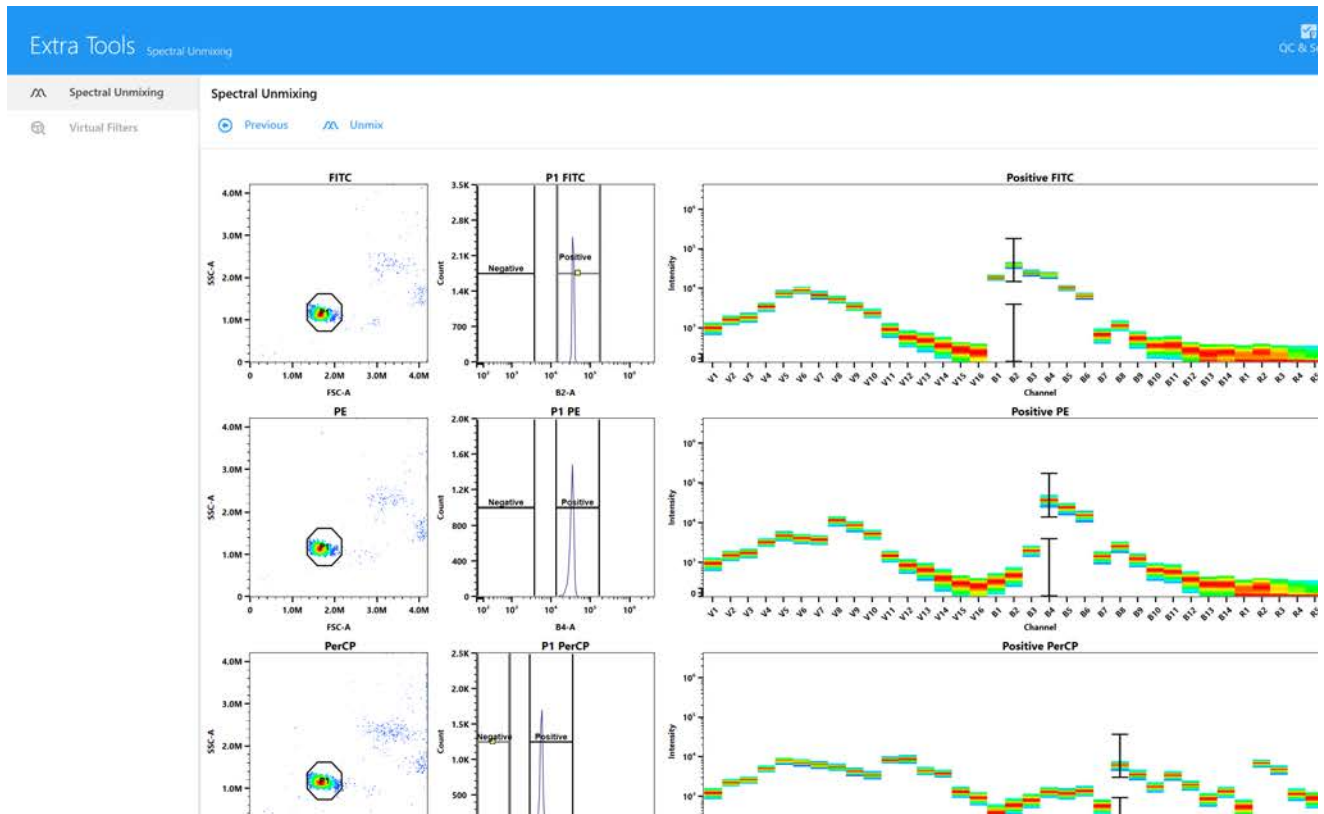

- 11 Click Unmix.
- 12 Select the directory to which the unmixed FCS files are exported or leave the default. Click OK.

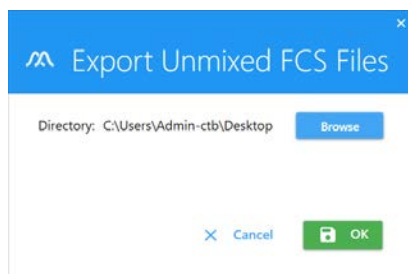

These FCS files can then be imported to an experiment for analysis or analyzed using third-party software.

Adjusting Spillover

You can adjust the fluorescence spillover for a selected tube/well.

- 1 Ensure the green arrow is next to the tube/well and right click, then select Edit Properties in the group-tube hierarchy list.

The Tube/Well Properties window opens.

- 2 Select the Spillover tab.

- 3 Click the Enable Compensation checkbox to activate. The Adjust Spillover icon in the toolbar is now enabled.

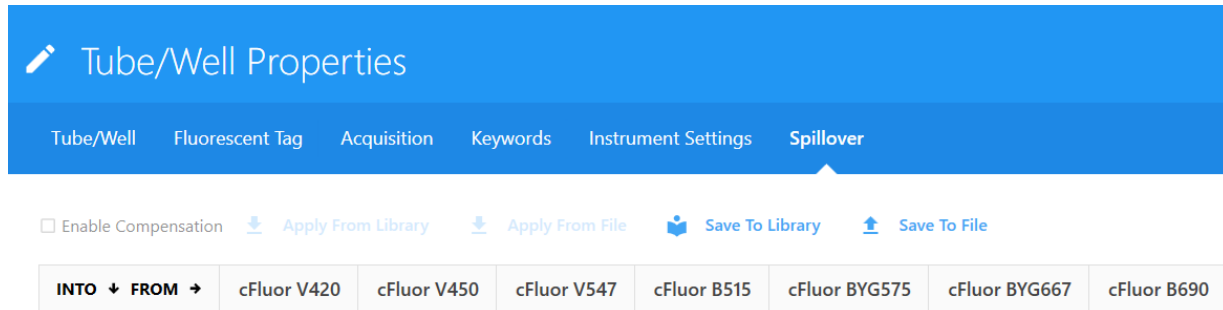

- 4 Leaving the Tube/Well Properties window open, click the Adjust Spillover icon $\begin{bmatrix} 10 \\ 01 \end{bmatrix}$, then click and drag in the plot in the direction you want to adjust.

Changes are reflected in Tube/Well Properties window.

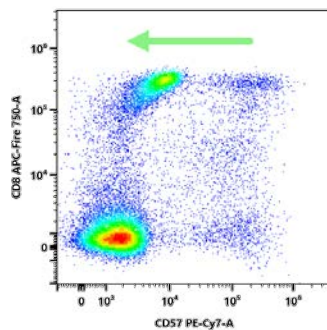

- 5 Click Save to save the changes. To discard the changes, close the Tube/Well Properties window and click No in the confirmation window, or click Discard changes in the tube/well properties window.

Virtual Filters

The Virtual Filters option in the Extra Tools module allows you to compensate raw FCS data using conventional compensation methods.

- 1 Click the Virtual Filters tab in the Extra Tools module.

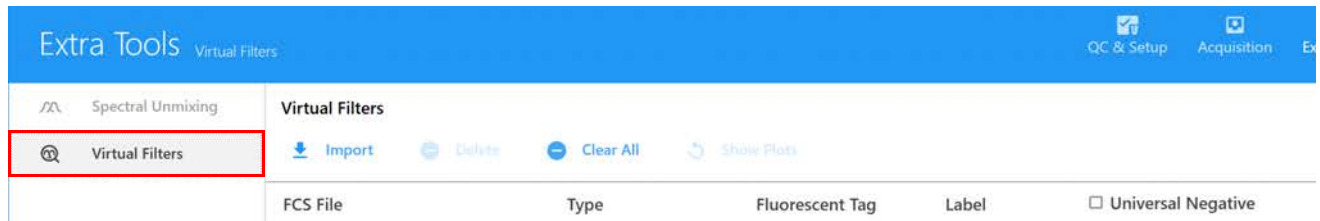

- 2 Click Import to import raw FCS files for virtual filter analysis.

These FCS files can be single-stained reference controls, unstained controls, and/or sample files. However, you must include an unstained control FCS file.

- 3 Upon importing, a dialog box on how to assign sample types appears. Read the instructions and click OK.

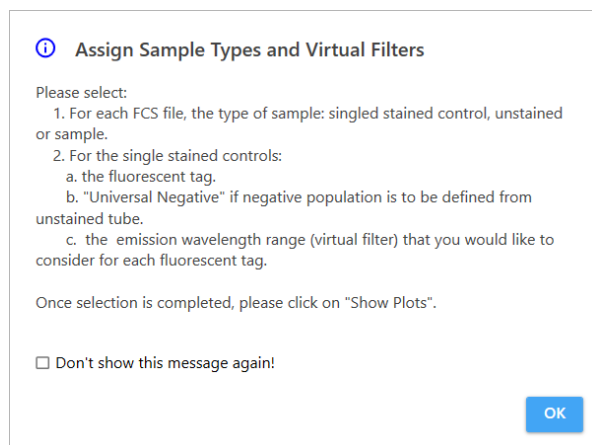

- 4 Once FCS files have been imported, the sample type for each FCS file needs to be designated as Single Stained, Unstained, or Sample. The software will automatically designate the type based upon the file name. You can manually modify these if the automatic designation is incorrect.
- 5 FCS files designated as single stained require a fluorescent tag designation. Select the fluorescent tag for each single-stained sample.

If there is no negative population in the single-stained FCS file(s), select Universal Negative, and the unstained control will be used for the negative population.

The virtual filter is automatically assigned by the software based upon the fluorescent tag designation. (Optional) To increase the bandwidth of the virtual filter, use the channel pull-down menus to select the desired range. See the following table for wavelength ranges.

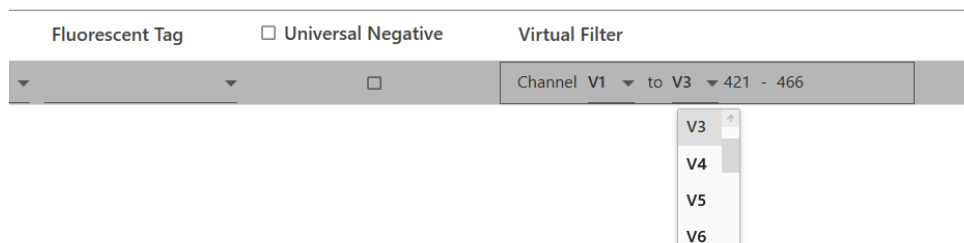

The following table shows the system's filter bandwidths.

Laser	Channel	Center Wavelength (nm)	Bandwidth (nm)	Wavelength Start (nm)	Wavelength End (nm)
Violet	V1	428	15	420	435
	V2	443	15	436	451
	V3	458	15	451	466
	V4	473	15	466	481
	V5	508	20	498	518
	V6	525	17	516	533
	V7	542	17	533	550
	V8	581	19	571	590
	V9	598	20	588	608
	V10	615	20	605	625
	V11	664	27	651	678
	V12	692	28	678	706
	V13	720	29	706	735
	V14	750	30	735	765
	V15	780	30	765	795
	V16	812	34	795	829
Blue	B1	508	20	498	518
	B2	525	17	516	533
	B3	542	17	533	550
	B4	581	19	571	590
	B5	598	20	588	608
	B6	615	20	605	625
	B7	661	17	653	670
	B8	679	18	670	688
	B9	697	19	688	707
	B10	717	20	707	727
	B11	738	21	728	749
	B12	760	23	749	772
	B13	783	23	772	795
	B14	812	34	795	829
Red	R1	661	17	653	670
	R2	679	18	670	688
	R3	697	19	688	707
	R4	717	20	707	727
	R5	738	21	728	749
	R6	760	23	749	772
	R7	783	23	772	795
	R8	812	34	795	829

6 (Optional) Select a label for the single-stained controls and samples.

7 Click Show Plots to display the plots.

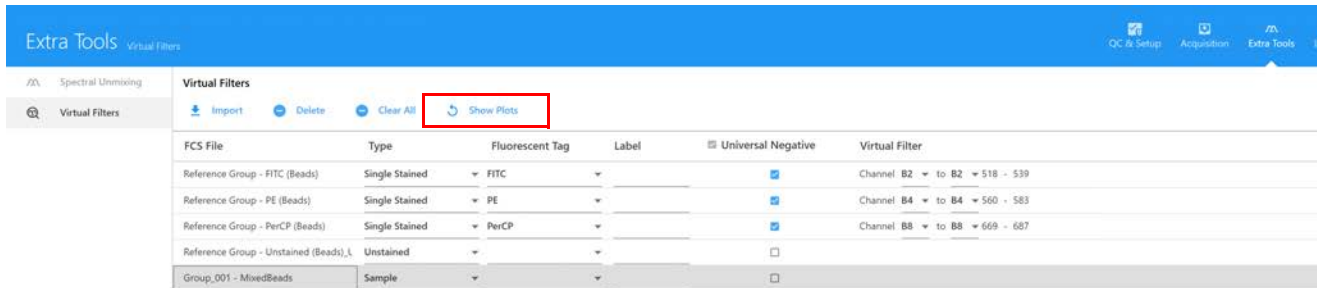

The data is displayed in the FSC vs SSC plot and fluorescent tag histogram plot.

- 8 The positive and negative populations need to be identified through the appropriate placement of the gates. Click OK to adjust the gates.
- a. Move the polygon gate in the FSC vs SSC plot to include the singlet population. Hold down Ctrl to move all the polygon gates at once.
 - b. Move the interval gate in the histogram labeled *Positive* to include the positively stained population. Move the interval gate in the histogram labeled *Negative* to include the negative population. Do not adjust the negative gate when using the Universal Negative.

The histogram x-axes are labeled with the fluorescent tag instead of the channel/detector.

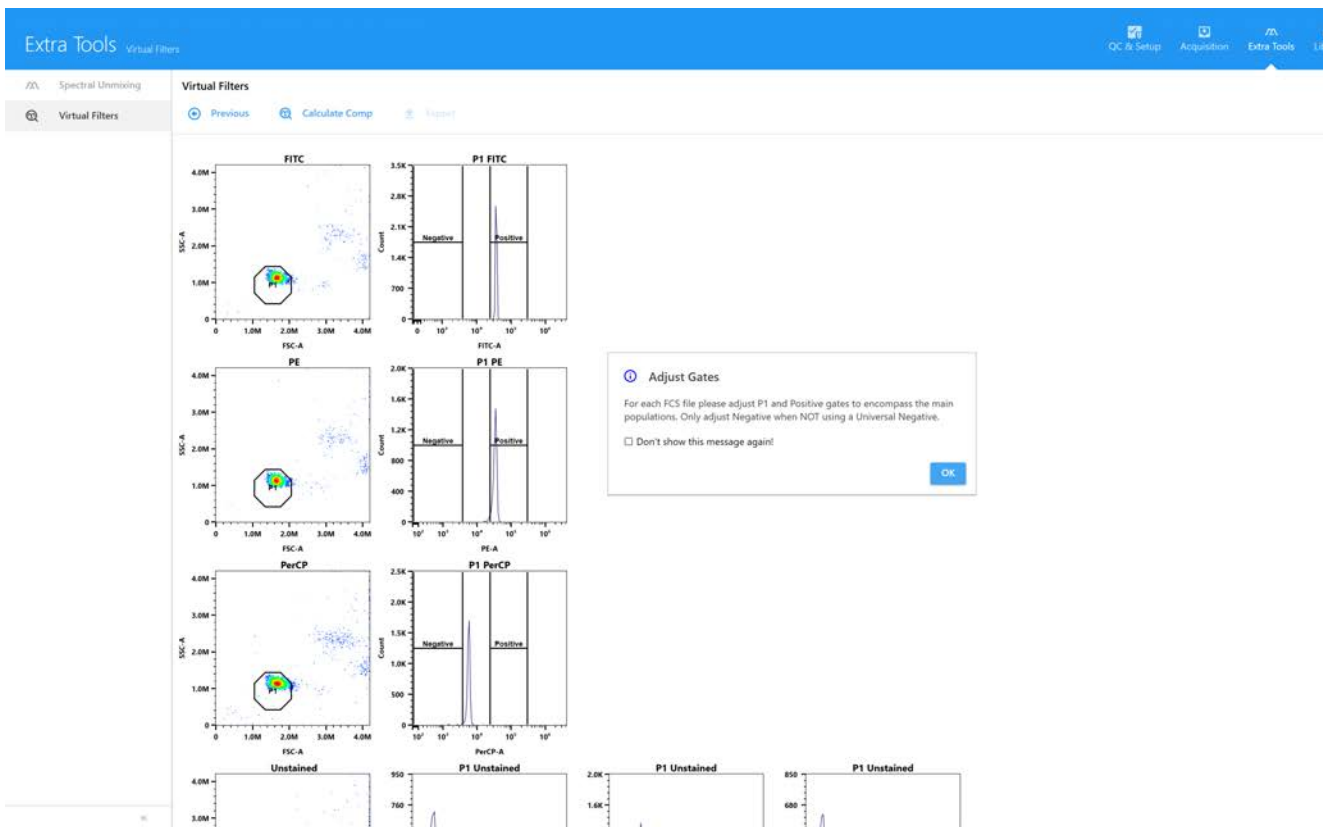

- Click Calculate Comp once gates have been set correctly. The conventionally compensated data is displayed. To view the data for a specific FCS files, select the file.

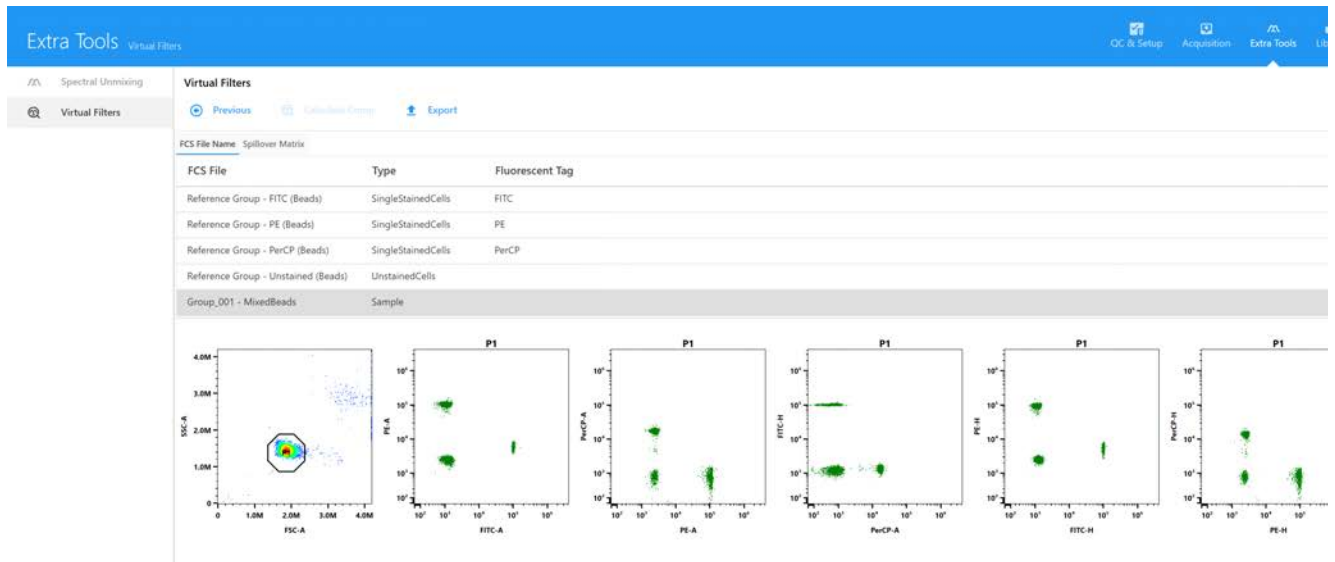

The spillover matrix is also calculated. Click Spillover Matrix to view the spillover values.

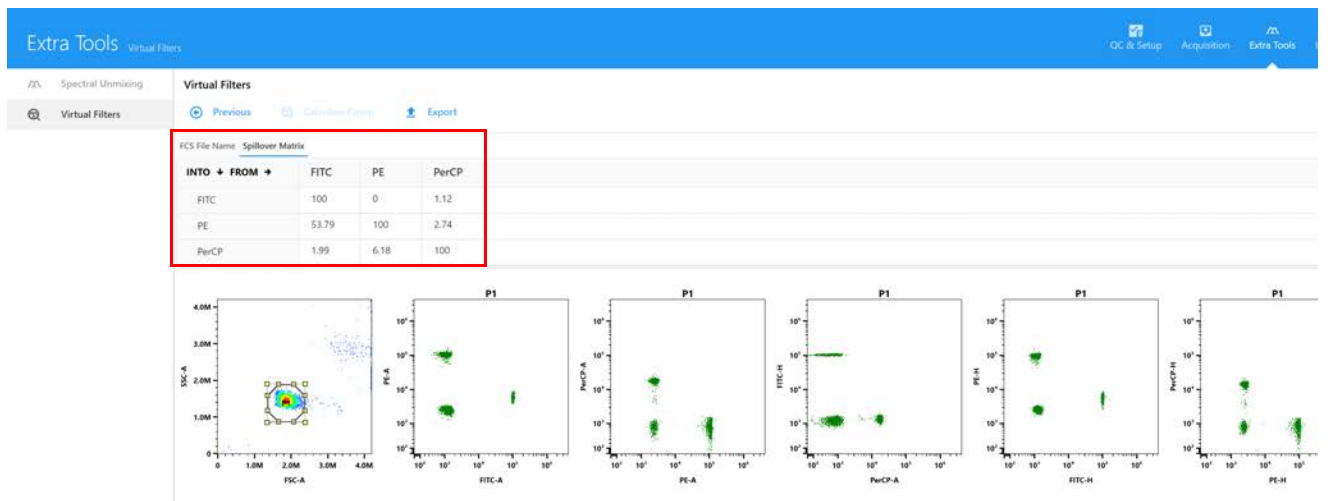

- Click Export and select the location where you wish to export the conventionally compensated data. The files are exported to a folder named Compensated followed by the current date and time. Files can then be imported back into an experiment to analyze in SpectroFlo software.

Worklist

Create or open a worklist

- 1 In the Worklist module, click New in the toolbar to create a new worklist. The existing worklists are displayed below the Worklist toolbar.
- 2 Select a desired Worklist and double-click, or click Open at the bottom to open the worklist.

The screenshot displays the 'Worklist' module interface. At the top, there is a blue header with the text 'Worklist' and a smaller 'Worklist' below it. Below the header is a toolbar with three buttons: 'Import' (with a download icon), 'Export' (with an upload icon), and 'New' (with a plus icon). Below the toolbar, there are three worklist entries, each in a white box with a light gray border. Each entry displays the following information:

Worklist ID	Created By	Date Created	Date Modified	Action
TNBK001	Admin	June 09, 2021 - 10:16 AM	June 10, 2021 - 09:35 AM	Open >
Worklist_002	Admin	June 09, 2021 - 09:47 AM	June 09, 2021 - 10:07 AM	Open >
Worklist_001	Admin	June 08, 2021 - 16:38 PM	June 09, 2021 - 09:37 AM	Open >

Add tasks

After opening a worklist, click the Add button, or click the drop-down arrow in the Task column in the Worklist to add tasks.

No.	Sample ID	Task	Status	Signed By
1		Daily QC		
1.1		QC Tube (2002)		
2	Sample_001	7C TBNK MT	To Be Acquired	
2.1		7C B		
3	Sample_002	7C TBNK MT	To Be Acquired	
3.1		7C B		
4		Fluidics Shutdown		
4.1		Fluidics Shutdown Tube 1		
4.2		Fluidics Shutdown Tube 2		
4.3		Fluidics Shutdown Tube 3		
4.4		Fluidics Shutdown Tube 4		

- 1 Click Add to bring up the Add Task dialog box.
- 2 Select the Assay Task or Fluidics Task you want to add.

Sample ID Start With: Start number of Sample ID:

Assay Task	Carrier	Created By	Date Created	Description
7C TBNK MT	Manual Tube	Admin	June 22, 2021 - 14:48 PM	CytekAssaySetting
7C B MT	Manual Tube	Admin	June 22, 2021 - 14:44 PM	WB-LNW setting, Preview 10S, Med Flow rate
6C B TR	40 Tube Rack	Admin	June 16, 2021 - 00:01 AM	10S delay, Med Rate, 3000 Lym, 15 uL
6C B MT	Manual Tube	Admin	June 15, 2021 - 23:40 PM	Mid Rate Manual

Fluidics Task	Description
<input checked="" type="checkbox"/> Daily QC	Daily QC
<input type="checkbox"/> SIT Flush	SIT Flush
<input type="checkbox"/> Clean Flow Cell	Clean Flow Cell
<input type="checkbox"/> Fluidics Shutdown	Fluidics Shutdown

- 3 Enter the required number of samples in the quantity box in the lower right corner, and click the Add button.
- 4 When finished, click the Close button to close the dialog box.

Note that some fluidic tasks can only be added to specific carrier types. When adding a task, the software will automatically select the sample carrier required for the test and perform the default sample position layout on the carrier.

- 5 (Optional) Print the Tube/well location table. Click on Print and select Print Tube/Well Location Mapping Table.

Reference controls

You can choose to use the reference controls saved in the library or create reference controls in the worklist.

- 1 Click Ref Controls and the Create Reference Control dialog box will pop up. The software will generate a reference control list according to the Assays added to the Worklist.
- **NOTE:** The Ref Controls icon will be grayed out until you add the assay you will be running.
- 2 Click the Add button to add additional reference controls.

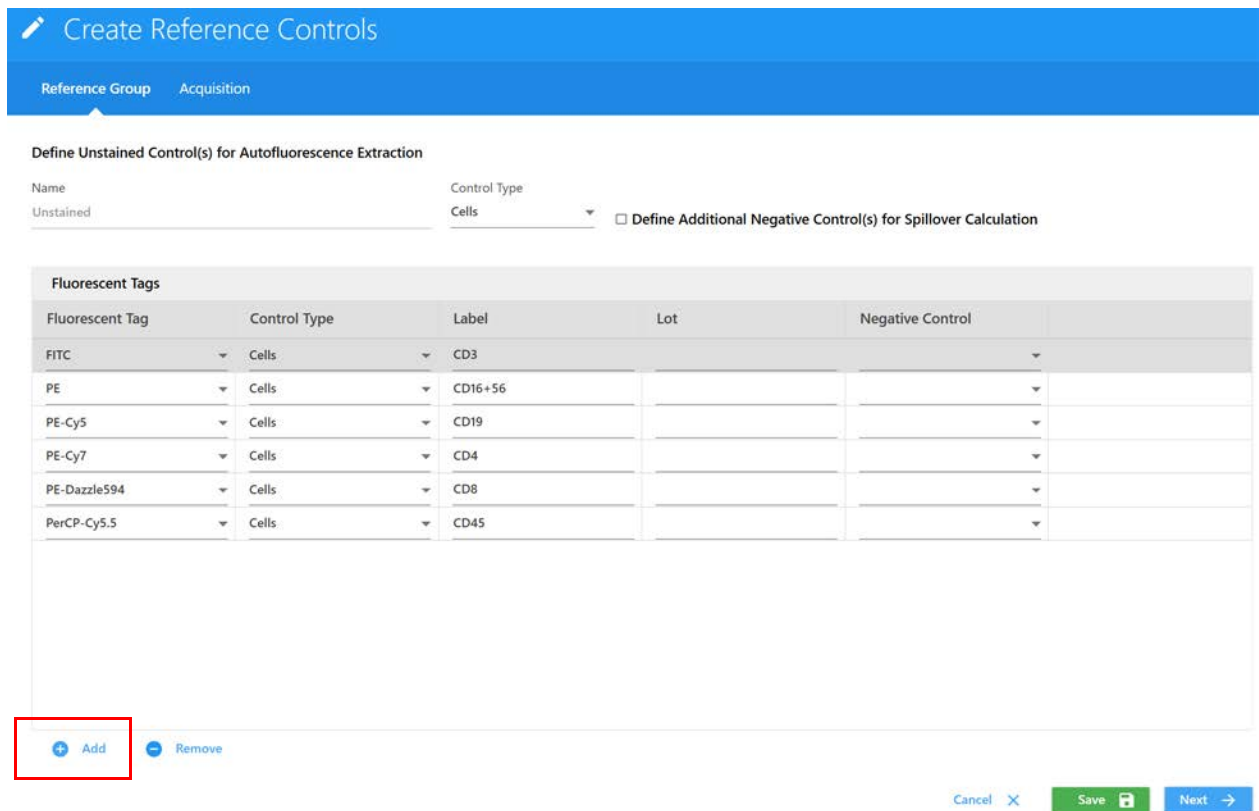

Create Reference Controls

Reference Group Acquisition

Define Unstained Control(s) for Autofluorescence Extraction

Name: Unstained Control Type: Cells Define Additional Negative Control(s) for Spillover Calculation

Fluorescent Tag	Control Type	Label	Lot	Negative Control
FITC	Cells	CD3		
PE	Cells	CD16+56		
PE-Cy5	Cells	CD19		
PE-Cy7	Cells	CD4		
PE-Dazzle594	Cells	CD8		
PerCP-Cy5.5	Cells	CD45		

+ Add - Remove

Cancel X Save Next →

- 3 Click Acquisition or click Next to select worksheet, stopping criteria, and instrument setting for data collection.

If multiple assays in the Worklist use different user settings, all user setting plus CytekAssySetting will be listed in the drop-down menu.

CytekAssySetting will always be the default setting. The reference control data should be collected before the sample data.

Create Reference Controls

Reference Group Acquisition

User Setting: 6CB

Name	CytekAssySetting (Cytek)	Sheet	Stopping Gate	Storage Gate	Events To Record	Stopping Volume (ul)	Stopping Criteria
Reference Group	6CB	Raw Worksheet (Raw)	All Events	All Events	5,000	3,000	<input type="checkbox"/> Count & Volume
Unstained (Cells)	Default Raw Worksheet (Raw)	Raw Worksheet (Raw)	All Events	All Events	5,000	3,000	<input type="checkbox"/> Count & Volume
CD45 FITC (Cells)	Default Raw Worksheet (Raw)	Raw Worksheet (Raw)	All Events	All Events	5,000	3,000	<input type="checkbox"/> Count & Volume
CD56 PE (Cells)	Default Raw Worksheet (Raw)	Raw Worksheet (Raw)	All Events	All Events	5,000	3,000	<input type="checkbox"/> Count & Volume
CD8 PE-Dazzle594 (Cells)	Default Raw Worksheet (Raw)	Raw Worksheet (Raw)	All Events	All Events	5,000	3,000	<input type="checkbox"/> Count & Volume
PE-Dazzle594 (Cells)	Default Raw Worksheet (Raw)	Raw Worksheet (Raw)	All Events	All Events	5,000	3,000	<input type="checkbox"/> Count & Volume
CD19 PE-Cy5 (Cells)	Default Raw Worksheet (Raw)	Raw Worksheet (Raw)	All Events	All Events	5,000	3,000	<input type="checkbox"/> Count & Volume
PE-Cy5 (Cells)	Default Raw Worksheet (Raw)	Raw Worksheet (Raw)	All Events	All Events	5,000	3,000	<input type="checkbox"/> Count & Volume
CD3 PerCP-Cy5.5 (Cells)	Default Raw Worksheet (Raw)	Raw Worksheet (Raw)	All Events	All Events	5,000	3,000	<input type="checkbox"/> Count & Volume
CD4 PE-Cy7 (Cells)	Default Raw Worksheet (Raw)	Raw Worksheet (Raw)	All Events	All Events	5,000	3,000	<input type="checkbox"/> Count & Volume
APC (Cells)	Default Raw Worksheet (Raw)	Raw Worksheet (Raw)	All Events	All Events	5,000	3,000	<input type="checkbox"/> Count & Volume
CD19 APC (Cells)	Default Raw Worksheet (Raw)	Raw Worksheet (Raw)	All Events	All Events	5,000	3,000	<input type="checkbox"/> Count & Volume
APC-Cy7 (Cells)	Default Raw Worksheet (Raw)	Raw Worksheet (Raw)	All Events	All Events	5,000	3,000	<input type="checkbox"/> Count & Volume
CD8 APC-Cy7 (Cells)	Default Raw Worksheet (Raw)	Raw Worksheet (Raw)	All Events	All Events	5,000	3,000	<input type="checkbox"/> Count & Volume

Unmix

The Unmix process is the same as that in Experiment. See “Unmixing Workflows” on page 90 for details.

- 1 Click Unmix and select the corresponding reference control and whether to use autofluorescence extraction

2 Click Live Unmix.

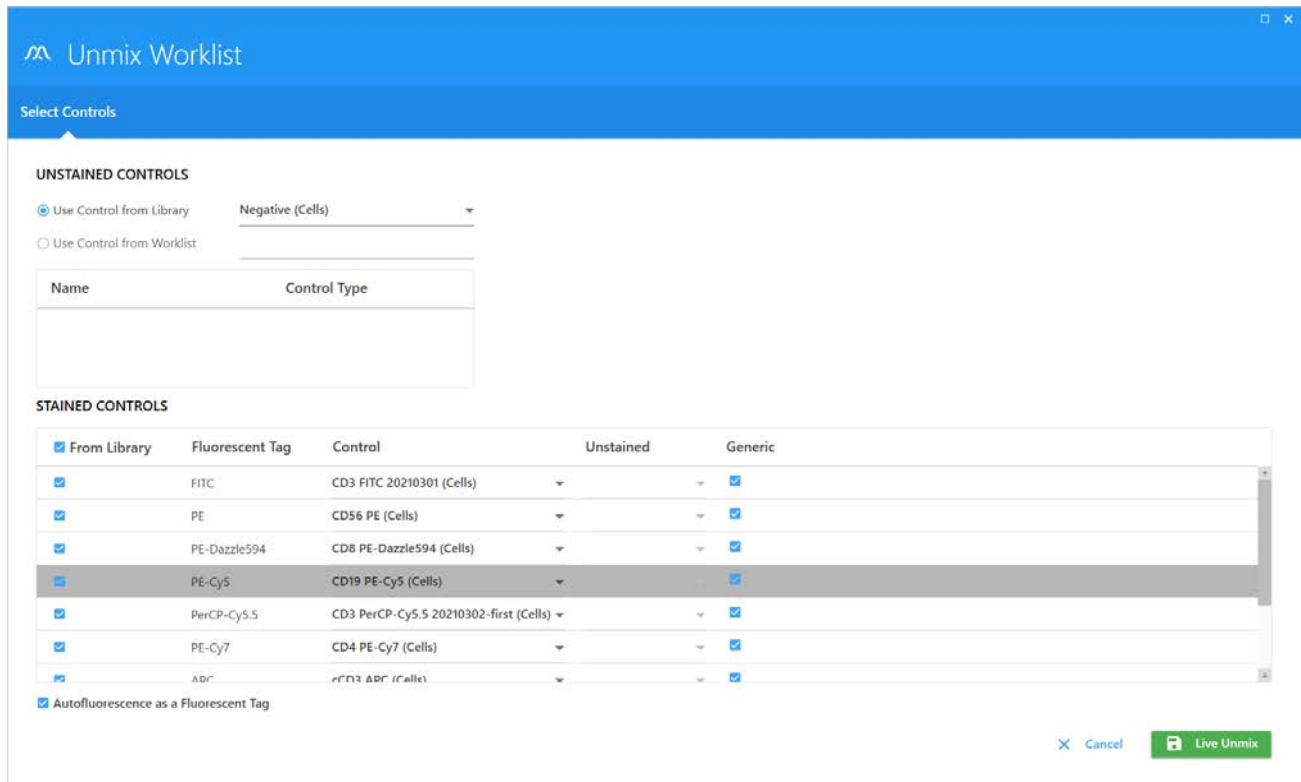

Lot specific reference controls

You can select lot specific reference controls.

- 1 Click Control Lot to bring up the Reference control lot selection window.
- 2 If the same Fluorochrome has a different lot number, you can select a specific lot number in the drop-down menu. Not Specified Fluorochrome will use the default best fit reference control determined by the software.

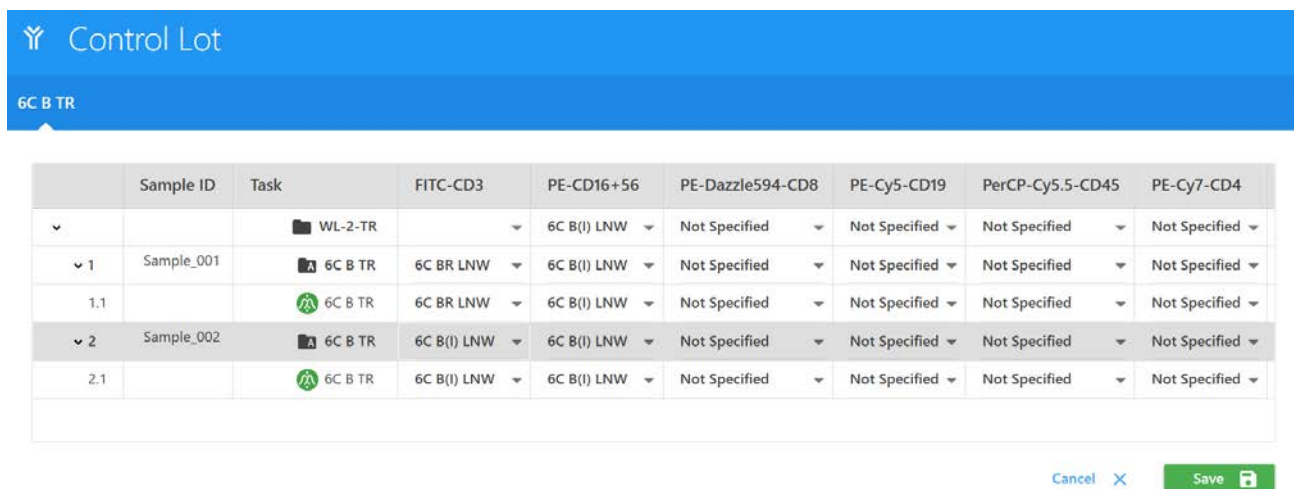

Arrange sample locations in a carrier

Assays that contain carrier type cannot be changed in the Worklist, except assays that use Tube rack, which can be changed to manual in Worklist.

- 1 Click the Options button in the tool bar to open the sample carrier options dialog box.
 - You can change the sample carrier type (manual/Tube rack) if an assay uses the Tube rack.
 - You can customize sample tube/well locations on a carrier by drag and drop.

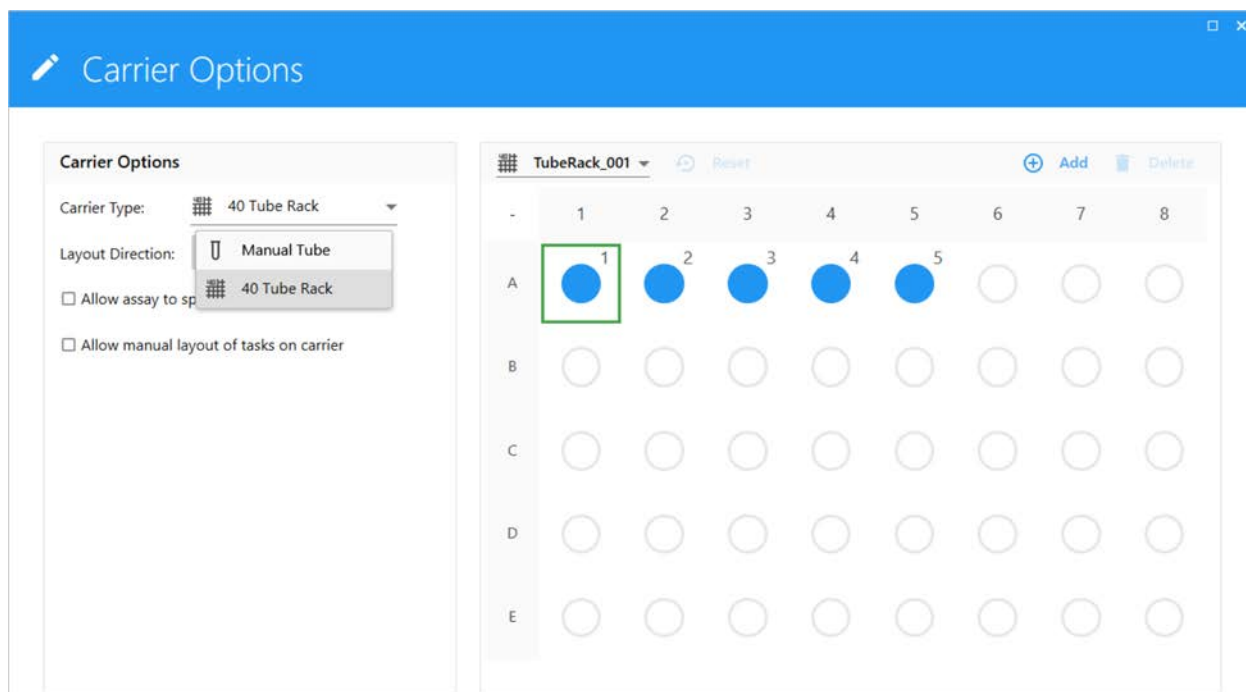

Data collection

- 1 Double-click an entry or a tube in the Worklist to make it the current task.
- 2 Click the Start button in the Acquisition Control panel and observe the scatter plot in the data display area on the right.
- 3 Adjust the FSC and/or SSC gain and Threshold in the instrument control pane to put the population of interest on scale. Adjust the gate in the FSC vs SSC plot to enclose the population.

- Click the Run button, and in the pop-up drop-down list, select the sample range to be collected to start the data collection. The software will prompt you to load the correct sample tube or Carrier type.

Worklist_003

No.	Sample ID	Task	Location	Carrier	Status
1	Sample_001	6C B TR	A1		To Be Acquired
1.1		6C B TR	A1	TubeRack_001	
2	Sample_002	6C B TR	A2		To Be Acquired
2.1		6C B TR	A2	TubeRack_001	
3	Sample_003	6C B TR	A3		To Be Acquired
3.1		6C B TR	A3	TubeRack_001	
4	Sample_004	6C B TR	A4		To Be Acquired
4.1		6C B TR	A4	TubeRack_001	

Acquisition Control

6C B TR: Not Ready - Warming up

Flow Rate: Medium uL/Min: 0.00

Event Rate: 0 Abort Rate: 0

Threshold Count: 0

Time Elapsed: 00:00:00 (HH:MM:SS)

Events to Display: 5,000

Selection	Description
Run Current	Record data for current tube/well
Run Entry	Record data for current entry
Run From Entry	Start record data for the worklist from current entry
Run From Current	Start record data for the worklist from current tube/well
Run All	Start record data for the whole worklist from the first entry

Export Report

- Double-click an entry that has been recorded, and the report will be opened on the right side. The report enables you to preview the data for the following items: gating and unmixing accuracy, modify the report, add notes, approve and export reports.

Correct Unmix errors

If a worksheet or report was used for acquisition it is possible to modify compensation, if needed.

- 1 Right-click on a tube/well to and select Properties.
- 2 Go to the Spillover tab.
- 3 Adjust compensation and click Save.
- 4 The software will prompt you to select if you want to apply the compensation changes to other samples.

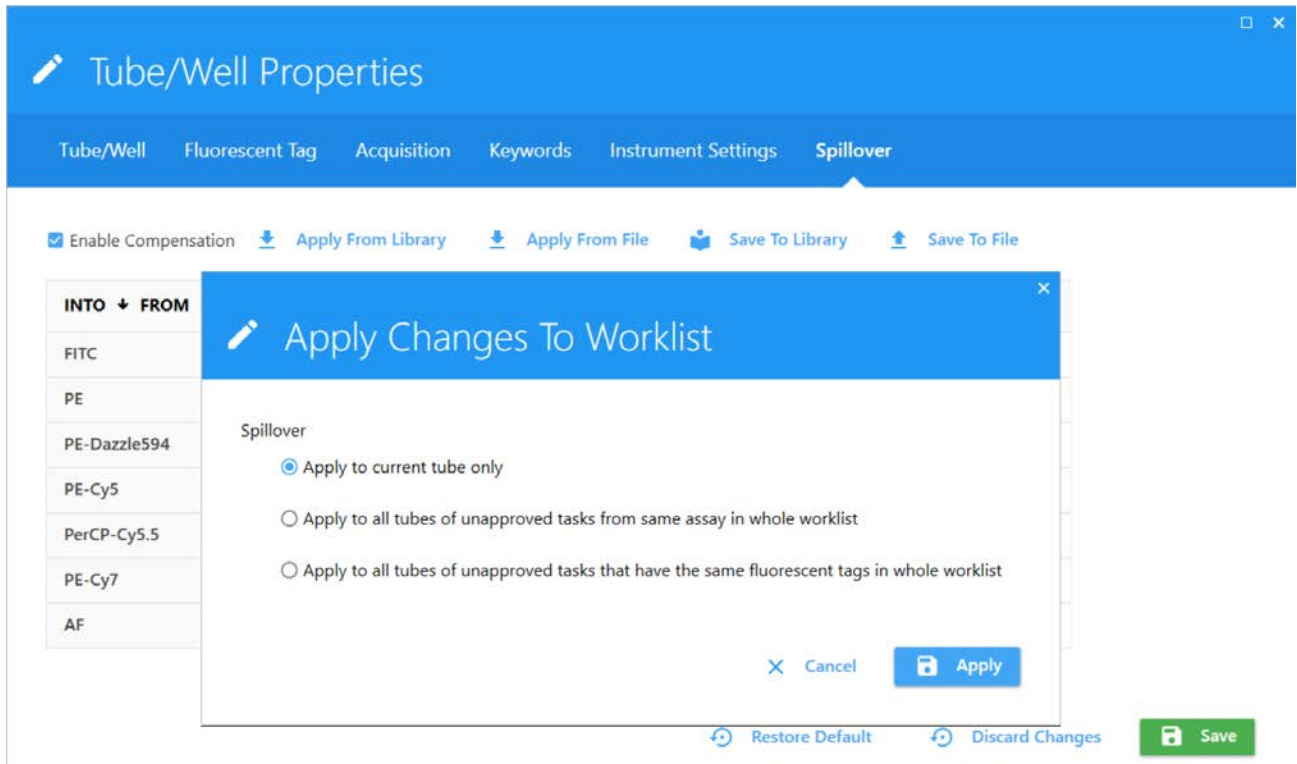

Modify Report

The components on a Report cannot be added or removed but the gates can be adjusted according to the data.

- 1 After the adjustment is completed for one entry, you can right-click on the entry (sample) to apply the adjustment to other samples in the worklist.

The screenshot displays the 'Worklist' software interface. At the top, there's a blue header with 'Worklist' and 'Worklist Entries'. Below it, a toolbar contains icons for 'Add', 'Ref Controls', 'Unmix', 'Control Lot', 'Options', 'Approve All', 'Export CSV', 'Export PDF', and 'Print'. The main area is a table with columns: 'No.', 'Sample ID', 'Task', 'Status', and 'Sign'. The table lists several tasks, including 'CD8 PE-Dazzle594 (Cells)', 'CD19 PE-Cy5 (Cells)', 'CD45 PerCP-Cy5.5 (Cells)', and 'CD4 PE-Cy7 (Cells)'. A sample entry 'Sample_001' with task '6CB' is highlighted, and a context menu is open over it. The menu options are: 'Insert Task(s)', 'Delete', 'Run Selected', 'Run All', 'Paste Spillover', 'Apply Report' (which is expanded to show 'Apply changes in "Report_001" to other tasks'), 'Approve', and 'Unapprove'. To the right, there's a plot titled 'All Events' showing 'SSC-A' vs 'FSC-A' with a gate labeled 'P1'. Below the plot is an 'Acquisition Control' panel with buttons for 'Start', 'Run', 'Stop', 'Pause', and 'Restart', along with 'Flow Rate: Low' and 'uL/Min: 18.84'.

Audit trail

The software will automatically record the key operations and manual changes in the audit trail log.

- 1 Click the Audit Trail Logs button to open the Audit Trail Logs dialog box.

The screenshot shows the software's main navigation bar with buttons for 'QC & Setup', 'Acquisition', 'Worklist', 'Extra Tools', 'Library', 'Preferences', 'Users', 'Help', and 'Sign Out'. Below the navigation bar, the top status area displays 'TUBES 6C B TR(6C B TR)' and 'REPORTS 6C B TR'. On the right side of the status area, there are buttons for 'Approve' and 'Audit Trail Logs'.

2 In the audit trail log dialog box, you can enter the reasons in batches, or one by one.

Export All Audit Trail Logs

No.	Action	Reason	Operator	Date Created
2	6CBR			
	Unapproved by Administrator at June 11, 2021 - 13:15 PM.	Comments:	Administrator	June 11, 2021 - 13:15 PM
	Approved by Administrator at June 09, 2021 - 09:33 AM.	Signature Comments: test	Administrator	June 09, 2021 - 09:33 AM
	Unapproved by Administrator at June 09, 2021 - 09:32 AM.	Comments:	Administrator	June 09, 2021 - 09:32 AM
	Approved by Administrator at June 09, 2021 - 09:29 AM.	Signature Comments: test	Administrator	June 09, 2021 - 09:29 AM
	Modify Gate in Report: Report_001.		Administrator	June 09, 2021 - 09:29 AM
	Modify Gate in Report: Report_001.	Modify	✓ Administrator	June 09, 2021 - 09:29 AM
	Modify Gate in Report: Report_001.		Administrator	June 09, 2021 - 09:29 AM
	Modify Gate in Report: Report_001.		Administrator	June 09, 2021 - 09:29 AM
	Modify Gate in Report: Report_001.		Administrator	June 09, 2021 - 09:29 AM
	Modify Gate in Report: Report_001.		Administrator	June 09, 2021 - 09:29 AM
	Modify Gate in Report: Report_001.		Administrator	June 09, 2021 - 09:29 AM

Reason

Modify

Close

Approve Report

- 1 After report adjustment and review are completed, click the Approve button to approve the report.
- 2 The approval process will prompt for the user name and password of the approver, and allow comments.
- 3 After completion, the status of the test task will change to Approved.

- Click Approve All for batch approval after confirming that all reports are correct.

No.	Sample ID	Task	Location	Carrier	Status
1	Sample_001	6C B TR	A1		To Be Approved
1.1		6C B TR	A1	TubeRack_001	
2	Sample_002	6C B TR	A2		To Be Approved
2.1		6C B TR	A2	TubeRack_001	
3	Sample_003	6C B TR	A3		To Be Approved
3.1		6C B TR	A3	TubeRack_001	
4	Sample_004	6C B TR	A4		To Be Approved
4.1		6C B TR	A4	TubeRack_001	

- If you want to re-record or make changes in an approved report, click the Unapprove button.
- The entry status will change from approved to pending approval.
- You can re-record, or adjust the gates, etc., and re-approve the entry.

Print Report









After a report is approved, the PDF file of the report and CSV file of the data in statistical table will be automatically exported to C:\CytekbioExport_CLC\WorklistReportResults. You also can manually export PDF file and CSV file to a selected directory.



- To print Reports, click Print.
- Select the test report to be printed and the audit trail log to be included.

3 Follow the rest of the prompts to print.

 Print

<input checked="" type="checkbox"/>	No.	Task	Status	<input checked="" type="checkbox"/> Include Audit Trail Logs
<input checked="" type="checkbox"/>	1	▼  6C B TR	Approved	<input checked="" type="checkbox"/>
		 6C B TR		
<input checked="" type="checkbox"/>	2	▼  6C B TR	Approved	<input checked="" type="checkbox"/>
		 6C B TR		
<input checked="" type="checkbox"/>	3	▼  6C B TR	Approved	<input checked="" type="checkbox"/>
		 6C B TR		
<input checked="" type="checkbox"/>	4	▼  6C B TR	Approved	<input checked="" type="checkbox"/>
		 6C B TR		

[X Cancel](#) [Print Preview](#)

Loader Overview

The Automated Sample Loader (ASL) is an automated loading system that mixes samples and delivers tube racks and plates to the cytometer for acquisition. The Loader can be included as an option on a new system, or it can be ordered and installed at a later time by field service. The Loader offers consistent performance to meet application requirements.



The ASL resuspends samples using an orbital shaker. In addition to supporting a variety of 96-well plates, including deep-well plates, it supports a 40-tube rack. Loader settings are user-adjustable, including mixing speed, mixing duration, the number of SIT flushes between samples, and data record delay time. Loader settings are Default (standard), High throughput, and Low carryover.

Automated Sample Loader Components

The Loader power switch is located on the back of the loader. To power up the Loader, connect the power supply and turn the power switch to the ON position.

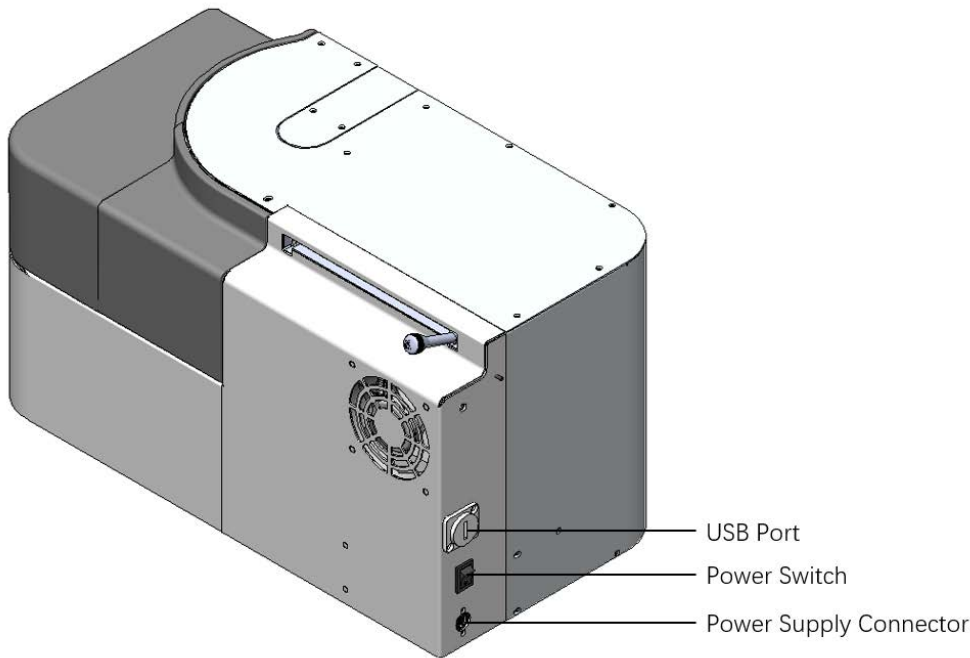

When the Loader is powered on and successfully connected to the software, the status indicator in the lower-right corner of the screen shows a green checkmark. A red X appears if the Loader is not powered on or not connected to the software.



- The right panel includes the main controls for the Loader. There is one USB Port, a power supply connector, and a power switch.

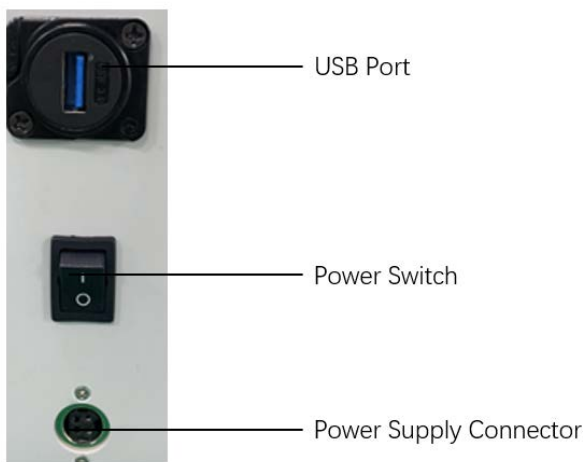

- The loader has 2 covers that can be opened to put the sample carrier onto the stage platform.
- The fan is located on the right side and is used for ventilation of the electronics. It comes on when the temp is above 27deg C.

- The software detects the position of the handle and will set the cytometer to function in the corresponding mode.

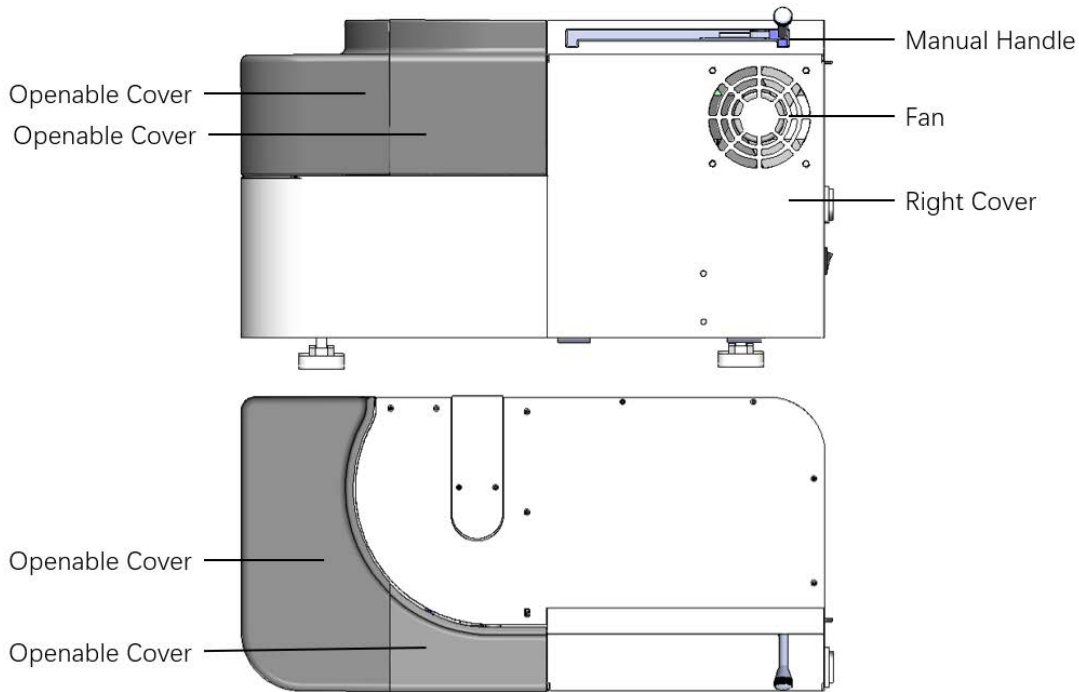

- The Manual Handle is located on the right side of the Loader. The handle is a mechanical lever used to make the instrument work in Plate Mode, Tube Mode, or Tube Rack Mode. The handle can be moved with either power on or power off.

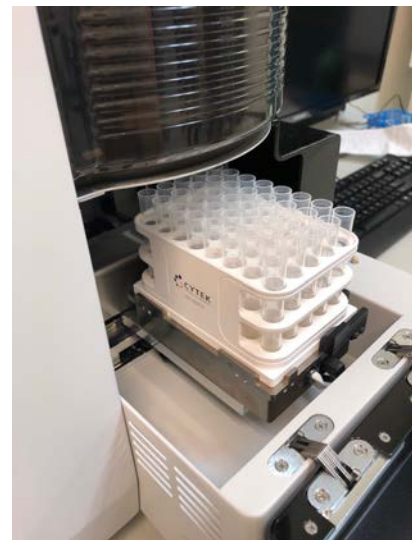
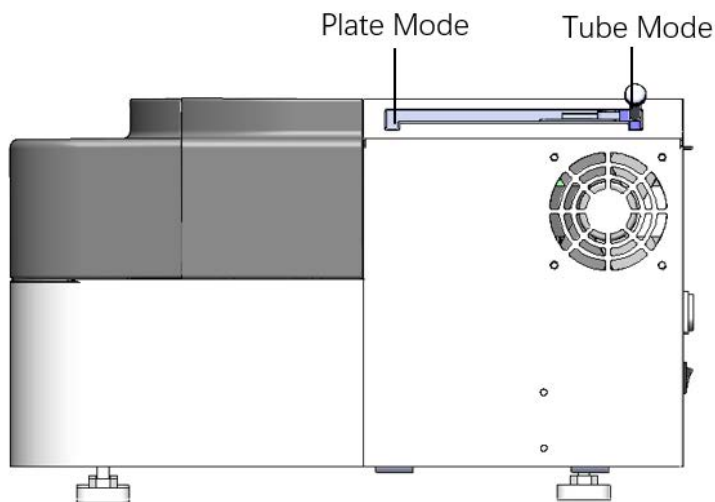

Loader Acquisition Controls and Settings

The Acquisition Control pane allows you to start, stop, and pause acquisition, record data, and restart acquisition counters. To show, hide, or undock (float) this pane from the experiment panel, use the dock/undock and hide icons in the top-right corner.

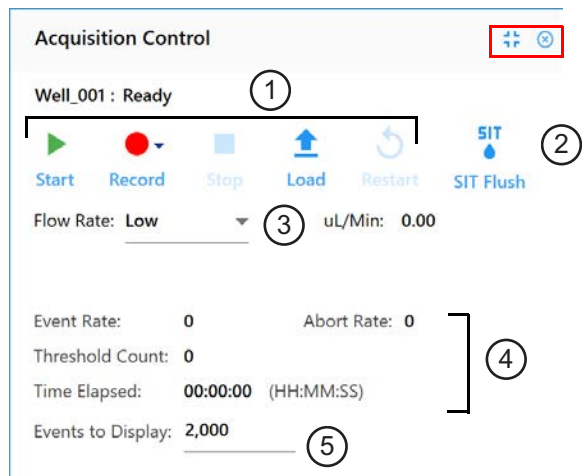

The following table describes the controls in the Acquisition Control pane.

No.	Control	Description
1	Start/Record/Stop/Load/Eject/Restart	It will depend on whether running a plate or running a tube rack. Running a plate: the lever is forward. Running a tube rack: the lever is to the back. Select Start after selecting Load plate to start acquisition. Select Record to record data. Record can also start acquisition. Select Stop to stop acquisition. Select Load or Eject to load or eject the plate. Select Restart to restart the acquisition counters. All events and results displayed are refreshed. Stop and Restart are enabled once Start is selected. Stop and Pause are enabled once Record is selected.
2	SIT Flush	Select to perform a SIT Flush
3	Flow Rate	Select Low (15 $\mu\text{L}/\text{min}$), Medium (30 $\mu\text{L}/\text{min}$), or High (100 $\mu\text{L}/\text{min}$). The exact flow rate is displayed.
4	Event Rate, Abort Rate, Threshold Count, Time Elapsed	Displays the real-time counts during acquisition.
5	Events to Display	Enter the number of events to display during acquisition.

The following table describes the ASL Loader settings.

Setting	Description
Selected Settings	Three Loader settings are available—default, high throughput, and low carryover. You can create your own custom settings.
Acquisition order	Select the order that you want the plate to run. Wells are acquired by: <ul style="list-style-type: none"> • row from left to right (A1-A12, B1-B12, etc.) • column from top to bottom (1A-1H, 2A-2H, etc.) • row from left to right, then right to left (A1-A12, B12-B1, C1-C12, etc.) • column from top to bottom, then bottom to top (1A-1H, 2H-2A, etc.)
Shake Time	Select the time (in seconds) to shake the plate/tube rack. You can also disable shake time.
Shake Speed	Select the speed of the orbital shaker (in RPM).
Shake Interval Mode	Select whether you would like to shake every N wells/tubes or after a specified period of time. You can also disable shaking.
Shake Every N Wells, or Shake Interval	Select how often (number of wells/tubes or time in seconds) to shake the plate/tube rack.
Premix Time	Select the time (in seconds) to shake the plate/tube rack before acquisition of the first tube/well.
SIT Flush Times	A SIT flush is performed over the wash station after each acquisition. Choose single flush, double flush, or disabled if you do not wish to perform a SIT flush.
Sample Recovery	Allows any remaining sample that is left in the SIT after acquisition is complete to be deposited back into the well.
Record Data Delay Time	Select the time in seconds you wish to preview data from a well/tube before recording begins once you click Record.

Loader Daily Workflow

The following section describes the recommended procedures for operating the Automated Sample Loader from start up to shut down.

Startup

- 1 Power on the cytometer, Loader, and computer (if not already powered up).
- 2 Launch the SpectroFlo software and login with the appropriate username.
- 3 Once logged into the software, the cytometer initialization procedure will begin. Load a tube of DI water and wait for the instrument and the Loader self-checking procedure to finish. The Cytometer and Loader connection status indicator will turn green when self-checking is complete.

- 4 Ensure that the status indicator checkmark for “Cytometer” and “Loader” are both green. This indicates that the workstation, instrument, and Loader are communicating with one another.



- 5 The Loader and Cytometer are now ready for use.

Set Up Experiment

Setting up the experiment in SpectroFlo includes:

- 1 Providing a name and description (optional) for the experiment.
- 2 Specifying the fluorophores used in the experiment.
- 3 Defining the reference group as either acquired in the experiment or referred from the stored reference control library.
- 4 Defining the acquisition criteria for reference group and sample group. Acquisition criteria is based on events, volume or time.
- 5 (optional) If the reference controls are to be acquired in the experiment, it CANNOT be live unmixed during acquisition. Acquisition must proceed with a raw worksheet. Reference controls that are referred to from the stored reference control library do not need to be acquired in the experiment.
- 6 Run the sample, adjust instrument setting, and save User Settings in the software.

Acquisition

The Acquisition workspace provides the user with the necessary elements for data collection. Flow cytometer data can be acquired from experiments. Experiments can be created either through the new experiment wizard or using experiment templates. SpectroFlo software includes many features that ensure the proper acquisition of flow cytometry data. Data is recorded into the FCS 3.0 format.

The Acquisition workspace provides an interface where the user can layout an experiment worksheet with different elements such as 2-D plots, histograms, and statistics displays. Instrument gain settings are also adjustable in the interface. Properly adjust instrument gain settings between samples, and select whether to preview or record data with the appropriate acquisition criteria at selected sample flow rates.

Creating a new Loader experiment with Reference Group:

- 1 Select Edit in the Acquisition menu to edit the Plate experiment.

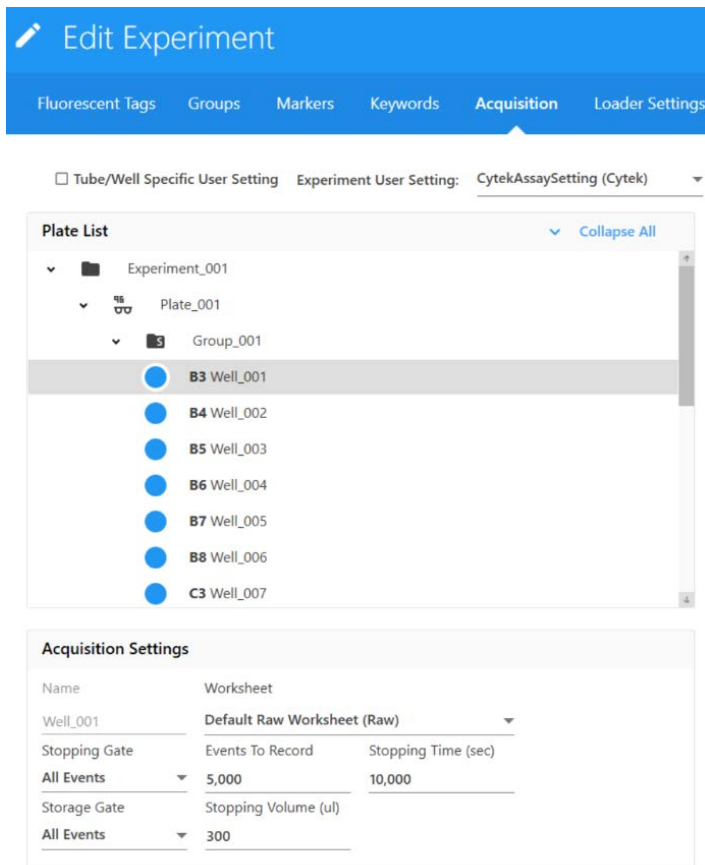

- 2 The new experiment wizard opens. In this window, the user can specify a name for the experiment and/or type in a description.

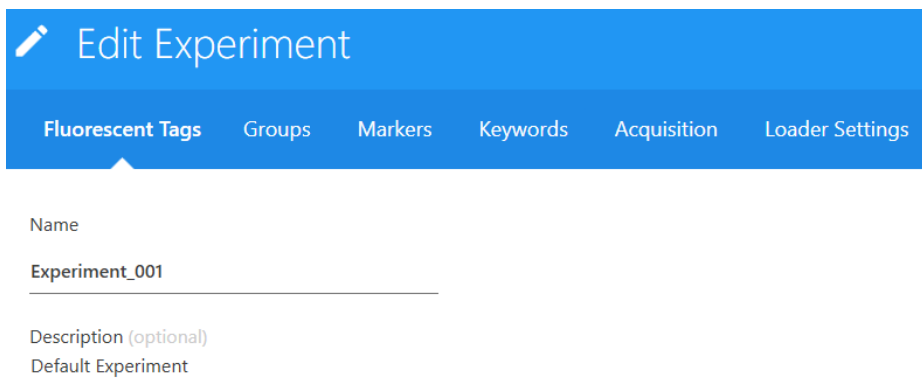

- 3 The user must then select the fluorophores that are present in the experiment from the Library list pane on the left. The user needs to select all individual fluorophores present in the experiment as this will determine which reference controls are to be used during spectral unmixing. Additional fluorophores that are not present in the sample can also be selected from this list.

- Library**
- ▼ Blue Laser
 - BB515
 - Alexa Fluor 488
 - FITC
 - Alexa Fluor 532
 - PE
 - PE-Dazzle594
 - PE-eFluor 610
 - PE-CF594
 - PE-Texas Red
 - PE-Alexa Fluor 610
 - PE-Cy5
 - PerCP
 - PE-Cy5.5
 - PerCP-Cy5.5
 - BB700
 - PerCP-eFluor 710
 - PE-Alexa Fluor 700
 - PE-Cy7
 - ▶ Red Laser
 - ▶ Violet Laser
 - ▶ Fluorescent Proteins
 - ▶ Viability

■ **NOTE:** You can search for fluorophores in the upper right corner of the Library pane.

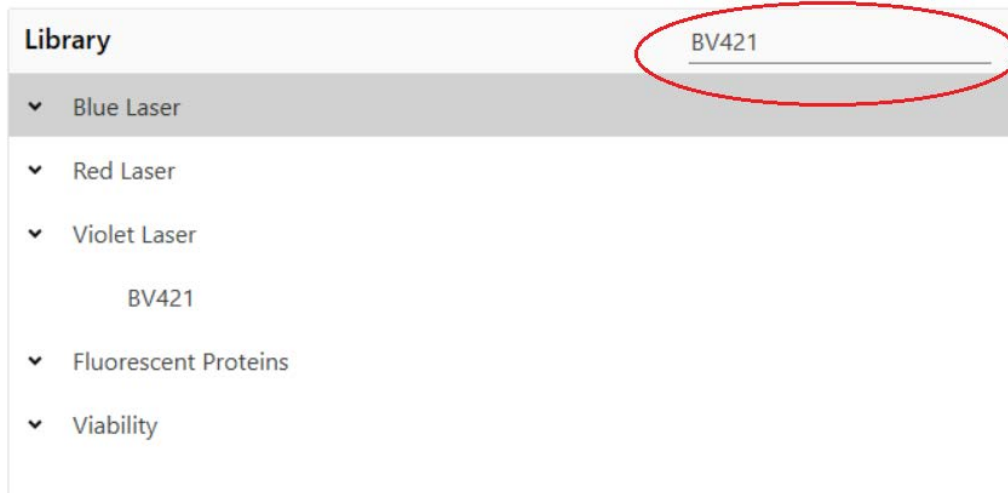

- 4 Once all fluorophores have been chosen from the fluorophore library, confirm in the selection pane. Individual fluorophores can be removed in this pane. Select Clear All to remove all fluorophores.

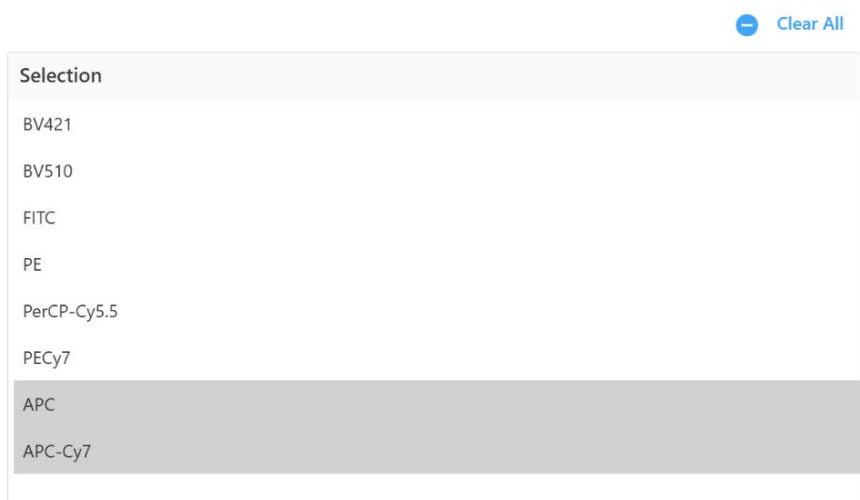

- 5 Select the wells on the plate to designate them for acquisition. Configure them as either a sample, reference, or clean well.

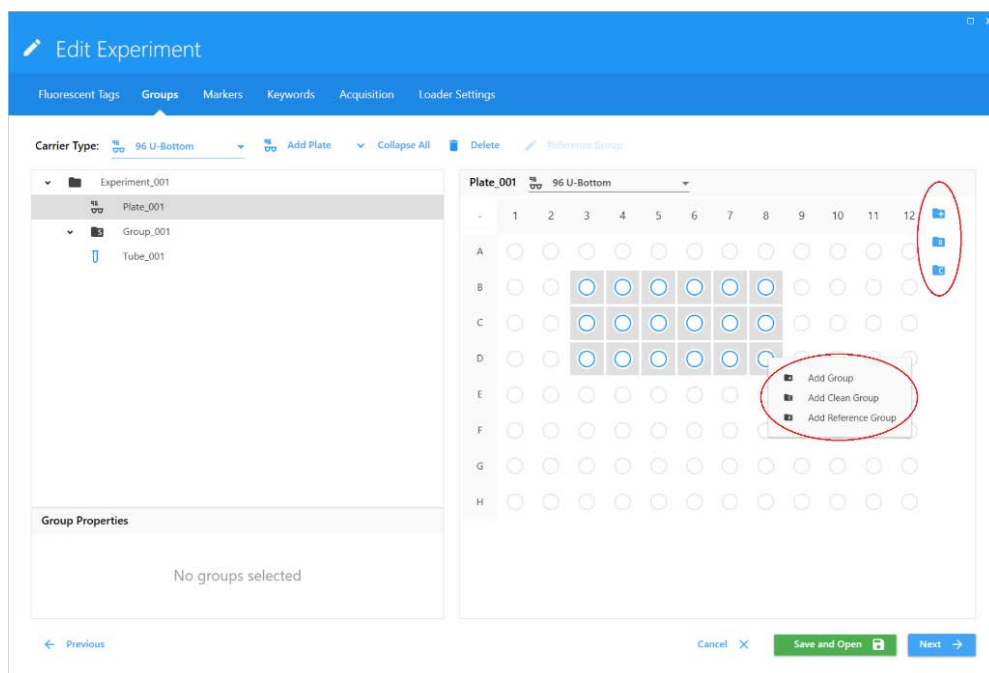

- 6 Using the Acquisition tab, configure the parameters of the experiment. These include display worksheet, stopping and storage gates, and acquisition criteria.

Edit Experiment

Fluorescent Tags Groups Markers Keywords **Acquisition** Loader Settings

Tube/Well Specific User Setting Experiment User Setting: **CytekAssaySetting (Cytek)**

Plate List ▼ Collapse All

- Experiment_001
 - Plate_001
 - Group_001
 - B3 Well_001**
 - B4 Well_002
 - B5 Well_003
 - B6 Well_004
 - B7 Well_005
 - B8 Well_006
 - C3 Well_007

Acquisition Settings

Name	Worksheet	
Experiment_001	Default Raw Worksheet (Raw) ▼	
Stopping Gate	Storage Gate	Stopping Time (sec)
All Events ▼	All Events ▼	10,000
Events To Record	Stopping Volume (ul)	Stopping Criteria
5,000	1 - 3000	<input type="checkbox"/> Count & Volume
User Setting		
CytekAssaySetting (Cytek) ▼		

Using the Loader settings tab, configure the operation parameters of the Loader. These include shake configuration, SIT Flush Times, Sample Recovery, and Record Data Delay Time.

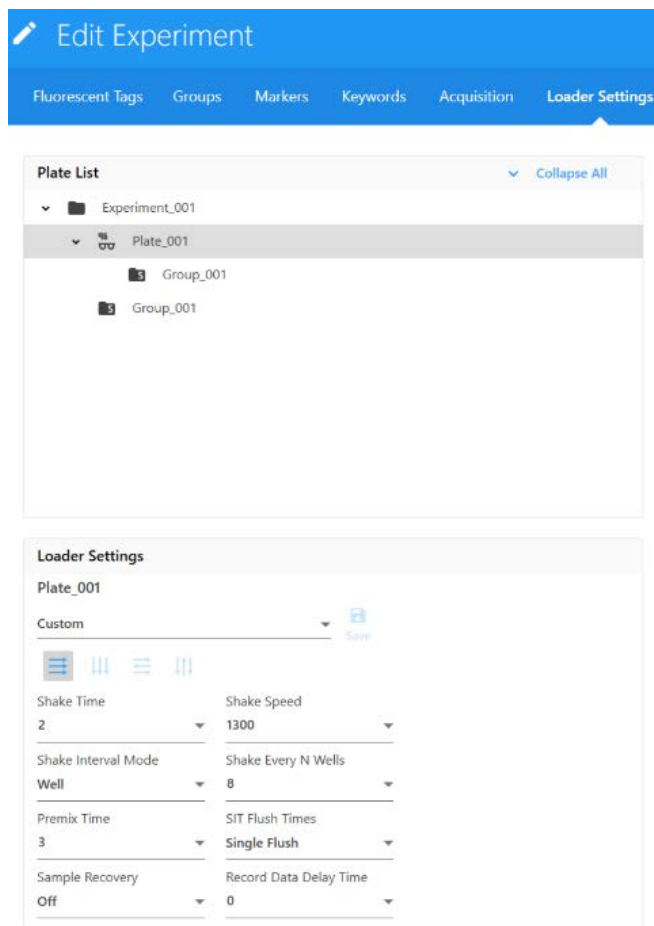

Loader Shutdown



Always adhere to proper handling procedures for samples and reagents. Wear standard PPE laboratory attire such as protective gloves, eyewear, and lab coat during this procedure.

Fluidics shutdown with loader tube rack:

- 1 In the Cytometer Wizard, select Fluidics Shutdown with Tube rack.
- 2 Load the 10% Bleach tube into the A1 position (Tube position can be changed by dragging on plate view).
- 3 Load the deionized water tube into B1 position (Tube position can be changed by dragging on plate view).
- 4 Load the 30% Contrad tube into C1 position (Tube position can be changed by dragging on plate view).
- 5 Load the deionized water tube into D1 position (Tube position can be changed by dragging on plate view).

- 6 Leave the SIT submerged underneath deionized water of the last tube.
- 7 Exit SpectroFlo software.
- 8 Turn off the cytometer and computer.
- 9 Turn off the Loader.

Maintenance

Maintenance Schedule



Any instrument surface in contact with biological specimens can transmit potentially fatal disease. Use universal precautions when cleaning the instrument or replacing parts. Wear suitable laboratory attire such as protective gloves, eyewear, and lab coat.

The 10% bleach solution used throughout the maintenance procedures is prepared by adding 1 part household bleach to 9 parts DI water.

Routine maintenance of the NL-CLC cytometer includes periodic replacement of parts. For part numbers, see [“Supplies and Replacement Parts” on page 157](#).

Scheduled Maintenance

The following table describes the scheduled maintenance procedures for your cytometer.

Maintenance Procedure	Description	Frequency
Replace sheath filter	Ensures debris-free sheath fluid	Every 6 months, or as needed
Long Clean	Cleans the fluidic lines with 10% bleach solution	Once a month and prior to service calls

Unscheduled Maintenance

The following table describes the unscheduled maintenance procedures for your cytometer.

Maintenance Procedure	Description	Frequency
SIT Flush	Backflushes the SIT	As needed, if SIT clogs or after running sticky dyes
Purge Filter	Removes bubbles from the sheath filter	If bubbles are present in the sheath filter, or if the plenum or sheath tank runs dry
Clean Flow Cell	Runs 10% bleach solution followed by DI water through the flow cell	As needed, or after running sticky dyes
Clean external surfaces	Keeps surfaces free from salt buildup	As needed

SIT Flush

A sample line backflush is performed whenever a tube is removed from the SIP after sample acquisition. If the sample line exhibits signs of carryover or becomes clogged after completing an experiment with a sticky dye such as propidium iodide, acridine orange, or thiazole orange, the sample line should be manually backflushed.

- 1 In the Cytometer tab, from either the QC & Setup or Acquisition module, select SIT Flush.

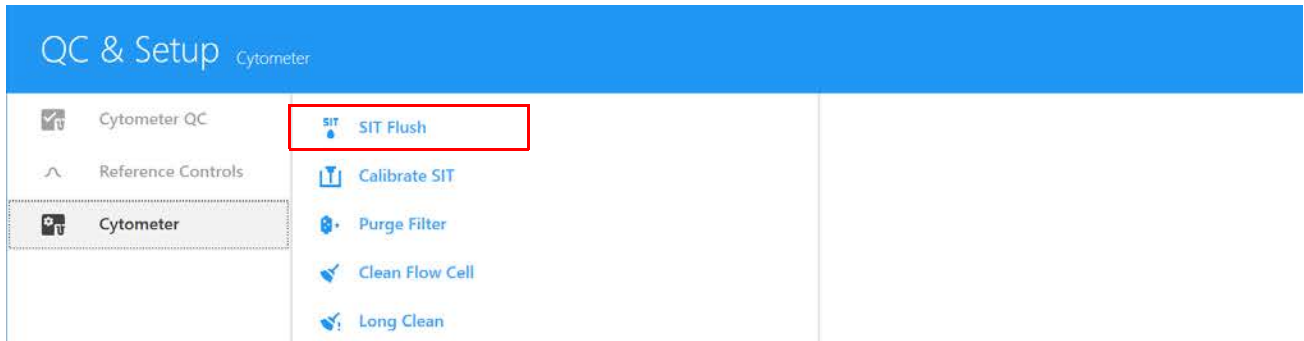

- 2 If carryover or a clog persists, place a tube of 10% bleach on the SIP and acquire at High flow rate for 5 minutes. Afterwards, acquire a tube of DI water at High flow rate for 5 minutes.

■ **NOTE:** If running large quantities of beads or large cells, we recommend running a tube of 10% bleach followed by a tube of DI water, each for 5 minutes, between experiments.

Purge Filter



Perform this procedure if air bubbles are visible in the sheath filter, or if the plenum or sheath tank have run dry and air is present in the fluidics system.

- 1 In the Cytometer tab, from either the QC & Setup or Acquisition module, select Purge Filter.

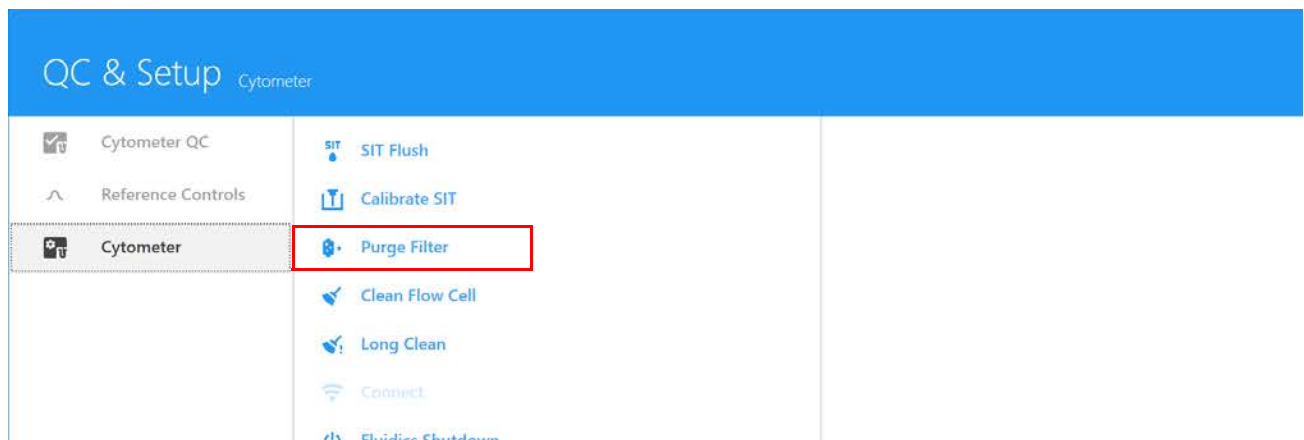

The vent valve connected to the sheath filter will open releasing any air bubbles trapped inside the sheath filter.

- 2 Repeat the Purge Filter fluidic mode until there are no visible bubbles inside the sheath filter.

Clean Flow Cell

Clean the flow cell after completing an experiment with a sticky dye such as propidium iodide, acridine orange, or thiazole orange. Cleaning the flow cell is also recommended after acquiring large quantities of highly concentrated bead solutions or if you suspect a clog.

If running sticky samples, perform this procedure using a 50% Contrad 70 solution instead of 10% bleach between experiments.

- 1 In the Cytometer tab, from either the QC & Setup or Acquisition module, select Clean Flow Cell.

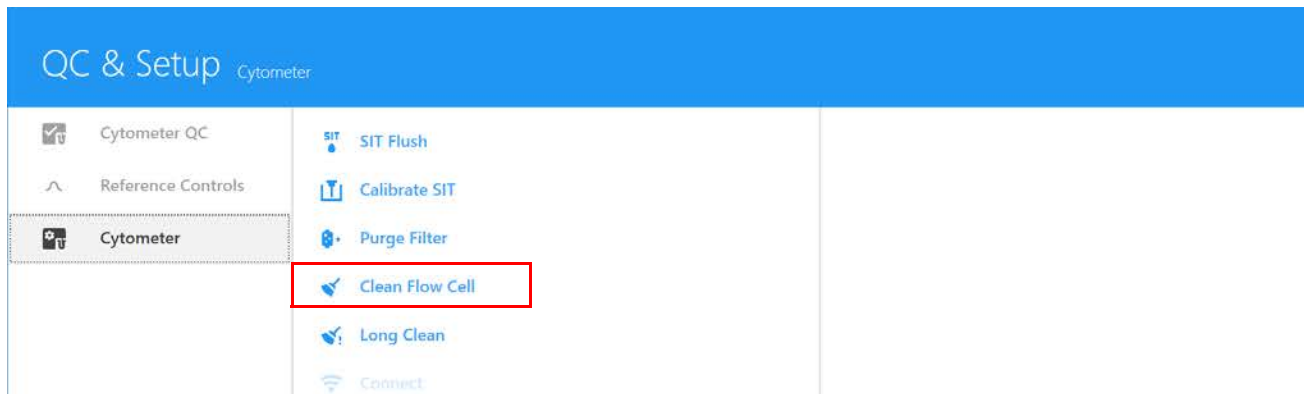

- 2 Follow the instructions that appear. Load a tube containing 3 mL of 10% bleach solution on the SIP and click Continue.
- 3 When prompted, load a tube containing 3 mL of DI water on the SIP and click Continue.
- 4 Click Done when the procedure is complete.

Long Clean

Decontaminate the fluidics system monthly by running the Long Clean fluidics mode. Run the Long Clean just prior to service calls, or if you run high volumes of unwashed samples or samples stained with propidium iodide, acridine orange, or thiazole orange.



Do not run bleach or detergent through the sheath filter. It is difficult to remove cleaning solutions from the sheath filter.

- 1 In the Cytometer tab, from either the QC & Setup or Acquisition module, select Long Clean.

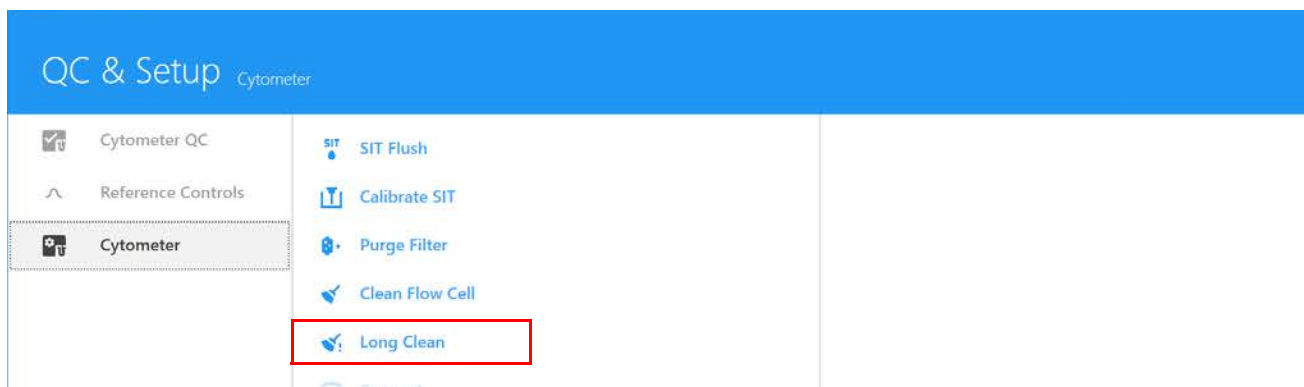

- 2 Follow the instructions that appear. Prepare the appropriate cleaning tubes and fluidics tanks.
- 3 Empty the waste tank. Replace the sheath filter with the sheath filter bypass (long clean tubing) assembly.



- 4 Detach the sheath tank and replace it with a tank containing a 10% bleach solution.
- 5 Load a tube containing 3 mL of a 10% bleach solution on the SIP.
- 6 Proceed with the Long Clean in the software.
- 7 Once the bleach cleaning cycle is complete, reattach the sheath tank.
- 8 Remove the tube of 10% bleach from the SIP and replace with a tube of 3 mL of DI water.
- 9 Proceed with the Long Clean in the software.
- 10 When prompted, remove the long clean tubing assembly and re-install the sheath filter.

Fluidics Shutdown

Perform fluidic shutdown at the end of each day that you use the instrument. The shutdown procedure thoroughly cleans the fluidics system.

- 1 In the Cytometer menu from either the QC & Setup or Acquisition module, select Fluidics Shutdown.
- 2 Load a tube containing 3 mL of 10% bleach on the SIP and click Continue.
A 10% bleach solution is prepared by adding 1 part household bleach to 9 parts DI water.
- 3 Load a tube containing 3 mL of DI water and click Continue.
- 4 Load a tube containing 3 mL of 50% Contrad 70 and click Continue.
- 5 Load a tube containing 3 mL of DI water and click Continue.
- 6 Allow the shutdown procedure to complete, then click Done and turn off the cytometer. Make sure the SIT is submerged in the DI water at the end of the procedure.

The following day when you turn on the system, the startup procedure begins, using the tube of DI water on the SIP.

Cleaning the External Surfaces

Periodically check for saline residue.

- 1 Dampen a cloth with a mild cleaning solution and wipe the surfaces of the instrument.
- 2 Dampen a cloth with DI water and wipe the surfaces again to remove residual cleaning solution.
- 3 Dry the surfaces with a clean, dry cloth.

Inspecting the Fluidics Lines



Check the cytometer periodically for fluid leaks. If any evidence of a leak is detected, contact Cytek Technical Support immediately. Do not attempt to repair the instrument.

- 1 Visually inspect for fluid leaks by looking for small pools of liquid near any of the quick-connects.
- 2 Visually inspect for dried residue or slight discoloration in the spaces surrounding the cytometer.

Replacing the Sheath Filter

The sheath filter traps debris and air bubbles before they reach the flow cell. Replace the filter assembly every 6 months, or when you see increased sample flow rates or debris in an FSC vs SSC plot.



Wear appropriate safety attire such as protective gloves, eyewear, and lab coat while performing this procedure.

- 1 Turn off the cytometer.
- 2 Open the front cytometer panel.

- 3 Press the two fluidics line quick-connects and the vent line quick-connect to the right of the sheath filter.

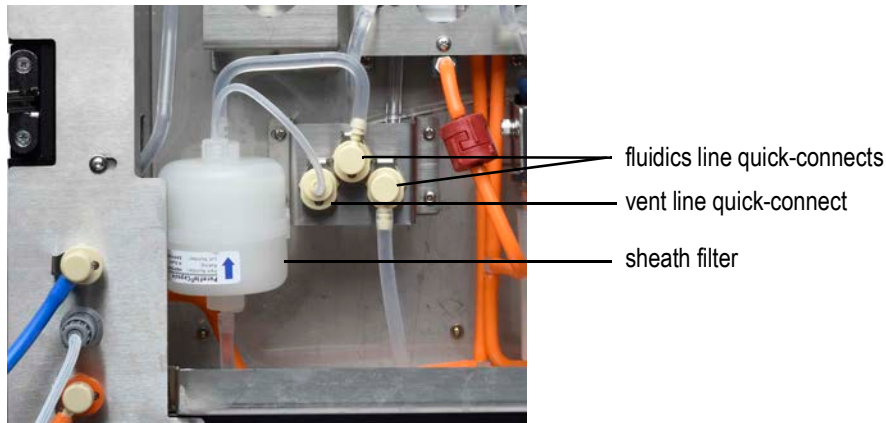

- 4 Discard the sheath filter according to standard laboratory protocol and local regulations.
- 5 Install a new sheath filter with the arrow pointing up.
- 6 Restart the cytometer and run the Purge Filter fluidic mode to remove air bubbles (see [“Purge Filter” on page 132](#)). Repeat this step until all air bubbles are purged from the filter.
- 7 Close the front panel.

Replacing the SIT

Replace the SIT if the tubing is clogged even after repeatedly cleaning and flushing the SIT.

- 1 Ensure the SIT is extended in a tube of DI water and the cytometer is turned off.

If the cytometer was shut down properly using the Fluidics Shutdown procedure, the SIT will already be extended and left in water.

■ **NOTE:** If the SIT is not extended, turn on the cytometer and run Fluidics Shutdown. Then turn off the cytometer.

- 2 Obtain a SIT tubing assembly.

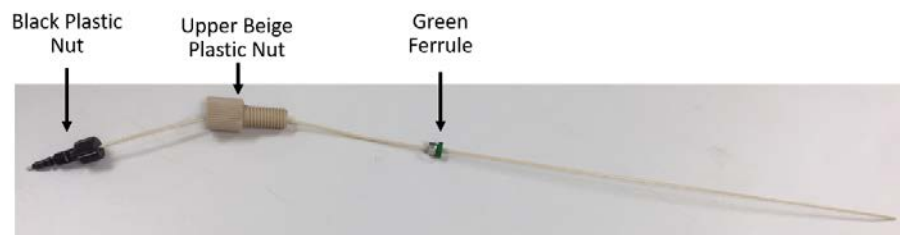

- 3 Open the SIT door. Identify the three components shown in the following figure.

Open the front panel, then open the SIT door. The SIT door is located above the SIP. See “[Front of Cytometer](#)” on page 12.

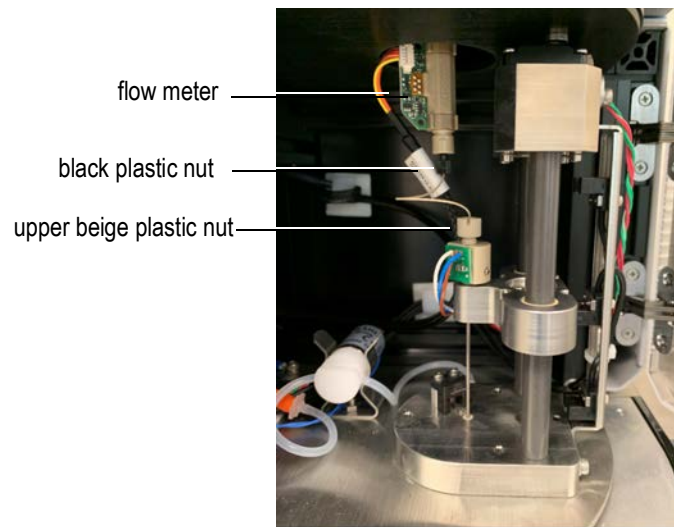

- 4 Twist off and carefully remove the black plastic nut from the bottom of the flow meter.



- 5 Follow the tubing from the black nut down to the beige plastic nut. Twist off the beige nut and gently pull it and tubing out from the SIP.



- 6 Discard the SIT tubing assembly.

7 Insert the new sample tubing through the hole.



8 Slide the beige nut down into the hole and turn the nut to secure, but do not tighten.

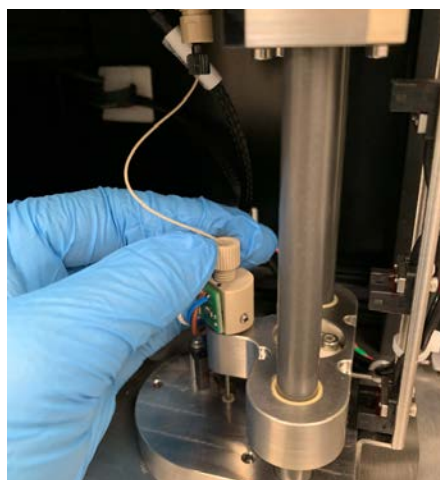

9 Mark the fully screwed in position at the base and on the nut, as shown. Then unscrew the nut 1½ revolutions from the marked position.



Mark position of screwed in nut.

10 Verify that the tubing contacts the bottom of the tube on the SIP.

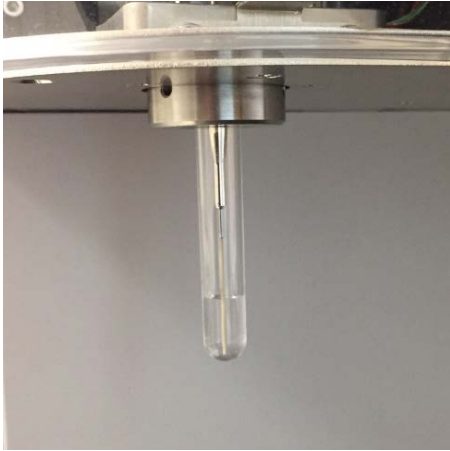

11 Secure the black nut to the bottom of the flow meter so it is firmly attached. Make sure the sample line bends away from the SIT assembly when the SIT stage rises.

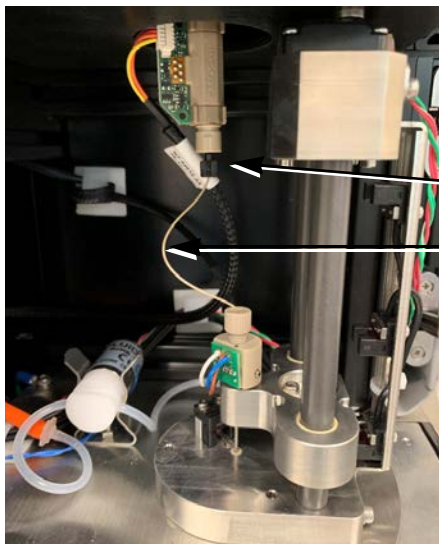

Secure black nut.

Ensure sample line bends away from SIT assembly.

12 Close the SIT door.

13 Turn on the system. During initialization the system automatically calibrates the SIT depth in the tube loaded on the SIP.

Loader Maintenance



Any instrument surface in contact with biological specimens can transmit potentially fatal disease. Use universal precautions when cleaning the instrument or replacing parts. Wear suitable laboratory attire such as protective gloves, eyewear, and lab coat.

Calibrating the Loader Stage and Plate

Click the Reset button to recalibrate the stage and plate if either of the following occurs:

- If the stage itself reaches the limit of its mechanical travel range.

- If any component that moves along with the stage reaches the limit of its mechanical travel range.

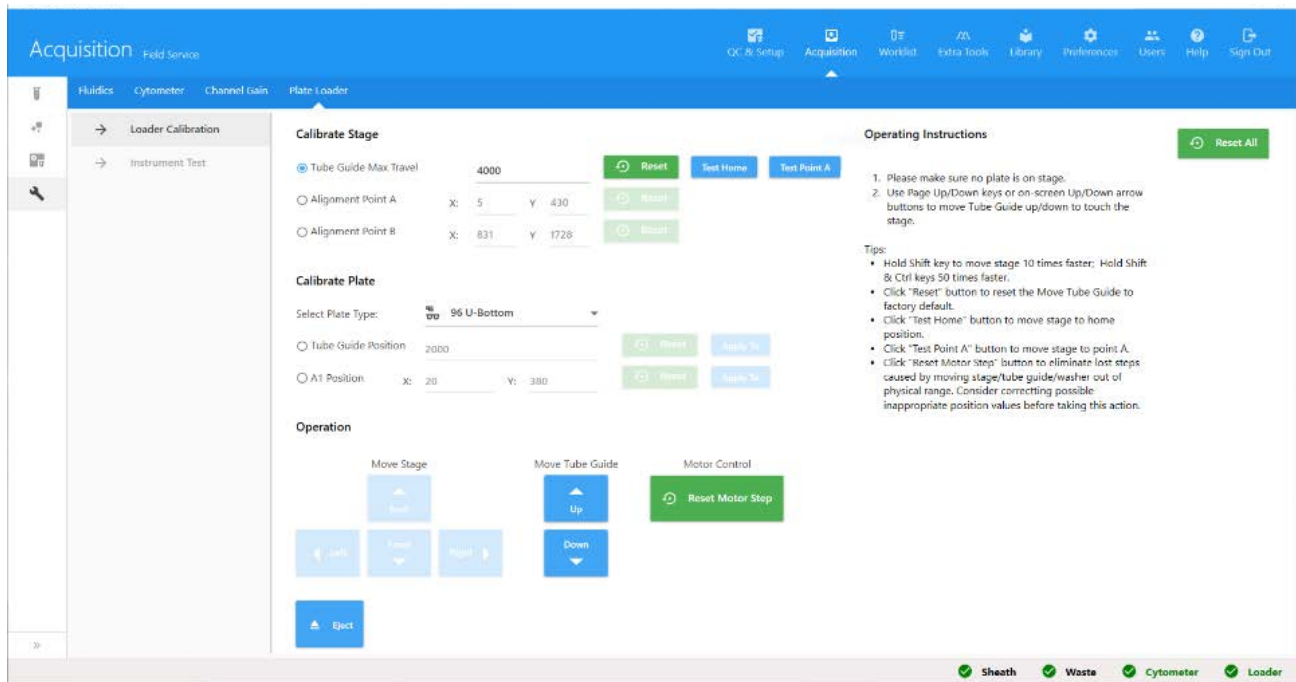

- 1 Pull the handle to the front. Observe the tube guide position and adjust the tube guide maximum travel to a suitable position.
- 2 Click Alignment Point A or Alignment Point B. Align the tube guide with the cross-shaped marker of the stage calibration fixture in the left/right and back/forth positions.
- 3 Place a standard well plate or deep well plate onto the shaker stage. Calibrate tube guide position and A1 position.
- 4 Pull the handle back and place the tube rack onto the shaker stage. Calibrate A1 position.

Cleaning the External Surfaces of the Loader

Periodically check for saline residue.

- 1 Dampen a cloth with cleaning solution and wipe dried sheath fluid from surfaces.
- 2 Wet a clean cloth with DI water and wipe surfaces to prevent bleach corrosion.
- 3 Wipe surfaces with a clean, dry cloth.

■ **NOTE:** High concentrations of sodium hypochlorite (bleach) and other cleaning agents can damage the instrument.

Loader Connections

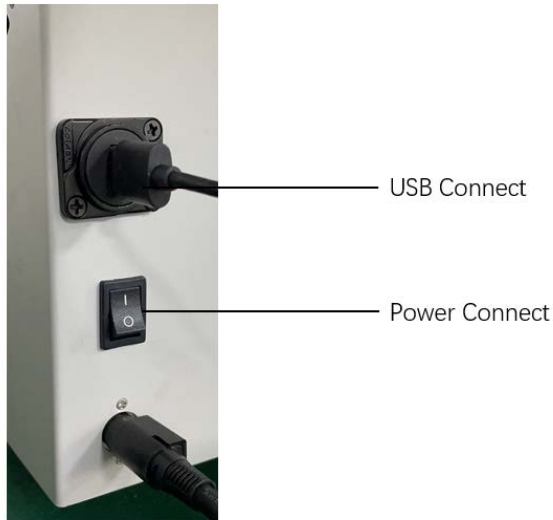

- USB2.0: Requires a standard USB2.0 type-A transfer USB2.0 type-A cable (approx. 1 meter length) for connection to computer.
- Power: Requires an IEC320-C8 power cable to connect with AC-DC power adapter.

Uninstalling the Loader Power supply

To uninstall the power supply:

- 1 Unplug the AC connection.
- 2 Unplug the Loader power supply connection.



Loader Lifting and Carrying Instructions

- Keep all equipment off the ground on a firm surface such as a table.
- Never place the Loader on the ground when in use.
- Use a cart or other stable support system to carry the Loader.

Troubleshooting

This section provides tips to help you identify and resolve issues that might occur on your flow cytometer. If additional assistance is required, contact Cytek Biosciences. Please have the following information available: serial number, error messages, and details of recent performance.

For instrument support within the US, call 1-877-92-CYTEK. Visit our website, www.cytekbio.com, for up-to-date contact information.

- [“General Troubleshooting” on page 144](#)
- [“Loader Troubleshooting” on page 146](#)

General Troubleshooting

Observation	Possible Causes	Recommended Solutions
Daily QC does not complete	Wrong QC bead sample	Ensure you are running SpectroFlo QC beads.
	Bead sample not properly mixed	Mix the bead sample.
	Bead sample too dilute	Concentrate the bead sample or prepare a fresh bead sample.
	Air bubble in sample line	Run a SIT Flush.
Daily QC failed	Air bubble in fluidics	Run a Purge Filter.
	Dirty flow cell	Run a Clean Flow Cell. If the problem persists, run a Clean Flow Cell using 25%–50% Contrad 70, followed by DI water.
	Questionable sample prep	Verify the sample prep technique.
	Air in sheath filter	Run a Purge Filter.
	Sample not diluted in same fluid as sheath	Dilute the sample in the same fluid as the sheath solution.
Air in sheath filter	Cytometer was not in use for a prolonged period	Run a Purge Filter. Check that all sheath connectors are securely attached. Check for leaks or cracks in the sheath plenum. Replace, if needed.
	Empty sheath tank	Fill the sheath tank. Run a Purge Filter.
No events displayed (flow rate lower than expected)	No sample in tube	Add sample or install a new sample tube.
	Sample not properly mixed	Mix the sample to suspend cells/particles.
	Clogged SIT	Run a SIT Flush. Then run a Clean Flow Cell with 10% bleach, followed by a Clean Flow Cell with DI water. If the clog persists, replace the sample line.

Observation	Possible Causes	Recommended Solutions
No events displayed (flow rate normal)	Insufficient gain for threshold parameter	Increase the gain for the threshold parameter.
	Threshold too high	Lower the threshold.
	Laser delay not correct	Ensure the laser delay values match those from the latest Daily QC run. See “Instrument Control” on page 46 for the laser delay location. If the values do not match, rerun Daily QC.
	Threshold set to incorrect parameter	Set the threshold to the appropriate parameter for the application (usually FSC).
	Gated plot with no data in gate	Delete or move the gate.
Low sample event rate	Threshold too high	Lower the threshold.
	Insufficient gain for threshold parameter	Increase the gain for the threshold parameter.
	Sample not properly mixed	Mix the sample to suspend cells/particles.
	Sample too dilute	Concentrate the sample. Set the flow rate to Medium or High.
	Clogged SIT	Run a SIT Flush. Then run a Clean Flow Cell with 10% bleach, followed by a Clean Flow Cell with DI water. If the clog persists, replace the sample line.
Erratic event rate	Partially blocked SIT	Run a SIT Flush. Then run a Clean Flow Cell with 10% bleach, followed by a Clean Flow Cell with DI water.
	Clumpy sample	Vortex, filter, or disaggregate the sample.
Data in scatter parameters appear distorted	Air bubble in flow cell	Run a SIT Flush.
	Air in sheath filter	Run a Purge Filter.
	Dirty flow cell	Run a Clean Flow Cell.
	Poor sample health	Check the viability of the cells.
	Hypertonic buffers	Check the pH of the buffers and fixative.
	Incorrect instrument settings	Optimize the instrument settings.

Observation	Possible Causes	Recommended Solutions
High CVs	Air bubble in fluidics	Run a SIT Flush and a Purge Filter.
	Sample flow rate set to High	Set the sample flow rate to Low or Medium.
	Dirty flow cell	Run a Clean Flow Cell. If the problem persists, run a Clean Flow Cell using 25%–50% Contrad 70, followed by DI water.
	Questionable sample prep	Verify the sample prep technique.
	Air in sheath filter	Run a Purge Filter.
	Sample not diluted in same fluid as sheath	Dilute the sample in the same fluid as the sheath solution.

Loader Troubleshooting

Observation	Possible Causes	Recommended Solution
Stage or motor not moving	USB connection	Check that the USB cable and USB connector are not loose.
	Power connection	- Check that the Adapter power, AC-DC power cable, and DC-DC power cable have good connections. - Use a meter to check if the DC output of the adapter power is 24VDC.
	Mechanical breakdown	With power switch OFF, manually push and pull the stage to check if the motion is smooth.
Stage is not aligned	Stage calibration is not correct.	- Re-calibrate the instrument by following the calibration steps in software. - Check if there is significant skew on the stage. - Check if the software configuration for Plate/Deep Well/Tube Rack is correct.

Glossary

ASL	Automated Sample Loader mixes samples and delivers tube racks and plates to the cytometer for acquisition.
APD	Avalanche photodiode (APD) is a highly sensitive semiconductor electronic device for measuring light intensity. APDs convert light to electricity and can be thought of as photodetectors.
auto-fluorescence	The inherent fluorescence arising primarily from cell structures such as mitochondria and lysosomes. Auto-fluorescence can hinder detection of dim fluorescent signals.
compensation	The process by which spillover fluorescence from secondary parameters is accounted for so that fluorescence values for a parameter represent only the fluorescence of the primary fluorophore.
data file	A collection of measured values from a single sample combined with text describing the data that has been stored as a flow cytometry standard (.fcs) file to disk.
deconvolve	An algorithm-based process used to reverse the effects of convolution (or overlapping) on recorded data.
detector	A device that responds to a specific stimulus. Photodiodes and APDs tubes are two types of detectors in cytometers. They convert light signals into electronic signals.
dot plot	A graphical representation of two-parameter data. Each axis of a plot displays values of one parameter.
electronic noise	Random fluctuation in electronic signals, a characteristic of all electronic circuits.
event rate	The rate at which cells or particles are acquired.

FCS	Flow cytometry standard, a standard format for flow cytometry data files.
filter	An optical device that blocks the passage of part of the incident light, allowing the rest to pass virtually unchanged.
flow cell	The flow cell enables hydrodynamic focusing of the sample so that the individual cells or particles of interest can be interrogated by the laser(s) sequentially.
flow cytometry	A technology that simultaneously measures and analyzes multiple characteristics of single cells or particles as they pass through a laser beam.
flow rate	The amount of fluid passing through a point per unit of time. The NL-CLC cytometer's flow rate is measured by the flow meter.
fluorescence	The emission of light of longer wavelengths that occurs when a substance absorbs light of shorter wavelengths.
fluorophore	A fluorescent dye. A molecule capable of absorbing light energy, then emitting light at a longer wavelength (fluorescence) as it releases this energy.
gain	Amplification of a signal. Increasing gain results in a larger output signal for a given input signal.
gate	A numerical or graphical boundary (region) that defines a subset of data. Gates can be single- or multi-dimensional.
laser	Light Amplification by Stimulated Emission of Radiation. A light source that is highly directional, monochromatic, coherent, and bright. The emitted light is in one or more narrow spectral bands, and with most lasers, is concentrated in an intense, narrow beam.
laser delay	Amount of time between signals from different laser intercepts.
photodiode	A device for measuring light intensity. A photodiode generates an output current proportional to the incident light intensity.
rCV	Percent robust coefficient of variation. The robust CV is a measure of dispersion of a probability distribution or a frequency distribution.

rSD	Robust standard deviation. The robust SD is based on the deviation of individual data points to the median of the population.
reference	Spectral profile of a fluorescent tag in all detectors for all lasers.
resolution	A measure of a cytometer's ability to distinguish between two populations with differing fluorescence or light scatter intensities.
sensitivity	A measure of a cytometer's ability to distinguish particles from background noise. It is often expressed in terms of a minimum number of fluorescent molecules per particle required to distinguish a stained particle from an unstained particle. Sensitivity depends on the instrument, the dye, and the preparation method.
SIP	Sample injection port. The area of the cytometer where the sample is placed.
SIT	Sample injection tube. The probe that pulls sample from the sample tube to the flow cell.
spectral overlap	The phenomenon of different fluorophores emitting light within the same detection range. In multi-color experiments, compensation must be performed to correct for spectral overlap.
spectral unmixing	The mathematical method of deconvolving signals from multiple fluorophores/dyes to differentiate them.
spillover	Emitted light from a fluorophore entering the detector of another fluorophore.
voltage	Measure of electric potential. The voltage applied to a detector affects its amplification gain.

Specifications

Cytometer

Optics

Item	Specification
Optical platform	Fixed optical assembly configured with up to three spatially separated laser beams. Laser delays are automatically adjusted during instrument QC.
Lasers	405 nm: 100 mW (violet) 488 nm: 50 mW (blue) 640 nm: 80 mW (red)
Beam geometry	Flat-top laser beam profile with narrow vertical beam height optimized for small particle detection.
Emission collection	Fused silica cuvette coupled to high NA lens for optimum collection efficiency to optical fibers.
Forward scatter detector and filter	High-performance semiconductor detector with 488-nm bandpass filter.
Side scatter detectors and filters	Two high-performance semiconductor detectors with 405- and 408-nm bandpass filters.
Fluorescence detectors	High-sensitivity Coarse Wavelength Division Multiplexing (CWDM), 16-channel semiconductor detector array per laser, enabling more efficient spectrum capture for dyes emitting in the 420-nm to 830-nm range. No filter changes required for any fluorophore excited by the on-board lasers. NOTE: See the table on page 104 for the detector bandwidth specifications.

Fluidics

Item	Specification
General operation	Vacuum driven fluidics with the following fluidics modes: Long Clean, SIT Flush, Purge Filter, Clean Flow Cell, Fluidics Shutdown.
Compatible tubes	12 x 75-mm polystyrene and polypropylene tubes
Fluidic reservoirs	4-L fluid tanks with level-sensing provided. Compatible with 20-L sheath and waste cubitainers.
Sample flow rates	Three preset flow rates measured by the flow meter: Tube mode: <ul style="list-style-type: none"> • Low: 15 μL/min • Medium: 30 μL/min • High: 60 μL/min
Data acquisition rate	Up to 35,000 events/s (for three-laser systems)

Performance

Characteristic	Parameter	Acceptance Criteria	Result
Analytical sensitivity	Fluorescence Sensitivity	Minimum sensitivity: FITC \leq 200 MESF PE \leq 100 MESF. APC \leq 15 MESF Pacific blue \leq 190 MESF	MESF Results: FITC = 51 PE = 51 APC = 14 Pacific Blue = 13
	Fluorescence Linearity	$R \geq 0.98$	$R > 0.99$ for all
	Forward Scatter (FSC) Sensitivity	Forward scatter to distinguish 1 μ m microparticle from debris by relative size	0.98 μ m beads were separated from debris by FSC
	DNA Ploidy test Linearity	G2/M to G0/G1 MFI ratio shall be between 1.95 to 2.05.	G2/M to G0/G1 ratio = 2.03
Scatter resolution	FSC/SSC Resolution	FSC \leq 3.0 %CV SSC \leq 8.0 %CV	FSC 2.96 %CV SSC 4.55 %CV
Accuracy	Accuracy of Cell Surface Marker Detection	Using CD-Chex Plus (Streck, Cat# 213365) sample for cell surface markers, CD3, CD4, CD8, CD16/56, and CD19, the positive cells as percentages of lymphocytes should be within product insert target range provided by vendor	The cell populations tested, CD3+, CD3+CD4+, CD3+CD8+, CD3-CD19+ and CD3-(CD16+CD56+) as percentages of lymphocytes are within the published target ranges. Data on file.

Characteristic	Parameter	Acceptance Criteria	Result
Precision (Repeatability & Reproducibility)	Repeatability of Cell Surface Marker Detection	<p>Repeated measurement of specimens across multiple instruments with cell surface markers, CD3, CD4, CD8, CD16/56, and CD19, %CV of positive cell percentages shall meet the following criteria:</p> <p>If positive cell percentages $\geq 30\%$, the %CV shall be $\leq 8\%$.</p> <p>If the positive cell percentages $< 30\%$, the %CV shall be $\leq 15\%$</p>	The %CV for each cell population measured in 10 repeated tests are less than 6% and meet the acceptance criteria. Data on file.
Assay workflow validation	Carryover Instrument Reliability	Carryover shall be $\leq 0.5\%$	Carryover $< 0.003\%$
		When environmental temperature remains within 5% of the design operating temperature, within any 8-hour period, there shall be no variation greater than $\pm 10\%$ in intensity of FSC and any fluorescence channel	The testing results demonstrate that the variation of MFI in any channel was less than $\pm 10\%$. Data on file.

Workstation

Item	Specification
Operating system	Microsoft® Windows® 10 Pro, 64-bit
Processor	Intel® Core™ i7 processor, 3.6 GHz
RAM	32 GB
Hard drive	500 GB SSD/1TB SATA
Video processor	530 NVIDIA® GeForce
Monitor	32-in UHD 4K Monitor

Loader Technical Specifications

General Specifications	
Plate Types	1 ml deep well plate, 2ml deep well plate, V bottomed standard 96 well plate, U bottomed standard 96 well plate, Flat bottomed standard 96 well plate
Tube Rack	40-Tube Rack
Computer Interface	USB 2.0
Mixing	Based on specific carrier in software configured with recommended shaking speed, shaking time, and shaking frequency.
Installation Requirements	
Dimensions	23 x 47 x 28 cm (9.1 x 18.5 x 11 in)
Weight	15 kg (33 lbs)
Recommended workspace	65 x 30 x 30 cm (26 x 12 x 12 in)
Adapter Power	Input: 110-240V~, 50/60 Hz, 2.0-1.0A Output: DC24V, 6.67A, 160W Max
Humidity	20% to 85% relative non-condensing
Environmental conditions	Altitude up to 2000 m (6560 ft), Pollution degree: 2
Air filtering	No excessive dust or smoke
Lighting	No special requirements

Installation Requirements

Item	Specification
Dimensions (W x D x H)	54 x 52 x 52 cm (21.3 x 20.5 x 20.5 in)
Weight	61 kg (134.5 lb) to 71 kg (156.5 lb)

Item	Specification
Workstation	3.5 x 18.3 x 17.9 cm (1.4 x 7.2 x 7.0 in)
Recommended workspace	152.4 x 61 x 132 cm (60 x 24 x 52 in)
Power	110/240 V~, 50/60 Hz, 3.5 A/1.5 A
Fuse rating	250 VAC, 5 A, size 5 x 20-mm
Heat dissipation	500 W with all solid-state lasers
Temperature	15°C–28°C
Environmental conditions	Indoor use
Altitude	Up to 2,000 m (6,562 ft)
Pollution degree	2
Humidity	20% to 85% relative non-condensing
Air filtering	No excessive dust or smoke
Lighting	No special requirements

Supplies and Replacement Parts

Item	Part Number	Description
4-L Tank	N4-00124	Fluidics bottle for sheath and waste
4L Supply Cap Assy	N7-32015	Lid for 4L sheath tank with tubing
4L Waste cap Assy	N7-32014	Lid for 4L waste tank with tubing and liquid level sensor
20L Cubitainer Adapter Assy	N7-32016	Tubing and caps to fit 20L waste and sheath containers
Reservoir Holder Assy	N7-32019	Holder for 4L sheath and waste tanks
SpectroFlo QC Beads 2000 Series, 2mL	B7-10001	Daily QC beads to validate instrument performance
Sheath filter assembly (0.2 μm)	N7-22006	0.2- μm sheath filter assembly with quick-connect fittings and manifold
Sheath filter assembly (0.4 μm)	N7-22016	0.4- μm sheath filter assembly with quick-connect fittings and manifold
Sample line	N7-22014	SIT tubing assembly
Sheath filter bypass (Long Clean tubing)	N7-22010	Replaces the sheath filter during a Long Clean
25-mm disk filter (20 μm)	N4-00047	Filter at sheath tubing intake for cubitainer and 4-L sheath tank cap

Index

A

accumulator vessel 14, 15

acquisition

- controls 45
- experiments 44
- preferences 71

adding

- fluorescent tags to library 64
- labels 65
- new user account 82

alarm ranges 41

Analyzing Data Offline 97

area scaling factor 47

B

benchmark reference controls 39

C

cleaning

- external surfaces 135
- flow cell 133
- SIT 132

cytometer

- cleaning surfaces 135
- fluid containers 14, 25–26
- fluidics system components 14–15
- lasers 16
- optics 15
- overview 12
- power button 12
- replacement parts 157
- sheath filter 15
- shutdown 28
- SIT/SIP 13

D

daily QC

- performing 29–32
- report 32

data

- formats 43
- raw 43, 97
- unmixed 43, 97, 98, 101

degasser 14

deleting

- user account 83

E

editing

- fluorescent tag properties 64
- gate properties 50
- plot properties 49
- user account 83

experiment

- about 18
- creating new 54–60
- default 18, 22
- display 44–51
- exporting 19
- setup overview 44
- templates 19, 69
- toolbar 48

export

- experiment 19
- QC report 32

F

FCS files

- formats 19, 43
- raw data 97
- storage preferences 78
- unmixed data 97, 98, 101

flow cell, cleaning 133

flow meter 137

fluid containers 14, 25–26

fluidics lines

- inspecting 135

fluidics system

- components 14–15
- decontaminating 133
- specifications 152

fluorescent tag

- adding new 64
- editing properties 64
- groups 34
- library 63
- live unmixing 93

- running reference controls 34
- selecting in experiment 54

font preferences 77

G

gain

- adjusting 47
- See also* user settings
- settings 41

gates

- adjusting, post-acquisition unmixing 97, 101
- editing properties 50
- preferences 75

I

installation requirements 154

K

keywords 65

L

labels

- adding 65
- library 64

lasers

- detectors 16
- scaling factor 47

Levey-Jennings

- tab for performance tracking 29
- tracking 40

library

- experiment templates 69
- fluorescent tags 63
- keywords 65
- labels 64
- loader settings 68
- QC beads 63
- user settings 67
- worksheet templates 68

loader

- calibrating the loader Stage and plate 139
- connections 141
- daily workflow 123
- lifting and carrying instructions 141
- maintenance 139
- set up experiment 124
- settings 68
- settings and controls 122
- shut down 129
- startup 123
- troubleshooting 146

- uninstalling power 141

long clean 133

M

maintenance

- scheduled 131
- unscheduled 131

modules, software 17

N

notification preferences 78

O

optics 15

- compartment 12
- specifications 151

overview

- cytometer 12
- Northern Lights system 11
- software 17
- unmixing 90

P

password, resetting 83

plenum 14

plots

- preferences 74
- types and properties 48

post-acquisition unmixing

- in acquisition module 97–98
- in analysis module 98, 99–101

power button 12

preferences

- acquisition 71
- fonts 77
- gates 75
- notifications 78
- plot 74
- QC setup 80
- statistics 76
- storage 78
- worksheet 73

Q

QC beads

- library 63
- running 29–32

QC reports

- exporting 32
- pass/fail criteria 32

QC setup
 preferences 80

R

reference controls 34
 comparing to benchmarks 94
 running 34–38
 selecting benchmarks 39
 updating 39

replacement parts 157

replacing
 sheath filter 135
 SIT 136–139

S

safety
 biological 9
 electrical 9
 general information 8
 symbols 7

sample injection port (SIP) 13

sample injection tube (SIT) 13
 compartment 12
 flushing 132
 flushing, loader 123
 replacing 136–139

settings
 user 41

sheath container 14
 filling 25–??

sheath filter 15
 purging 132
 replacing 135

sheath plenum 14

shutdown procedure 28

shutting down system 28

signal measurements 47

SIP
 See sample injection port

SIT
 See sample injection tube

software
 FCS file formats 43
 modules 17
 overview 17

spillover 89
 adjusting 102

statistics
 creating 50
 preferences 76

system
 overview 11
 shutdown 28
 starting up 27

T

technical support information 10

threshold 47

toolbar, experiment 48

tracking
 Levey-Jennings 40

troubleshooting 143–146

U

unmixing 89
 label/lot specific 72
 live 92–97
 overview 90
 post-acquisition 97–101

user settings 41
 library 67

users
 adding new account 82
 editing account 83
 removing account 83
 resetting user password 83
 use time on system 84

V

virtual filters 102–106

W

waste container 14
 emptying 26

worklist
 add tasks 108
 arrange sample locations in a carrier 112
 create or open 107
 data collection 112
 export report 113
 lot specific reference controls 111
 reference controls 109
 unmix 110

worksheet
 about 21
 preferences 73
 selecting 48
 templates 68

workstation specifications 154



 Cytek Biosciences, Inc
47215 Lakeview Blvd.
Fremont, CA 94538, USA
1.877.922.9835 (option 1)

products@cytekbio.com
cytekbio.com

EC	REP
----	-----

Emergo Europe
Prinsessegracht 20
2514 AP The Hague
Netherlands